

# Self-operated Temperature Regulators



## Type 2040 Safety Temperature Monitor (STM)



*Fig. 1 · Type 2040 Safety Temperature Monitor*

## Mounting and Operating Instructions

**EB 2090 EN**

Edition October 2014



Contents	Page
1	<b>Design and principle of operation</b> . . . . . 4
2	<b>Installation</b> . . . . . 6
3	<b>Set point adjustment</b> . . . . . 6
3.1	New adjustment . . . . . 7
3.2	Set point adjuster with set point indication . . . . . 7
4	<b>Maintenance</b> . . . . . 8
5	<b>Service</b> . . . . . 8
6	<b>Dimensions</b> . . . . . 9
7	<b>Technical data</b> . . . . . 10
8	<b>Nameplate</b> . . . . . 11

## Definitions of the signal words used in these instructions

---

### **CAUTION!**

*Indicates a hazardous situation which, if not avoided, could result in minor or moderate injury.*

---

---

**Note!** *Indicates supplementary explanations, information and tips.*

---

---

### General safety instructions

- ▶ *The regulator may only be mounted, started up or operated by trained and experienced personnel familiar with the product. According to these mounting and operating instructions, trained personnel refers to individuals who are able to judge the work they are assigned to and recognize possible dangers due to their specialized training, their knowledge and experience as well as their knowledge of the relevant standards. All safety instructions and warnings in these mounting and operating instructions, particularly those concerning assembly, start-up and maintenance, must be observed.*
- ▶ *For appropriate operation, make sure that the regulator is only used in applications where the operating pressure and temperatures do not exceed the operating values based on the sizing data submitted in the order.*
- ▶ *Note that the manufacturer does not assume any responsibility for damage caused by external forces or any other external factors. Any hazards which could be caused in the regulator by the process medium or operating pressure are to be prevented by means of appropriate measures.*
- ▶ *The Type 2040 Safety Temperature Monitors do not have their own potential ignition source according to the ignition risk assessment stipulated in EN 13463-1: 2001, section 5.2, even in the rare incident of an operating fault. Therefore, they **do not** fall within the scope of Directive 94/9/EC.*
- ▶ *The regulator complies with the requirements of the European Pressure Equipment Directive 97/23/EC. The declaration of conformity issued for a valve bearing the CE marking includes information on the applied conformity assessment procedure. The declaration of conformity can be provided on request.*

---

### TÜV typetesting/EC type examination

*The Type 2040 Safety Temperature Monitors are typetested by TÜV (German technical surveillance association). The test mark is available on request.*

*An EC type examination according to Pressure Equipment Directive 97/23/EC, Module B has been performed on the Type 2040 Safety Temperature Monitor.*

---

## 1 Design and principle of operation

The Type 2040 Safety Temperature Monitor protects downstream plants against excessively low temperatures in applications involving the storage of cryogenic media as well as liquids, gases and vapors.

These safety temperature monitors close whenever the medium temperature falls below the adjusted temperature set point (limit) to prevent cold media entering the connected consumer plant.

The safety temperature monitor consists of the body (1) with integrated temperature sensor (6) and set point adjuster (3). It operates according to the liquid expansion principle.

The volume of the temperature-sensitive filling medium confined in the integrated temperature sensor (6) expands as the temperature rises and contracts again as the temperature falls. The valve is normally open. If the medium temperature falls below the adjusted set point (when the medium is too cold), the liquid inside the sensor contracts and the tubular

plug (5) is pushed by the positioning springs (4) against the soft-sealed seat (2). As the medium temperature drops, the plug moves in the closing direction, restricting the medium flow. If the medium temperature drops further, the valve is closed completely when the temperature reaches the adjusted set point.

The set point temperature and the throttling range in front of it can be adjusted within the set point range. The valve first opens again when the medium temperature has exceeded the adjusted set point by 2 K.

The temperature span between the adjusted set point temperature  $T_{\text{set point}}$  and the point at which the regulator starts to close is 17 K. The valve is fully open ( $K_V = 5$ ) at a medium temperature of  $>T_{\text{set point}} + 17 \text{ K}$ . At a medium temperature less than  $T_{\text{set point}} + 17 \text{ K}$  the medium flow is already throttled and the  $K_V$  coefficient gets smaller (Fig. 2).

If the sensor system is **defective**, the valve **closes** (fail-safe position).

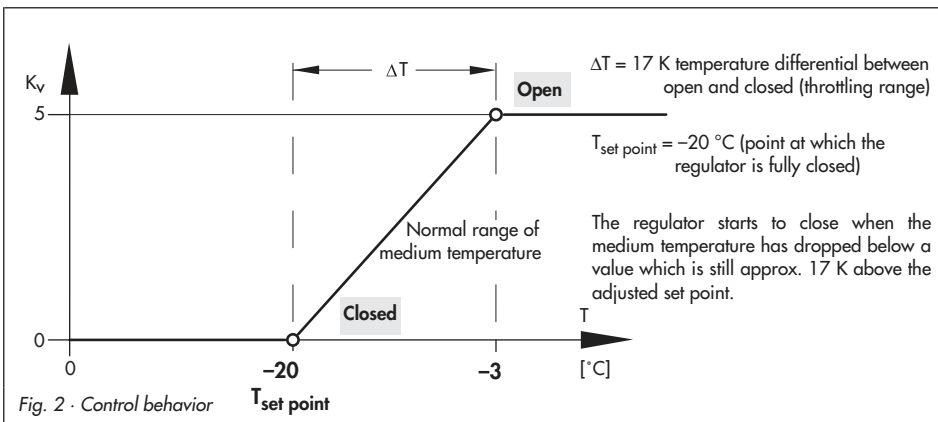
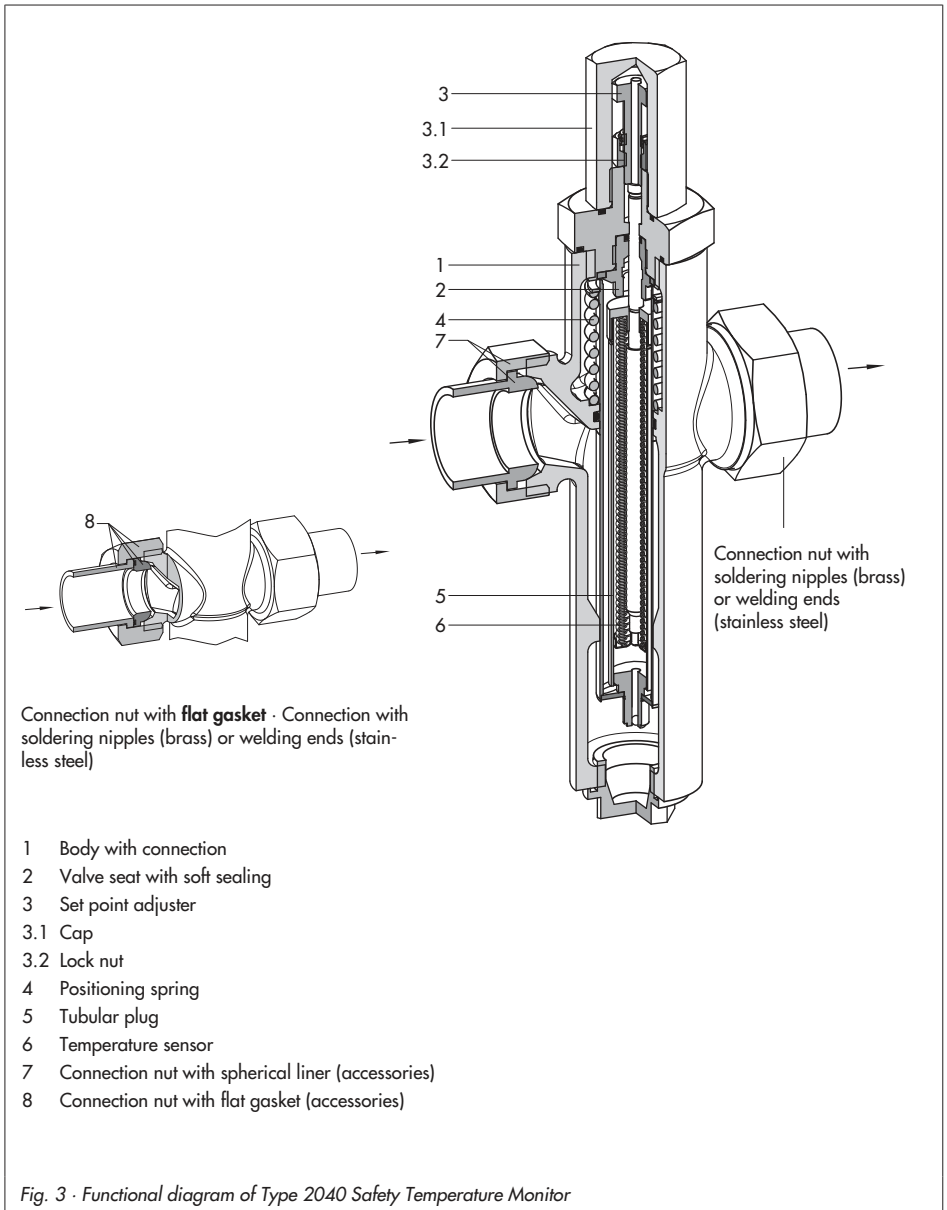

Fig. 2 · Control behavior



## 2 Installation

Connection fittings (accessories) must be provided at the site of installation.

### Note!

Do not install the regulator directly next to an air vaporizer. Otherwise, the regulator could close due to the low outdoor temperature. The closing function of the regulator does not depend on whether the sensor temperature is determined by the outdoor air or by the medium.

For outdoor installation, we recommend an adjusted set point temperature of  $-37\text{ }^{\circ}\text{C}$  together with the point at which the regulator is fully closed at  $-20\text{ }^{\circ}\text{C}$  (set point range  $-45$  to  $-10\text{ }^{\circ}\text{C}$ ).

The following points generally apply:

- ▶ The regulator can be installed in any desired position
- ▶ The direction of flow must match the arrow on the valve body

## 3 Set point adjustment

See Figs. 3 and 4

The safety temperature monitor has been adjusted by the manufacturer to a set point temperature (limit) of  $T_{\text{set point}} = -10\text{ }^{\circ}\text{C}$  (set point range from  $-30$  to  $+10\text{ }^{\circ}\text{C}$ ) or  $-37\text{ }^{\circ}\text{C}$  (set point range from  $-45$  to  $-10\text{ }^{\circ}\text{C}$ ).

After removing the cap (3.1) and undoing the lock nut (3.2), the required set point temperature ( $T_{\text{set point}}$ ) can be adjusted within the set point range using the set point adjuster (3).

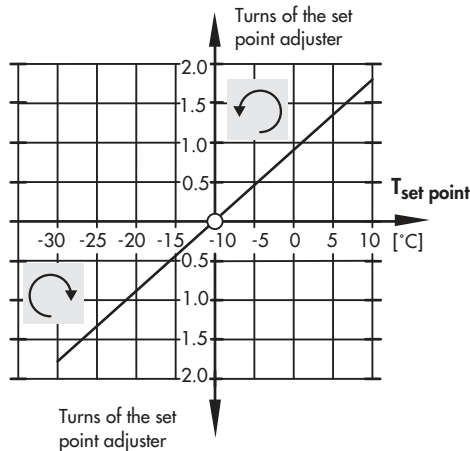

Fig. 4 · Adjustment diagram at a set point temperature  $T_{\text{set point}} = -10\text{ }^{\circ}\text{C}$  (point at which regulator is fully closed)

Use the adjustment diagram (Fig. 4) as a guide to change the set point temperature from the default setting. One turn of the set point adjuster corresponds to a change in set point temperature of approx. 13 K.

The set point temperature together with the point at which the regulator is fully closed shift to lower temperatures when the set point adjuster (3) is turned clockwise ☺.

### 3.1 New adjustment

Adjustment of the set point temperature from an unknown setting:

---

**Note!** *The ambient temperature must be within the set point range.*

---

- ▶ Remove cap (3.1) and undo lock nut (3.2). Make sure that the medium flow and outside air have the same temperature.
- ▶ Turn the set point adjuster (3) counter-clockwise until the flow noise inside the regulator ceases, i.e. the valve is closed.
- ▶ Calculate the temperature difference between the momentary ambient temperature and the required set point temperature ( $T_{\text{set point}}$ ) to be adjusted.
- ▶ Divide the calculated temperature difference by 13. The result shows how many turns of the set point adjuster (Fig. 4) are required.
- ▶ Turn the set point adjuster clockwise by the determined number of turns.
- ▶ Lock set point adjuster (3) with the lock nut (3.2) and screw cap (3.2) back on.

- ▶ Secure setting, if necessary, with sealing wire through the holes in the cap and valve.

### 3.2 Set point adjuster with set point indication

In a special version, the set point adjuster is fitted with a marked ring for set point indication. The distance between two marks corresponds to a temperature difference of approx. 10 K (10 °C).

## 4 Maintenance

---

### CAUTION!

*Prior to performing any work on the regulators, decommission the plant by slowly closing the shut-off valves. Depressurize and, depending on the process medium, drain the plant section as well.*

---

### CAUTION!

*Regulators for oxygen service are labeled to indicate that the regulators must be kept free of oil and grease for oxygen service.*



*These versions are cleaned and assembled under special conditions. Gloves must be worn when exchanging parts which come into contact to oxygen. These parts must not come into contact with oil or grease.*

*When returning regulators for oxygen service to SAMSON for repair, the sender is responsible for ensuring that the regulators are handled in conformance with the specifications in the German regulation VBG 62 or equivalent regulations until receipt at SAMSON. If this is not the case, SAMSON AG will not assume any responsibility for the suitability of these regulators for oxygen service.*

---

If the point at which the regulator closes deviates strongly from the adjusted set point, shut-off may be impaired because the seat and plug are clogged up with dirt or due to natural wear.

In this case, remove the regulator from the pipeline and clean it. If necessary, replace the plug seal with a new one.

## 5 Service

If malfunctions or defects occur, contact the SAMSON After-sales Service for support.

The addresses of SAMSON AG, its subsidiaries, representatives and service facilities worldwide can be found on the Internet at [www.samson.de](http://www.samson.de), in a SAMSON product catalog or on the back of these mounting and operating instructions.

Include the following details when making inquiries:

- ▶ Type and nominal size of the regulator
- ▶ Process medium
- ▶ Set point temperature range
- ▶ Production number 3- ...
- ▶ Model number with modification index
- ▶ Flow rate in m<sup>3</sup>/h
- ▶ Installation drawing indicating the exact location of the regulator (e.g. outdoors or indoors) and all additionally mounted units (shut-off valves, pressure gauges etc.)



## 6 Dimensions

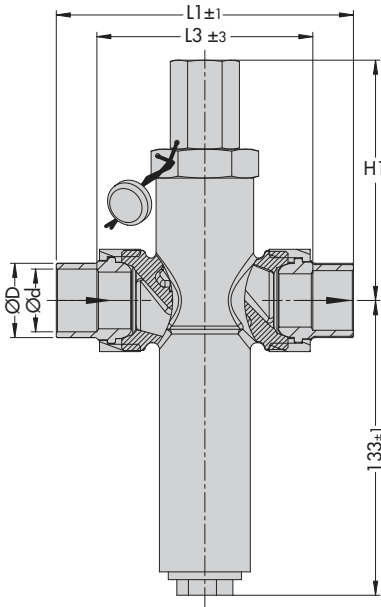

Connecting parts with **spherical liner**

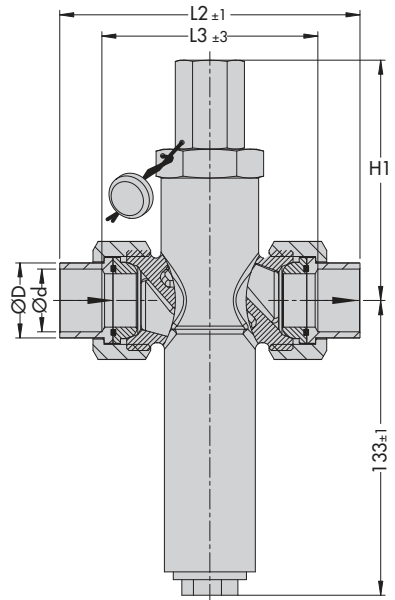

Connecting parts with **flat gasket**

### Soldering nipple (brass)

Dimensions in mm	DN 15	DN 25
L3	100	
Ø d	For pipe Ø 16	For pipe Ø 28

### Height H1

Without set point indication:  $H1 = 108 \pm 1$  mm

With set point indication:  $H1 = 116 \pm 1$  mm

**Weight:** 1.8 kg (without connecting parts)

### Welding ends (stainless steel)

Dimensions in mm	DN 15	DN 25
L1	155	
L2	165	
Ø d	16.1	28.5
Ø D	21.3	33.7

Fig. 5 - Dimensions

## 7 Technical data

**Table 1** · Technical data · All pressures in bar (gauge)

Type 2040 Safety Temperature Monitor	
Body connection	G 1¼ (see Fig. 4 for connecting parts)
K <sub>VS</sub> coefficient	5
Set point ranges	-30 °C to +10 °C -45 °C to -10 °C <sup>1)</sup>
Max. perm. operating pressure	40 bar
Max. perm. differential pressure Δp	25 bar
Leakage rate	≤ 0.05 % of K <sub>VS</sub> at -10 °C ≤ 0.1 % of K <sub>VS</sub> at -45 °C
Hysteresis	2 K
Accuracy	±1 °C
Permissible temperature range	-60 °C to +60 °C
Temperature differential between open/closed	17 K

<sup>1)</sup> On request

**Table 2** · Materials · Material number according to DIN EN

Type 2040 Safety Temperature Monitor	
Body	CC491K (G-CuSn5ZnPb)
Bellows	CW453K (CuSn8F40)
Spring	1.4310
O-ring	NBR
Seat	CW617N (CuZn40Pb2)/NBR
Tubular plug	1.4571/1.4404

## 8 Nameplate

Laser inscription on the regulator body

_____	Set point temperature with unit
_____	Flow of direction
_____	Production number: 3- ...
_____	Model number with modification index
_____	Valve coefficient $K_{VS} = 5$
_____	Test mark <sup>1)</sup>
_____	Keep regulator free of oil and grease

<sup>1)</sup> Omitted at a set point temperature between  $-31\text{ °C}$  and  $-45\text{ °C}$

*Fig. 6 - Nameplate specifications*



SAMSON AG · MESS- UND REGELTECHNIK  
Weismüllerstraße 3 · 60314 Frankfurt am Main · Germany  
Phone: +49 69 4009-0 · Fax: +49 69 4009-1507  
Internet: <http://www.samson.de>

**EB 2090 EN**

S/Z 2016-12