

Thermostats

Type 2231 and Type 2232 Bulb Sensor

Type 2233, Type 2234 and Type 2235 Air Sensor

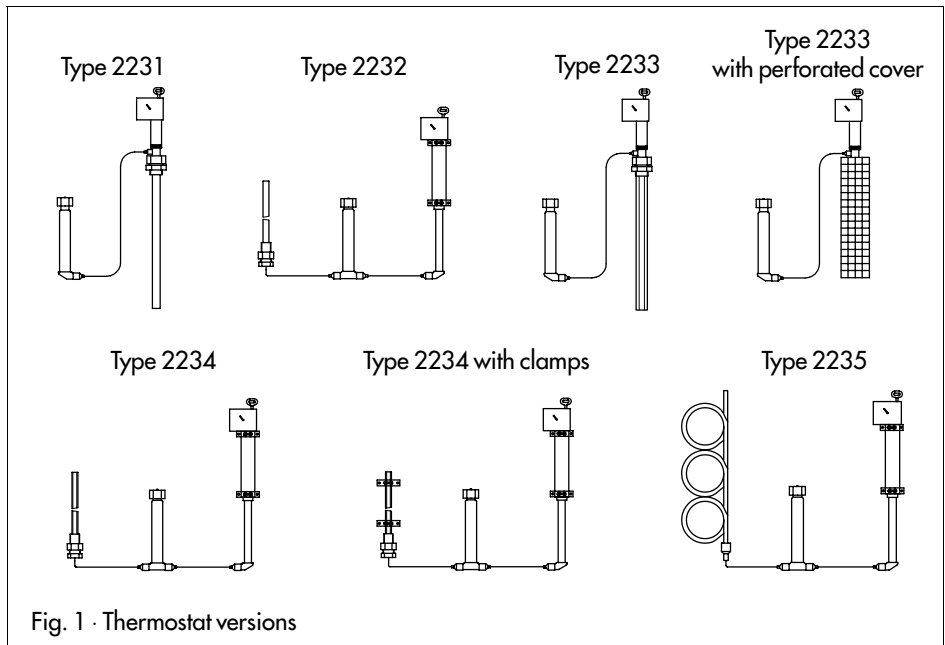

Fig. 1 · Thermostat versions

1. Design and principle of operation

The thermostat is used in combination with a control valve to control the temperature.

The thermostat can be attached directly to the valve or via a double adapter. A double adapter with or without locking facility allows

the attachment of additional thermostats to control or limit the temperature.

The thermostat consists of a temperature sensor, a set point adjustment, a capillary tube and an operating element.

The versions illustrated above are chosen according to the application intended.

The thermostats function according to the principle of liquid expansion. For example, if the temperature at the sensor (19) rises, the expanding fluid contained in the sensor bellows (10) the operating element pin (9) upwards. This travel motion moves the plug stem of the attached control valve until the temperature reaches the set point adjusted .

The temperature set point is adjusted by turning a key (12). This key moves the piston (18) up or down via a spindle. The change in volume produced in the sensor (19) causes

the valve plug to move through its full travel range within a higher or lower temperature range measured by the sensor and depending on the set point adjusted.

Typetesting:

Type 2231 to Type 2235 Control Thermostats have been typetested by the German Technical Inspectorate (TÜV) in combination with the control valves according to DIN 3440 .

Register Numbers are available on request.

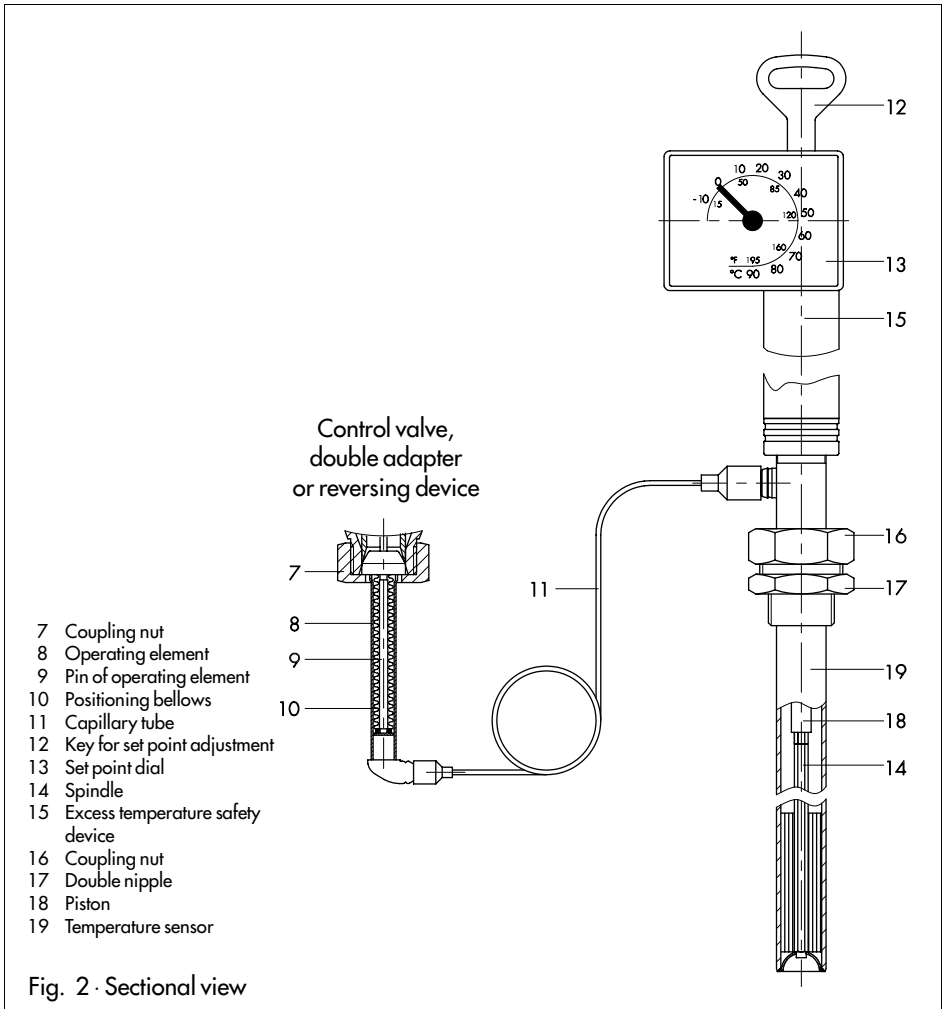

2. Installation

2.1 Types 2231 and 2232 (Bulb Sensor)

Bulb sensors are used to measure the temperature of liquids. They are designed for installation in pipelines, heat exchangers, boilers, baths, tanks etc. The sensor should be installed as close to the heat source as possible. However, it is important to make sure that it cannot overheat.

When installed in a boiler, the sensor should be located in the top third of the boiler.

In a counter-flow heat exchanger, the sensor should be installed in a pipe elbow directly behind the pipe end socket piece.

In plants where the heat consumption is not constant, a circulating pipe should be fitted on installing the regulator in the counter-flow heat exchanger. This ensures that the sensor can respond to temperature changes even when no water is drained from the counter-flow heat exchanger.

Weld an approx. 40 mm long pipe connection (welding socket) with a female thread where the sensor is to be installed (also when a thermowell is used). Remove the double nipple (17) or the thermowell (if used) from the sensor (19). Push it into the welding socket and seal it.

Adjust the set point dial (13) using the key (12) to the highest value. Place the sensor with the sealing ring into the double nipple or into the thermowell and secure it with the coupling nut (16). The whole length of the temperature sensor (19) or the thermowell must be immersed in the medium to be controlled.

Thermowell: When using a thermowell, it is recommended that the free space between the sensor and the thermowell is filled with oil, or when the thermowell is to be installed horizontally, with grease or another heat transfer substance. This prevents delays occurring on transferring the heat (note: the filling substance expands due to heat, therefore do not fill up completely the free space or alternatively, do not screw tight the sensor nut in order to compensate for the pressure).

To prevent damage caused by corrosion, it is important to make sure on installing a sensor

or a thermowell that only the same kind of materials are used together. For example, avoid using a sensor or thermowell made of non-ferrous metal in a stainless steel heat exchanger. In this case, the sensor should be used together with a stainless steel thermowell.

2.1.2 Types 2233, 2234 and 2235 (Air Sensor)

Types 2233 and 2234 are used for installation in air heaters, air ducts, drying cabinets etc. The sensor must be installed from outside into the unit concerned and fixed with a special flange (accessories). The sensor should be installed in such a way that its whole length is exposed to the air flow to be controlled.

In the case of Type 2234, the set point adjustment must be assembled in an easily accessible location.

The ambient temperature should be kept as even as possible.

Type 2233 with perforated cover is generally suitable for production halls, living rooms, swimming baths, etc.

The sensor which is protected in a perforated cover should be fixed in a suitable location, if possible on the middle of a wall.

Type 2234 with clamps (or perforated cover) is suitable for drying chambers, dryers, incubators etc.

The sensor should be installed close to the air inlet when a forced air circulation is used. The set point adjustment should be located outside of the space to be controlled in a place which is easily accessible. The set point adjustment should not be exposed to considerable temperature fluctuations.

Type 2235 is equipped with a temperature sensor that has to be adjusted on site. This means almost all temperature layers can be measured. For this version, the set point adjustment should be installed outside of the space to be controlled at an easily accessible location where the temperature is kept as even as possible.

For controlling the temperature in greenhouses, make sure that the thermostat and set point adjustment are not exposed to direct sunlight. If the temperature control system is shut-down in summer, the set point should be adjusted to a high value in order to protect the thermostat.

2.1.3 Capillary tube

The capillary tube (11) should be run carefully without twisting or bending it. It should not be exposed to any temperature fluctuations, if possible.

The capillary tube may not be under any circumstances damaged or shortened. Any excess tube should be coiled up. The smallest permissible bending radius is 50 mm.

2.1.4 Operating element

Screw the operating element (8) to the valve body or double adapter using the coupling nut (7).

3. Operation

3.1 Adjusting the set point

Adjust the set point required according to the set point dial(13) only with the key (12).

Slowly turning the key clockwise increases the set point temperature, anti-clockwise lowers it.

Check the adjusted temperature at the reference thermometer in the plant and, if necessary correct the set point by turning the key.

Important: A higher set point temperature can be adjusted as required. However, a lower temperature should only be adjusted in steps of 10 to 20 °C. Wait after adjusting until the medium has cooled down correspondingly (watch the thermometer).

3.2 Correction of the set point dial

It may occur that the temperature adjusted at the set point dial does not correspond with the temperature measured by the reference thermometer due to special operating conditions. In this case, proceed as follows:

Remove the screw (labelled as the correcting screw) at the back of the dial housing. Turn the whole dial housing until the set point dial shows the same value as the reference thermometer.

Turning the dial clockwise increases the set point, and turning it anti-clockwise decreases the set point (view from the front with dial housing on top).

A 360° turn of the dial corresponds to a set point change of approx. 1.5 °C.

