

Self-operated Pressure Regulators

Excess Pressure Valve Type 2406



Type 2406 Excess Pressure Valve

Mounting and Operating Instructions

EB 2522 EN

Edition February 2010



Contents

1	Design and principle of operation	4
1.1	Process medium and field of application	4
2	Installation	4
2.1	Mounting positions	4
2.2	Strainer	6
2.3	Shut-off valve	6
2.4	Pressure gauge	6
2.5	Control line	6
3	Operation	6
3.1	Start-up.	6
3.2	Set point adjustment.	8
3.3	Decommissioning	8
4	Maintenance and troubleshooting	9
4.1	Pressure fluctuations	9
5	Nameplate	10
6	Customer service	10
7	Technical data.	11
8	Dimensions and weights.	12

Definitions of the signal words used in these instructions

WARNING!

WARNING indicates a hazardous situation which, if not avoided, could result in death or serious injury.

Note: *Supplementary explanations, information and tips*

NOTICE

NOTICE indicates a property damage message.



General safety instructions

- ▶ *The regulators must be installed, started up and serviced by fully trained and qualified personnel only, observing the accepted industry codes and practices. Make sure employees or third persons are not exposed to any danger.*
All safety instructions and warnings in these instructions, particularly those concerning installation, start-up and maintenance, must be observed.
- ▶ *According to these mounting and operating instructions, trained personnel is referred to as individuals who are able to judge the work they are assigned to and recognize possible dangers due to their specialized training, their knowledge and experience as well as their knowledge of the relevant standards.*
- ▶ *The regulator complies with the requirements of the European Pressure Equipment Directive 97/23/EC. The declaration of conformity issued for a valve bearing the CE marking includes information on the applied conformity assessment procedure.*
The declaration of conformity can be provided on request.
- ▶ *For appropriate operation, make sure that the regulator is only used in applications where the operating pressure and temperatures do not exceed the operating values based on the sizing data submitted in the order.*
- ▶ *Note that the manufacturer does not assume any responsibility for damage caused by external forces or any other external factors.*
- ▶ *Any hazards which could be caused in the regulator by the process medium or operating pressure are to be prevented by means of appropriate measures.*
- ▶ *Proper shipping and appropriate storage are assumed.*

Note: *Non-electric valve versions which do not have a valve body lined with an insulating coating do not have their own potential ignition source according to the ignition risk assessment stipulated in EN 13463-1: 2001, section 5.2, even in the rare incident of an operating fault. Therefore, they **do not** fall within the scope of Directive 94/9/EC.*

1 Design and principle of operation

See Fig. 1 on page 5.

The medium flows through the valve in the direction indicated by the arrow. The position of the valve plug (3) determines the area released between the plug (3) and seat (2).

In the idle position (control line not connected or no pressure applied), the valve is closed by the force of the set point springs (7).

The upstream pressure p_1 to be controlled is tapped upstream of the valve and transmitted via the external control line ¹⁾. This pressure is transferred to the actuator housing (6) over the control line and is converted into a positioning force by the diaphragm plate with operating diaphragm (5). This force is used to move the plug stem (4) and the valve plug as a result, depending on the force of the set point springs (7). The spring force can be adjusted at the set point adjuster (8).

When the force resulting from the upstream pressure p_1 exceeds the spring force adjusted at the set point springs, the valve opens proportionally to the change in pressure.

In the version with pressure balancing, the forces at the plug caused by the upstream and downstream pressures are eliminated by the balancing diaphragm (10). The plug is fully balanced.

1.1 Process medium and field of application

The Type 2406 Excess Pressure Valves are only suitable for controlling **gases** in the temperature range between **-20** and **+60 °C**.

¹⁾ Set points 5 to 200 mbar: internal pressure tapping on request

2 Installation

See Fig. 1 on page 5.

NOTICE

A strainer (SAMSON Type 2 NI) must be installed upstream of the regulator (see section 2.2).

The regulator must be installed free of stress. If necessary, support the piping near the connections. However, do not attach supports to the valve or actuator.

2.1 Mounting positions

Installation – preferable –

- Install the valve in a **horizontal pipeline**. The actuator with set point adjuster must **face upwards**.
- Make sure the medium flows through the valve in the direction indicated by the arrow.
- Install the control line to the tapping point with an approx. 10 % slope to allow any condensing liquid to flow back into the vessel (tank) or pipe.

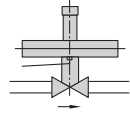

Other possible installations

- Install the valve in a **vertical pipeline**. The actuator with set point adjuster must point **to the side**.

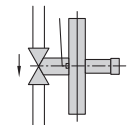

Note: System deviations may occur in this mounting position.

- The medium must flow from the top of the valve downwards.

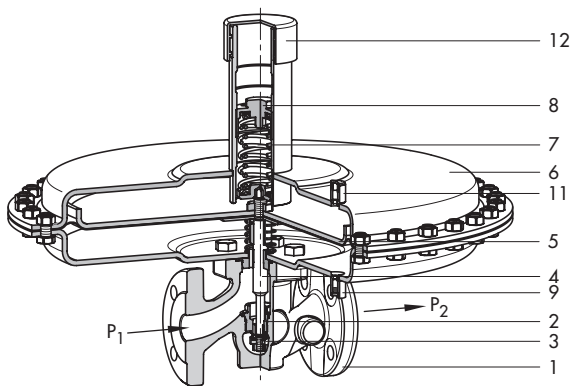

Type 2406 **without** pressure balancing

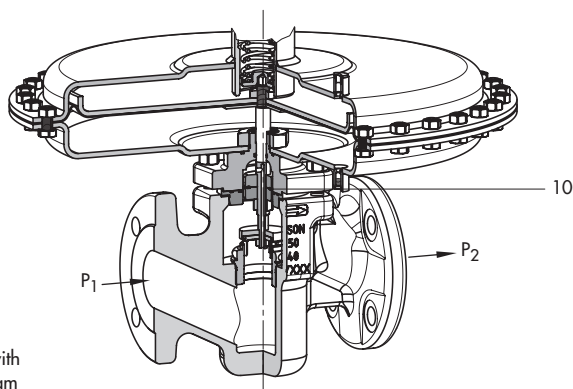

Type 2406 **with** pressure balancing

- 1 Valve body
- 2 Seat
- 3 Plug
- 4 Plug stem
- 5 Diaphragm plate with operating diaphragm
- 6 Actuator housing
- 7 Set point spring(s)
- 8 Set point adjuster (adjusting screw SW 27)
- 9 Control line connection (G ¼ tapped connection for upstream pressure p_1)
- 10 Balancing diaphragm
- 11 Venting plug or leak-off connection (special version)
- 12 Cap

Fig. 1 · Functional diagrams

2.2 Strainer

The strainer must be installed upstream of the regulator (Fig. 2). Make sure the direction of medium flow corresponds with the direction indicated by the arrow on the strainer. The filter element must be suspended to hang downwards. Remember to leave enough space to remove it.

2.3 Shut-off valve

Install a hand-operated shut-off valve both upstream of the strainer and downstream of the regulator (see Fig. 2). This allows the plant to be shut down for cleaning and maintenance and when the plant is not used for longer periods of time.

2.4 Pressure gauge

To monitor the pressures in the plant, install a pressure gauge both upstream and downstream of the regulator (see Fig. 2).

2.5 Control line

A tapped connection G ¼ (9) is located on the actuator housing. A control line with an inside diameter of min. 6 mm (preferably 8 x 1 mm, steel or stainless steel pipe) must be provided at the site of installation.

The control line connection for pressure tapping must always be directly attached to the vessel (tank) because the medium is in the expanded state and no turbulence occurs at this point.

If the pressure is to be tapped at a straight pipeline section, the largest possible distance

to the regulator must be kept (at least 2 x DN).

Connect the control line at the side or top of the horizontally running main pipeline. If possible, place the point of pressure tapping in a pipe expansion.

Install any pipe fittings (e.g. restrictions, bends or branches), that may cause turbulence in the flow, sufficiently far away from the pressure tapping points (at least 3 x DN).

Note: *If the gas to be controlled is damp, condensate may collect in the control line which could damage the controller. Install the control line with an approx. 10 % slope to the pressure tapping point in the vessel (tank) or pipe to allow the condensate to flow back into the vessel.*

3 Operation

3.1 Start-up

NOTICE

First start up the regulator after mounting all the components.

The control line must be free of dirt and the flow cross-section must be open.

Make sure the control line is correctly connected.

Open the shut-off valves **slowly** preferably starting from the flow pipe side. Avoid pressure surges (hammering).

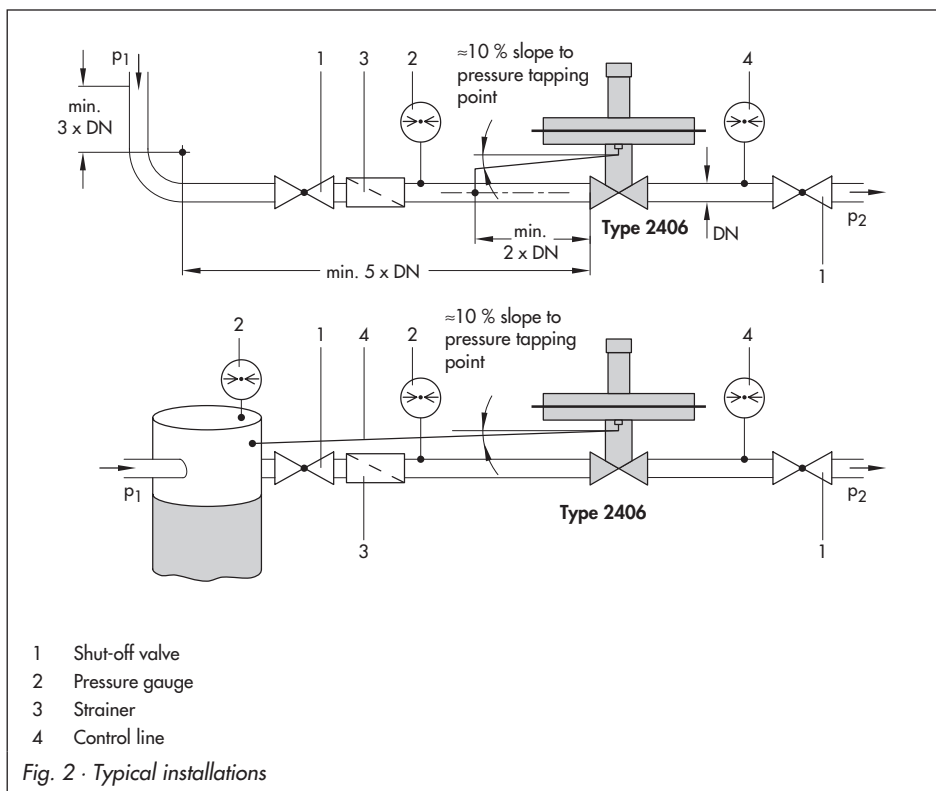

NOTICE

When testing the pressure of the plant with the regulator already installed, the nominal pressure (body) is permissible (see section 7). However, it is important that the maximum permissible pressure at the operating diaphragm is not exceeded. If this cannot be guaranteed, proceed as follows:

Unscrew the control line at the actuator and seal the open control line.

All plant components must be sized for the test pressure.

3.2 Set point adjustment

See Fig. 1 on page 5.

Adjust the required set point by tensioning the set point springs (7) at the set point adjuster (8).

- ▶ Remove cap (12).
- ▶ Use a socket wrench (SW 27) to turn the screw (8).
- ▶ Turn it clockwise to increase the set point pressure and counterclockwise to reduce the set point pressure.
- ▶ Screw back on cap (12).

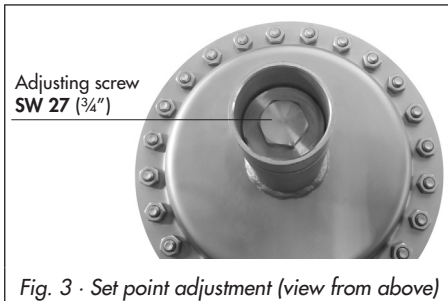

3.3 Decommissioning

Close first the shut-off valve on the upstream side and then on the downstream side.

The pressure gauge (Fig. 2) installed on the upstream side on site allows the adjusted set point to be monitored.

4 Maintenance and troubleshooting

The regulators are maintenance free. Nevertheless, they are subject to natural wear, particularly at the seat, plug and operating diaphragm.

Depending on the operating conditions, the regulator needs to be checked at regular intervals to avoid possible malfunctions.

WARNING!

On performing any work on the regulator, make sure the relevant section of the pipeline is depressurized and, depending on the process medium, drained as well.

We recommend to remove the valve from the pipeline.

For high temperatures, allow the regulator to cool down to ambient temperature before starting any work on it.

Interrupt or shut off the control line to avoid any hazards which could be caused by moving parts.

As valves are not free of cavities, remember that residual process medium might still be contained in the valve.

4.1 Pressure fluctuations

NOTICE

Pressure fluctuations (oscillations) could damage the regulator and plant. Therefore, they should not be allowed to occur or the reason for their occurrence must promptly be eliminated.

To eliminate any oscillations, the following measures may be helpful:

- ▶ Check the pressure tapping of the control line (see section 2.5). If need be, relocate the point of tapping.
- ▶ Screw SAMSON Venturi nozzle into the union for the control line connection (9) (item no. 1991-7114 for 1200/640 cm² or item no. 1991-7113 for 320/160 cm²).
- ▶ Check the sizing data used for the regulator. If necessary, change the Kvs coefficient, seat diameter or diaphragm area.

If faults cannot be remedied, contact SAMSON's After-Sales Service (see section 6).

5 Nameplate

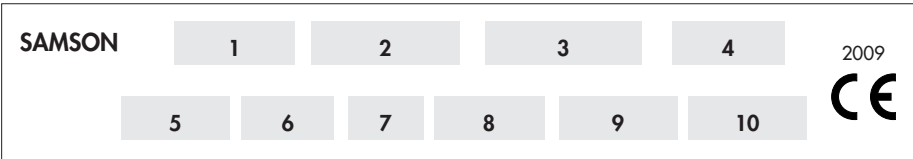

The nameplate diagram shows the following layout:

- Top left: **SAMSON**
- Field 1: Type designation (2406)
- Field 2: Configuration ID (Var.-ID)
- Field 3: Order number or order date
- Field 4: K_{VS} coefficient
- Field 5: Set point range
- Field 6: Nominal size DN
- Field 7: Nominal pressure (body)
- Field 8: Max. inlet pressure (max. perm. pressure at the operating diaphragm)
- Field 9: Perm. temperature
- Field 10: Body material
- Top right: 2009
- Bottom right: **CE** mark

Explanations

1	Type designation (2406)	6	Nominal size DN
2	Configuration ID (Var.-ID)	7	Nominal pressure (body)
3	Order number or order date	8	Max. inlet pressure (max. perm. pressure at the operating diaphragm)
4	K_{VS} coefficient	9	Perm. temperature
5	Set point range	10	Body material

Fig. 4 · Nameplate

6 Customer service

Should any malfunctions or any defect occur, SAMSON's After-Sales Service is prepared to help you on site.

You can also send the defective regulator directly to your local SAMSON representative for repair. Addresses of SAMSON subsidiaries, agencies and service centers are listed in the product catalogs and in the Internet at www.samson.de.

To allow SAMSON to find the fault and to have an idea of the installation situation, specify the following details (refer to the nameplate):

- ▶ Type and nominal size of the valve
- ▶ Configuration ID (Var.-ID)
- ▶ Upstream and downstream pressure
- ▶ Temperature and control medium
- ▶ Minimum and maximum flow rate
- ▶ Has a strainer been installed?
- ▶ Sketch of the installation with exact position of regulator and all additional installed components (shut-off valves, pressure gauges, etc.).

7 Technical data

Table 1 · Technical data

Nominal size		DN 15 to 25	DN 32 to 50 ¹⁾
Nominal pressure (body)		PN 16 · PN 25 · PN 40	
K _{V5} coefficients		1 · 1.6 · 2.5 · 4 · 6.3 · 8	6.3 · 8 · 16 · 20 · 32
Max. perm. temperature range (medium temperature)		-20 to +60 °C ²⁾	
Leakage class acc. to DIN EN 60534-4		Soft sealing, min. class IV	
Set point ranges		5 to 15 mbar · 10 to 30 mbar · 25 to 60 mbar 50 to 200 mbar 0.1 to 0.6 bar · 0.2 to 1 bar · 0.8 to 2.5 bar 2 to 5 bar	
Pressure balancing	K _{V5} = 0.4 to 4	Without balancing diaphragm	
	K _{V5} = 6.3 to 32	With balancing diaphragm	
Pressure tapping		External control line ³⁾	
Control line connection		G ¼	
Max. perm. pressure across operating diaphragm	1200 cm ² · 5 to 15 mbar	2 bar	
	1200 cm ² /640 cm ² · 10 to 30 mbar		
	320 cm ² · 25 to 60 mbar		
	320 cm ² · 50 to 200 mbar	5 bar	
	320 cm ² · 0.1 to 0.6 bar	10 bar	
	160 cm ² · 0.2 to 1 bar	16 bar	
	80 cm ² · 0.8 to 2.5 bar	16 bar	
40 cm ² · 2 to 5 bar	16 bar		

1) Larger nominal sizes on request

2) Higher temperatures on request

3) Set points 5 to 200 mbar, optionally with internal pressure tapping

8 Dimensions and weights

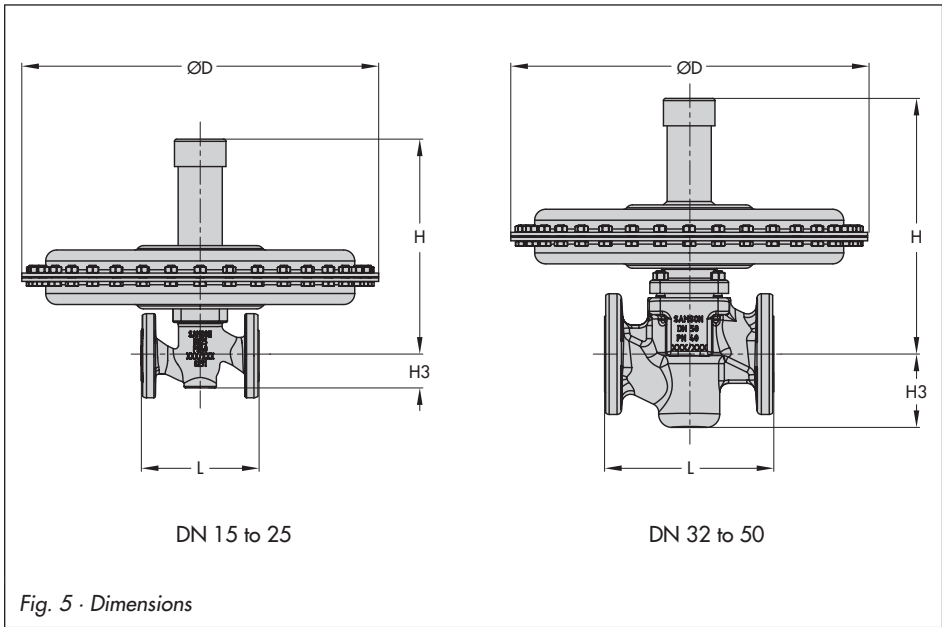

Table 2 · Dimensions in mm and weights in kg

Nominal size		DN	15	20	25	32	40	50
Valve	Length L		130	150	160	180	200	230
	Height H3	Other materials	55			72		
		Forged steel	53	–	70	–	92	98
Set point range								
5 to 15 mbar	Height H		330			365		
	Actuator		∅ D = 490, A = 1200 cm ²					
10 to 30 mbar	Height H		–			365		
	Actuator		–			∅ D = 490, A = 1200 cm ²		
10 to 30 mbar	Height H		325			–		
	Actuator		∅ D = 380, A = 640 cm ²			–		
25 to 60 mbar	Height H		–			360		
	Actuator		–			∅ D = 380, A = 640 cm ²		
25 to 60 mbar	Height H		325			–		
	Actuator		∅ D = 285, A = 640 cm ²			–		
50 to 200 mbar	Height H		325			360		
	Actuator		∅ D = 285, A = 320 cm ²					
0.1 to 0.6 bar	Height H		325			360		
	Actuator		∅ D = 285, A = 320 cm ²					
0.2 to 1 bar	Height H		325			360		
	Actuator		∅ D = 225, A = 160 cm ²					
0.8 to 2.5 bar	Height H		320			355		
	Actuator		∅ D = 170, A = 80 cm ²					
2 to 5 bar	Height H		320			355		
	Actuator		∅ D = 170, A = 40 cm ²					
5 to 15 mbar	Weight ¹⁾ in kg, approx.		28			40		
10 to 30 mbar			18					
25 to 60 mbar						30		
50 to 200 mbar			14			26		
0.1 to 0.6 bar								
0.2 to 1 bar			10			22		
0.8 to 2.5 bar			8			20		
2 to 5 bar			8			20		

¹⁾ Body made of cast steel 1.0619: +10 %



SAMSON AG · MESS- UND REGELTECHNIK
Weismüllerstraße 3 · 60314 Frankfurt am Main · Germany
Phone: +49 4009-0 · Fax: +49 69 4009-1507
Internet: <http://www.samson.de>

EB 2522 EN

S/Z/2010-02