

Pressure Reducing Valve Type 2422/2424

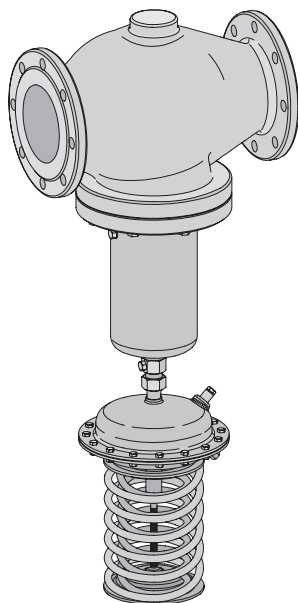

Type 2422/2424 Pressure Reducing Valve

Mounting and Operating Instructions

EB 2547 EN

Edition October 2006



Contents	Page	
1	Design and principle of operation	4
2	Installation	6
2.1	Assembly	6
2.2	Position of installation	6
2.3	Condensation chamber	6
2.4	Control line	6
2.5	Screw joint with restriction	7
2.6	Strainer	7
2.7	Shut-off valves	7
2.8	Pressure gauges	7
3	Operation	8
3.1	Start-up	8
3.2	Set point adjustment	8
3.3	Shut-down	8
4	Troubleshooting	9
4.1	Replacing the diaphragm	9
5	Nameplates	10
6	Dimensions and weights	11
7	Customer service	13

Note!

*The non-electric actuators and valve versions do not have their own potential ignition source according to the ignition risk assessment stipulated in EN 13463-1: 2001, section 5.2, even in the rare incident of an operating fault. Therefore, they **do not** fall within the scope of Directive 94/9/EC.*

For connection to the equipotential bonding system, observe the requirements specified in EN 60079-14: 1977 (VDE 0165 Part 1), section 6.3.



General safety instructions

- ▶ *The regulator must be installed, started up, and serviced only by skilled or semi-skilled staff in accordance with good engineering practice so that employees and third persons are not exposed to danger.*
- ▶ *All safety instructions and warnings given in these mounting and operating instructions, particularly those concerning installation, start-up, and maintenance, must be strictly observed.*
- ▶ *The regulator complies with the requirements of the European Pressure Equipment Directive 97/23/EC. The declaration of conformity issued for a valve bearing the CE marking includes information on the applied conformity assessment procedure and will be provided on request.*
- ▶ *To ensure appropriate use, only use the regulator in applications where the operating pressure and temperatures do not exceed the operating values specified in the order.*
- ▶ *Note that the manufacturer does not assume any responsibility for damage caused by external forces or any other external factors.*
- ▶ *Take appropriate safety precautions to prevent hazards that may be caused in the regulator by the process medium, operating pressure, or moving parts.*
- ▶ *Make sure the regulator is carefully and properly shipped, stored, assembled, installed, operated, and serviced.*

Important!

- ▶ *Prior to starting up the regulator, always assemble all components, make sure that the control lines are open, and check them for correct connection.*
- ▶ *Fill the plant very slowly on start-up.*
- ▶ *Always depressurize the relevant section of the plant and, if necessary, also drain the pipeline prior to removing the regulator from the pipeline.*
- ▶ *Depending on the field of application, allow the regulator to cool down or warm up to reach ambient temperature prior to starting any work.*
- ▶ *When controlling freezing media, protect the regulator against frost. In cases where the regulator is installed in areas subject to frost, it must be removed when the plant is shut down.*

1 Design and principle of operation

The Type 2422/2424 Pressure Reducing Valve consists of the Type 2422 Valve and the Type 2424 Actuator.

The pressure reducing valve is designed to maintain the pressure downstream of the valve at the adjusted set point. The valve closes when the downstream pressure rises.

The process medium flows through the valve between the seat (2) and plug (3) in the direction indicated by the arrow. The position of the valve plug determines the flow rate and hence the pressures across the valve. The downstream pressure p_2 is transmitted via the control line (19) to the operating diaphragm (9) where it is converted into a positioning force. This force is used to position the valve plug against the force of the positioning springs (11). The spring force can be adjusted using the set point adjuster (13).

The valve is equipped with a balancing bellows (5). The upstream pressure acts on the outside and the downstream pressure acts on the inside of the bellows. In this way, the forces produced by the upstream and downstream pressures acting on the plug are balanced by means of the balancing bellows.

Legend to Figure 1

1	Valve body	11	Positioning springs
2	Seat	13	Set point adjuster
3	Plug	14	Lower diaphragm shaft
4	Plug stem	15	Bolt and nut
5	Balancing bellows	16	Nut
6	Bellows housing	17	Diaphragm plate
6.1	Vent screw	18	Control line connection, if necessary with restriction
6.2	Vent screw	19	Control line
7	Coupling nut	20	Condensation chamber for temperatures above 150 °C and steam
8	Upper diaphragm shaft	21	Filler plug
8.1	Nut		
9	Operating diaphragm		

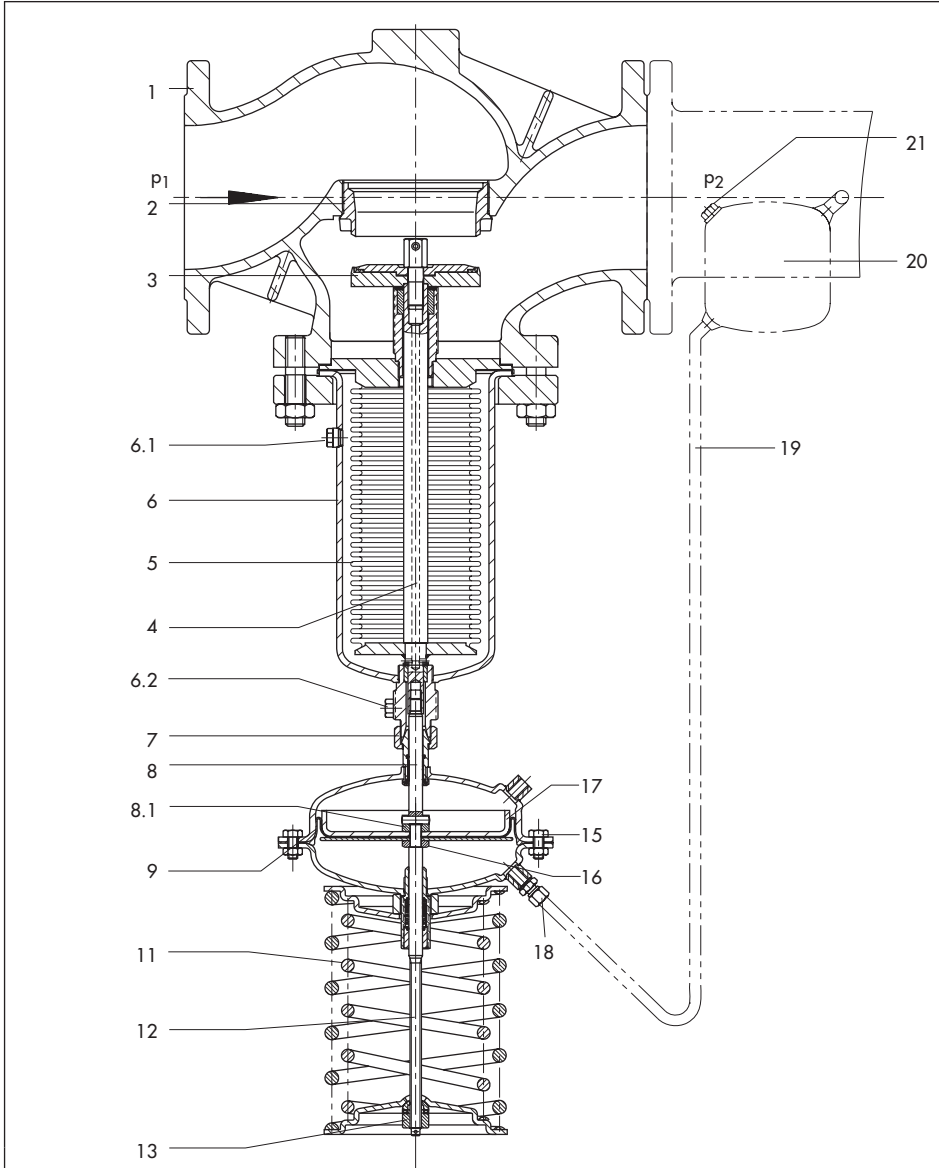

Fig. 1 · Design and principle of operation

2 Installation

2.1 Assembly

The actuator can be attached to the valve before or after installing the valve in the pipeline.

- ▶ Reduce the compression of the positioning springs to zero by turning the set point adjuster (13).
- ▶ Place the actuator on the bellows housing and carefully screw it into the thread as far as it will go. Then unscrew it by one turn at most.
- ▶ Hold the actuator and fasten it to the bellows housing using the coupling nut (7), making sure that the control line connection is in the correct position facing the downstream pressure side.

2.2 Position of installation

Caution!

Flush the pipeline thoroughly prior to installing the valve to prevent sealing particles, weld spatter, pipe scale, and other impurities carried along by the process medium from impairing the proper operation, especially the tight shut-off of the valve.

A strainer (SAMSON Type 2) must be installed upstream of the pressure reducing valve (see Fig. 2).

Install the pressure reducing valve in a horizontal pipeline with the actuator vertically suspended. Make sure that the medium flows through the valve in the direction indicated by the arrow on the valve body.

For process media with a tendency to condense, install the pipeline with a gentle downward slope on both sides so that the condensate can flow off properly.

On choosing the point of installation, make sure that the regulator can still be easily accessed after completion of the plant.

Install the regulator free of stress. If necessary, support the piping near the connecting flanges.

Caution!

Never attach any supports to the valve or actuator.

If you want to install a bypass line, connect it downstream of the pressure tapping point. Install a shut-off valve in the bypass line.

2.3 Condensation chamber

A condensation chamber is required for liquids at temperatures above 150 °C and for steam. The installation position of the condensation chamber is indicated by a label on the chamber itself as well as by an arrow and the German word "oben" (i.e. "top") stamped on top of the chamber. It is important to adhere to this installation position, since otherwise the safe functioning of the pressure reducing valve cannot be guaranteed.

2.4 Control line

A control line must be provided on site by means of a 3/8" pipe. If the control line is made of copper, we recommend using a 12 x 1 mm pipe.

Weld the control line coming from the pressure tapping point to the 3/8" pipe socket on the condensation chamber.

The condensation chamber must always be installed at the highest point of the pipeline. Consequently, the control line between the condensation chamber and the actuator must be installed with a gentle downward slope, too. For this purpose, use a 3/8" pipe with a threaded connection.

Connect the control line to the downstream pressure line (p_2) at least 1 meter downstream of the valve outlet (refer to Fig. 2).

2.5 Screw joint with restriction

Should the regulator tend to hunt, we recommend installing a SAMSON screw joint with restriction in the control line connection (18).

2.6 Strainer

The strainer must be installed upstream of the pressure reducing valve.

Make sure the process medium flows through the strainer in the direction indicated by the arrow on the strainer body. Install the strainer with the filter element vertically suspended. Ensure that ample space is available to remove the filter at a later time.

2.7 Shut-off valves

Ideally, install hand-operated shut-off valves both upstream of the strainer and downstream of the pressure reducing valve. This allows the plant to be shut down for cleaning and maintenance routines, or when the plant is not operated for long periods of time.

2.8 Pressure gauges

To monitor the pressures prevailing in the plant, install pressure gauges both upstream and downstream of the regulator, making sure that the pressure gauge on the downstream pressure side is installed downstream of the pressure tapping point.

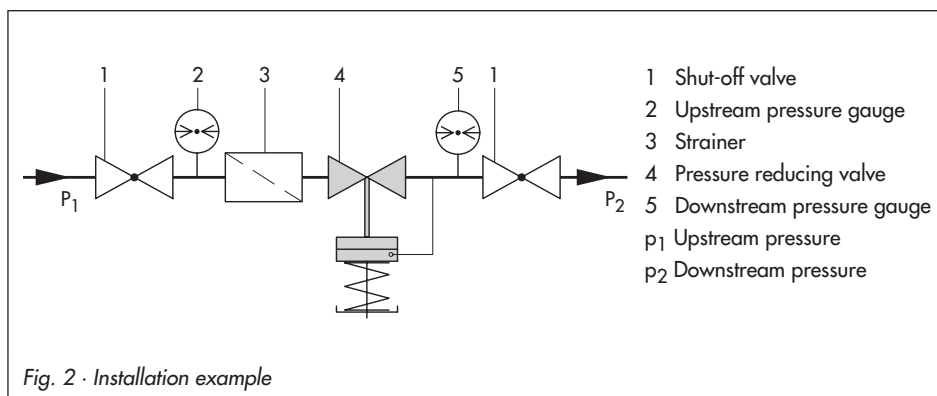

3 Operation

3.1 Start-up

For regulating steam

Unscrew the filler plug (21) of the condensation chamber. Use either the plastic funnel included in the delivery or a can to pour water into the condensation chamber until it starts to overflow. Screw the filler plug into the condensation chamber and tighten it. The pressure reducing valve will then be ready for operation.

Caution!

Open the hand-operated shut-off valves very slowly to prevent water hammering.

For regulating liquids

For medium temperatures above 150 °C, first fill the condensation chamber with the process medium. To start up the pressure reducing valve, slowly open the shut-off valves. For actuators with an effective diaphragm area of 640 cm², loosen the vent screw until all the air has escaped, then retighten.

3.2 Set point adjustment

The downstream pressure required can be adjusted by turning the set point adjuster (13).

Clockwise

 Turn the set point adjuster clockwise to increase the downstream pressure (high pressure set point)

Counterclockwise

 Turn the set point adjuster counterclockwise to reduce the downstream pressure (low pressure set point).

If the downstream pressure p_2 rises above the adjusted set point, the valve will close proportionally to the change in pressure.

The pressure gauge located on the downstream pressure side allows the adjusted set point to be monitored.

Caution!

The max. permissible pressure of the diaphragm actuator is:

1.5 bar for an effective area of 640 cm²

3 bar for an effective area of 320 cm²

When carrying out a pressure test on the section of the plant equipped with the pressure regulator, prevent the diaphragm actuator from being damaged by the test pressure by using a test pressure which does not exceed the maximum permissible pressure of the diaphragm actuator indicated above.

Changing the set point range

The set point range is determined by the size of the actuator and its positioning springs. The set point range can only be changed by replacing the whole actuator. Therefore we recommend that you contact SAMSON if you want to change the set point range.

3.3 Shut-down

First close the shut-off valves upstream of the pressure reducing valve in any order and then close the shut-off valve downstream of the pressure reducing valve.

4 Troubleshooting

Should the downstream pressure deviate significantly from the adjusted set point, first check the control line for any blockages and the operating diaphragm for any leaks.

In case of other causes, such as a damaged seat or plug, we recommend that you contact SAMSON's customer service center or return the regulator to your local SAMSON representative for repair.

If the diaphragm is damaged, proceed as described in section 4.1

4.1 Replacing the diaphragm

Caution!

Shut down the plant by slowly closing the shut-off valves. Depressurize the relevant section of the plant and drain it, if necessary.

You can separate the actuator from the valve without having to remove the valve from the pipeline.

Caution!

Note that the actuator cone serves to seal the bellows housing and that the valve will drain upon removing the actuator from the valve.

1. Reduce the compression of the spring assembly to zero by turning the set point adjuster (13) counterclockwise.
2. Unscrew the control line and clean it.
3. Loosen the coupling nut (7). Then remove the actuator.
4. Unscrew the set point adjuster (13). Then take off the bearing and bushing as well as the spring(s) and spring plate.
5. Remove the nuts and bolts (15). Then lift the top cover plate off the actuator stem.
6. Pull the diaphragm shafts together with the diaphragm plates and the diaphragm out of the lower diaphragm case.
7. Hold the bottom nut (16) stationary using a socket wrench and unscrew the top diaphragm shaft by loosening the nut (8.1) (the nut is sealed with paint!).
8. Take off the top diaphragm plate (17). Then replace the operating diaphragm (9) with a new one.

To reassemble the regulator, proceed in reverse order. And to start up, proceed as described in section 3.1.

5 Nameplates

Both the valve and the actuator bear a nameplate.

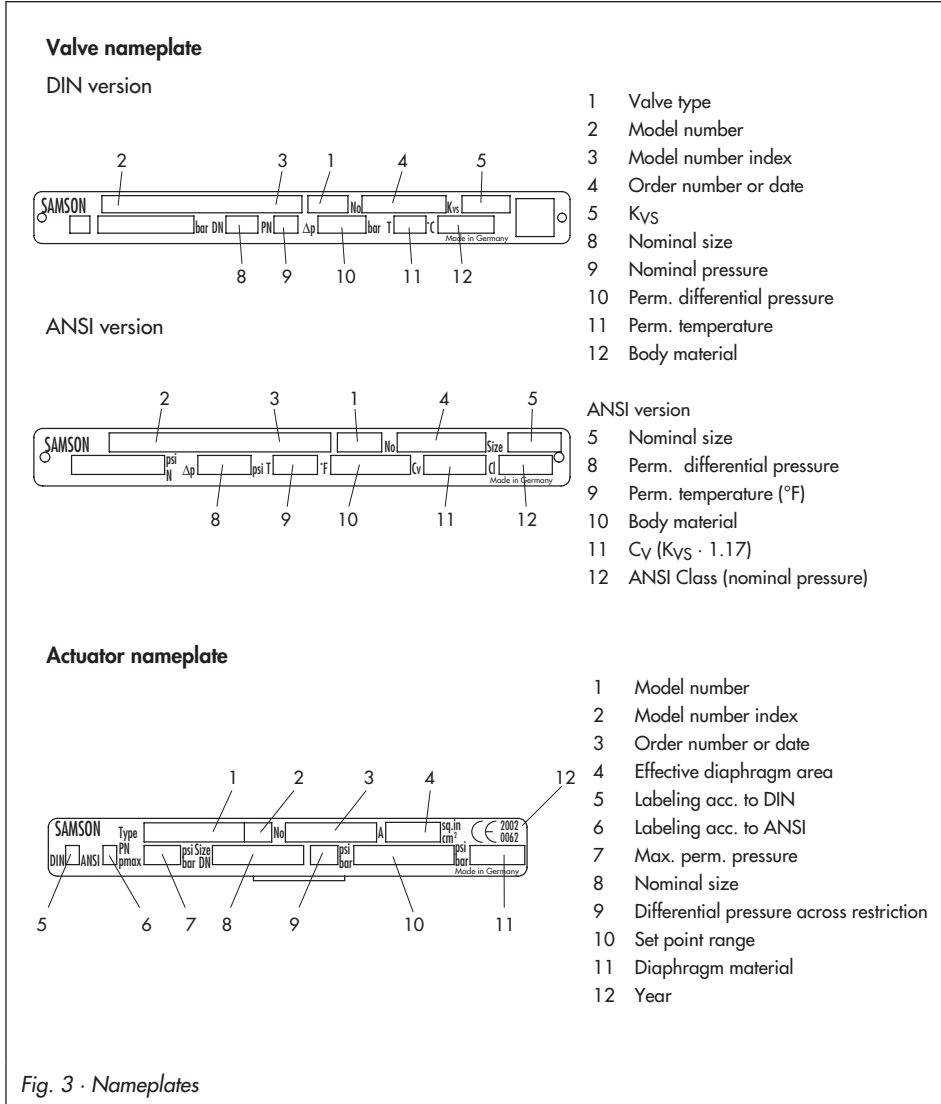

Fig. 3 · Nameplates

6 Dimensions and weights

Table 1 · Dimensions in mm and weights in kg · The values in parentheses apply to temperatures from 220 °C to 350 °C.

Type 2422/2424 Pressure Reducing Valve						
Nominal size DN			125	150	200	250
Length L			400	480	600	730
Length L1	PN 16		635	740	-	
	PN 40		650	760	-	
Height H1			460 (600)	590 (730)	730 (870)	
Height H2			145	175	270	
Set point ranges in bar	0.05 to 0.25	Height H	990 (1190)	1120 (1260)	1260 (1400)	
		Actuator	∅ D = 380 mm, A = 640 cm ²			
		Valve spring force	2150 N			
	0.1 to 0.6	Height H	990 (1130)	1120 (1260)	1260 (1400)	
		Actuator	∅ D = 380 mm, A = 640 cm ²			
		Valve spring force	3600 N			
	0.2 to 1.0	Height H	990 (1130)	1120 (1260)	1260 (1400)	
		Actuator	∅ D = 380 mm, A = 640 cm ²			
		Valve spring force	8000 N			
	0.5 to 1.5	Height H	910 (1050)	1040 (1180)	1180 (1320)	
		Actuator	∅ D = 285 mm, A = 320 cm ²			
		Valve spring force	4600 N			
	1 to 2.5	Height H	910 (1050)	1040 (1180)	1180 (1320)	
		Actuator	∅ D = 285 mm, A = 320 cm ²			
		Valve spring force	8000 N			
0.05 to 1.0	Weight ¹⁾ for cast iron PN 16 in kg, approx.	135	185	425	485	
0.5 to 1.5/1 to 2.5		125	175	415	475	

¹⁾ +10% for cast steel PN 40 and spheroidal graphite iron PN 25

Dimensions

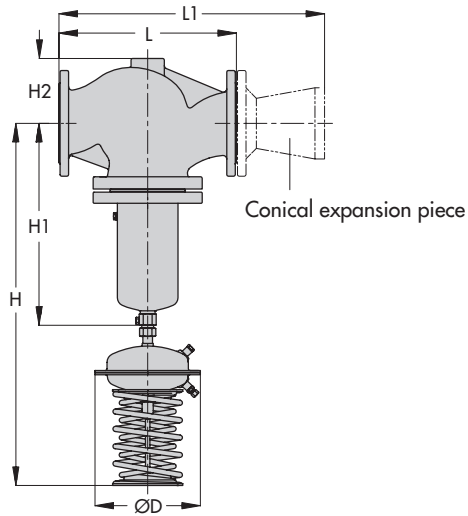

Fig. 4 · Dimensional drawing

7 Customer service

Should any malfunctions or any defect occur, SAMSON's After-Sales Service is prepared to help you on site. You can also send the defect regulator directly to your local SAMSON representative for repair.

To allow SAMSON to find the error and to have an idea of the installation situation, we kindly ask you to specify the following details:

- ▶ Type, nominal size, and set point range of the regulator
- ▶ Order number
- ▶ Model numbers of the valve and the actuator
- ▶ Upstream and downstream pressures
- ▶ Flow rate in m³/h
- ▶ Medium temperature and control medium
- ▶ Min. and max. medium temperatures
- ▶ Installation drawing that exactly indicates the location of the regulator and all additionally installed components including the shut-off valves, pressure gauges, strainers, etc.



SAMSON AG · MESS- UND REGELTECHNIK
Weismüllerstraße 3 · 60314 Frankfurt am Main · Germany
Phone: +49 69 4009-0 · Fax: +49 69 4009-1507
Internet: <http://www.samson.de>

EB 2547 EN

S/Z 2006-10