



Fig. 1 · Type 33-7

1. Design and principle of operation

The excess pressure valve comprises a globe valve and an actuator with an attached pilot valve.

The excess pressure valve is designed for maintaining the pressure upstream of the valve at a set point value adjusted on the pilot valve.

The valve opens when the upstream pressure rises.

Typetest:

The device has been typetested as safety excess pressure valve (SEV) by the German Technical Inspectorate TÜV (Technischer Überwachungsverein). Test mark on request.

The medium flows through the free area between the seat (2) and plug (3) in the direction indicated by the arrow. The plug position determines the upstream (excess) pressure to be controlled. Any forces acting on the valve plug are balanced by a balancing bellows (5).

The upstream pressure p_1 is supplied as auxiliary energy to the pilot valve via a control line (10.1), causing the pilot valve to produce a control pressure p_s as a function of the value adjusted on the set point adjuster (9).

In controlling, the forces which are produced on both sides of the operating diaphragm (6) are compared. Here, the force of the upstream pressure p_1 acts on one side of the diaphragm via the

control line (10), and the force of the control pressure p_s , together with the force of the positioning springs, acts on the other side.

If, e.g., the upstream pressure rises, the operating diaphragm and the plug stem with the connected plug move in the opening direction, against the force produced by the control pressure p_s and the springs (7), until the pressure across the valve equals the adjusted set point value.

If the upstream pressure falls, this process is reversed. Since the force produced by the springs and the control pressure p_s is larger than that of the upstream pressure, the plug moves in the closing direction until the pressure across the valve equals the set point value.

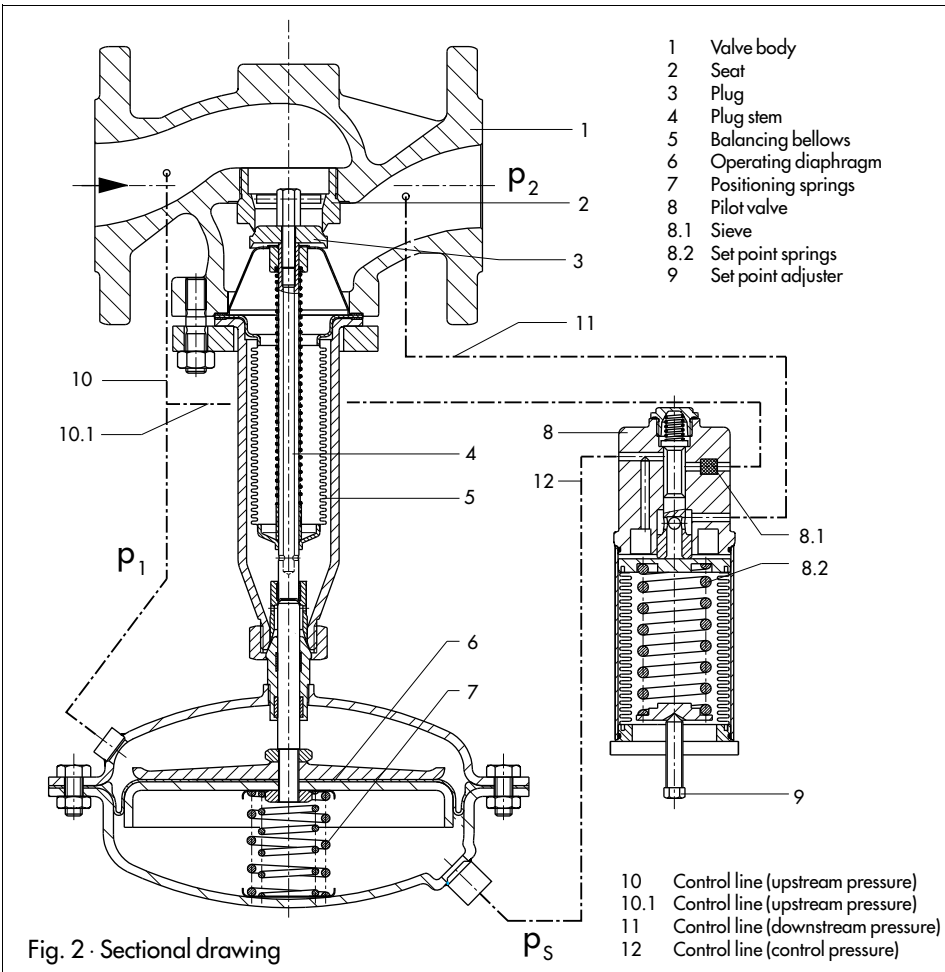

If the control pressure p_s equals the upstream pressure p_1 , the valve is closed by the force of the positioning springs (7).

Important:

For proper functioning of the regulator, the minimum differential pressure Δp_{min} across the valve has to be as stated in the table below.

DN	65	80	100	125	150	200	250
Δp_{min} bar	0.4		0.5		0.6		
Δp_{max} bar	16		12		10		
p_{1max}	16						
K_{vs} value	50	80	125	190	280	420	500
$K_{vs}^{-0.3}$ value	1.6	1.7	2	2.4	3	5	5

2. Installation

The excess pressure valve is to be installed in a horizontal pipeline with the actuator suspended vertically below the pipeline.

The direction of medium flow must coincide with the arrow on the body.

When selecting the location of installation, ensure that the regulator remains easily accessible after the plant has been installed.

Do not put excessive stress on the valve body when installing it in the plant. If necessary, support the piping near the valves flanges. Do not, however, mount these supports on the valve or control line.

Before installing the regulator, thoroughly flush out the pipeline, since sealing parts, globule and other impurities carried along by the process medium can impair proper func-

tion of the valve, especially tight shut-off. Always install a strainer (SAMSON Type 2 NI) upstream of the valve.

Attention: Even when a strainer has been installed, dirt particles can still impair the tight shut-off of the valve, depending on the mesh width of the strainer insert.

When a SAMSON strainer is used, the maximum leakage rate caused by contamination of the valve can correspond to the $K_{vs-0.3}$ value given in the table on the left. This value is relevant for sizing the safety excess pressure valve.

2.1 Strainers

Install the strainer at or near the inlet port of the excess pressure valve. The direction of medium flow must coincide with the arrow on the body.

Make sure that the filter element is vertically suspended and that ample space is available to disassemble the filter.

2.2 Shut-off valves and pressure gauges

We recommend that a hand-operated shut-off valve be installed both upstream of the strainer and downstream of the excess pressure valve. This will allow the plant to be isolated when cleaning or maintenance is required or for extended unused periods.

To observe the pressures prevailing in the plant, install a pressure gauge both preceding and succeeding the regulator.

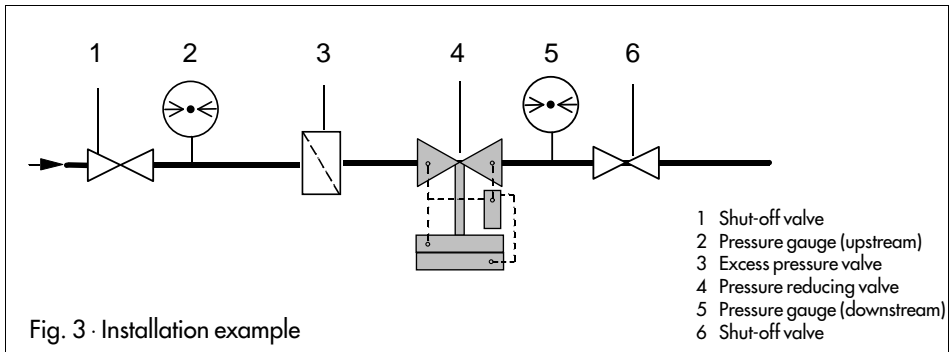

3. Operation

3.1 Start-up

Take excess pressure valve into operation by slowly opening the shut-off valve upstream of the valve. Then, slowly, open the shut-off valve downstream of the valve.

3.2 Set point adjustment

Adjust the upstream pressure (excess pressure) to the desired set point by turning the set point adjuster (9) at the pilot valve (8).

Turn clockwise (right) to increase the upstream pressure, counterclockwise (left) to decrease the pressure. The pressure gauge on the upstream side facilitates checking of the adjusted set point.

4. Faults

Should the excess pressure (see pressure gauge upstream of the valve) deviate considerably from the adjusted set point, first check the passage of the control lines.

If necessary, remove and clean the sieve (8.1) located in the inlet port of the pilot valve to which the upstream control line is connected.

With other reasons for any faults, such as an untight operating diaphragm (valve remains closed), or damaged seat and plug, we recommend to contact our after sales service or return the valve to the manufacturer for repair.

5. Customer inquiries

Should you have any inquiry on the valve, please submit:

(see also name plate)

1. Type and nominal size of the regulator
2. Product and order number
3. Upstream and downstream pressure
4. Flow rate in m^3/h
5. Has a strainer been installed?
6. Installation drawing

6. Dimensions in mm and weights

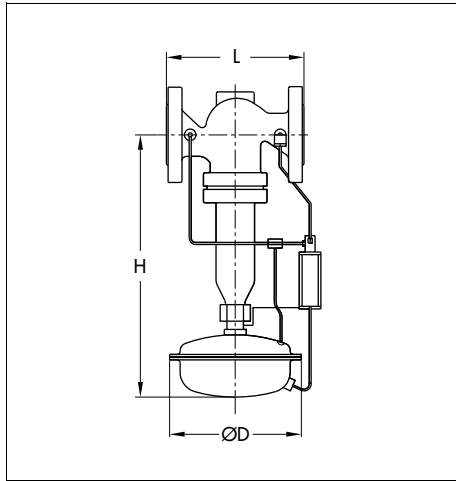

Nominal size	DN	65	80	100	125	150	200	250
Length	L	290	310	350	400	480	600	730
Height	H	605	605	635	685	815	925	925
Diaphragm case	ø D	380 (A=640 cm ²)						
Weight for PN 16 ¹⁾	kg	53	58	66	96	140	280	330

¹⁾ 10% for steel and spheroidal graphite iron PN 25



SAMSON AG · MESS- UND REGELTECHNIK
Weismüllerstraße 3 · D-60314 Frankfurt am Main
Postfach 10 19 01 · D-60019 Frankfurt am Main
Telefon (0 69) 4 00 90 · Telefax (0 69) 4 00 95 07

EB 2551-2 E

S/C 05.96

Conversion from chromate coating to iridescent passivation



Conversion from chromate coating to iridescent passivation

We at SAMSON are converting the surface treatment of passivated steel parts in our production. As a result, you may receive a device assembled from parts that have been subjected to different surface treatment methods. This means that the surfaces of some parts show different reflections. Parts can have an iridescent yellow or silver color. This has no effect on corrosion protection.

For further information, go to ► www.samson.de/chrome-en.html
