

# Self-operated Pressure Regulators

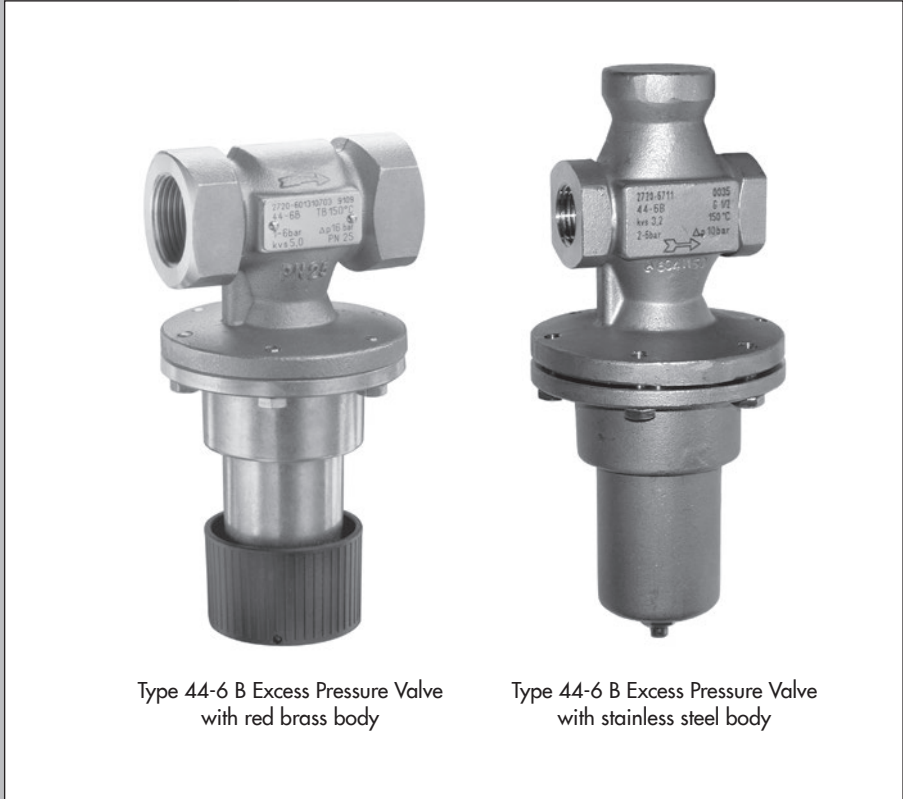

## Type 44-6 B Excess Pressure Valve



Type 44-6 B Excess Pressure Valve  
with red brass body

Type 44-6 B Excess Pressure Valve  
with stainless steel body

Translation of original instructions

## Mounting and Operating Instructions

### EB 2626-2 EN

Edition August 2016



## Note on these mounting and operating instructions

These mounting and operating instructions assist you in mounting and operating the device safely. The instructions are binding for handling SAMSON devices.

- For the safe and proper use of these instructions, read them carefully and keep them for later reference.
- If you have any questions about these instructions, contact SAMSON's After-sales Service Department (aftersaleservice@samson.de).



The mounting and operating instructions for the devices are included in the scope of delivery. The latest documentation is available on our website ([www.samson.de](http://www.samson.de)) > Product documentation. You can enter the document number or type number in the [Find:] field to look for a document.



### **WARNING!**

*Damage to health relating to REACH Regulation.*

*If a SAMSON device contains a substance which is listed as being a substance of very high concern on the candidate list of the REACH Regulation, this circumstance is indicated on the SAMSON delivery note.*

*Information on safe use of the part affected,  
see ► <http://www.samson.de/reach-en.html>*

## Definition of signal words



### **DANGER!**

*Hazardous situations which, if not avoided, will result in death or serious injury*



### **NOTICE**

*Property damage message or malfunction*



### **WARNING!**

*Hazardous situations which, if not avoided, could result in death or serious injury*



### **Note:**

*Additional information*



### **Tip:**

*Recommended action*

|           |                                                      |           |
|-----------|------------------------------------------------------|-----------|
| <b>1</b>  | <b>General safety instructions</b> .....             | <b>4</b>  |
| <b>2</b>  | <b>Process medium and scope of application</b> ..... | <b>5</b>  |
| 2.1       | Transportation and storage .....                     | 5         |
| <b>3</b>  | <b>Design and principle of operation</b> .....       | <b>5</b>  |
| <b>4</b>  | <b>Installation</b> .....                            | <b>6</b>  |
| 4.1       | Mounting position .....                              | 6         |
| 4.2       | Strainer (filter).....                               | 8         |
| 4.3       | Shut-off valve.....                                  | 8         |
| 4.4       | Pressure gauge .....                                 | 8         |
| <b>5</b>  | <b>Operation</b> .....                               | <b>9</b>  |
| 5.1       | Start-up.....                                        | 9         |
| 5.2       | Adjust the set point.....                            | 9         |
| 5.3       | Decommissioning .....                                | 9         |
| <b>6</b>  | <b>Cleaning and maintenance</b> .....                | <b>10</b> |
| 6.1       | Cleaning and exchanging the plug.....                | 10        |
| 6.2       | Replacing the operating bellows.....                 | 11        |
| 6.3       | Replacing the set point spring .....                 | 12        |
| <b>7</b>  | <b>Nameplate</b> .....                               | <b>13</b> |
| <b>8</b>  | <b>After-sales service</b> .....                     | <b>14</b> |
| <b>9</b>  | <b>Technical data</b> .....                          | <b>15</b> |
| <b>10</b> | <b>Dimensions and weights</b> .....                  | <b>16</b> |



### 1 General safety instructions

- The regulator is to be mounted, started up, or serviced by fully trained and qualified personnel only; the accepted industry codes and practices are to be observed. Make sure employees or third persons are not exposed to any danger.
- All safety instructions and warnings given in these mounting and operating instructions, particularly those concerning installation, start-up, and maintenance, must be strictly observed.
- According to these mounting and operating instructions, trained personnel refers to individuals who are able to judge the work they are assigned to and recognize possible dangers due to their specialized training, their knowledge and experience as well as their knowledge of the applicable standards.
- The regulators comply with the requirements of the European Pressure Equipment Directive 2014/68/EU. The EU declaration of conformity issued for a regulator bearing the CE marking includes information on the applied conformity assessment procedure. This declaration of conformity can be provided on request.
- To ensure appropriate use, only use the regulator in applications where the operating pressure and temperatures do not exceed the specifications used for sizing the regulator at the ordering stage.
- The manufacturer does not assume any responsibility for damage caused by external forces or any other external factors.
- Any hazards that could be caused in the regulator by the process medium, operating pressure or by moving parts are to be prevented by taking appropriate precautions.
- Proper transport, storage, installation, operation, and maintenance are assumed.

**Note:** Non-electric valve versions whose bodies are not lined with an insulating material coating do not have their own potential ignition source according to the risk assessment stipulated in EN 13463-1: 2009, section 5.2, even in the rare incident of an operating fault. Therefore, such valve versions do not fall within the scope of Directive 94/9/EC.

For connection to the equipotential bonding system, observe the requirements specified in section 6.3 of EN 60079-14: 2011 (VDE 0165 Part 1).

## 2 Process medium and scope of application

The Type 44-6 B Excess Pressure Valve is suitable for controlling gases, liquids, and steam.

### Max. permissible temperatures

- Non-flammable gases up to 80 °C
- Liquids up to 150 °C
- Nitrogen up to 200 °C
- Steam up to 200 °C



### NOTICE

*Uncontrolled excess pressure in the plant.*

*Risk of personal injury or property damage.*

*A suitable overpressure protection must be installed on site in the plant section.*

---

### 2.1 Transportation and storage

The regulator must be carefully handled, transported, and stored. Protect the regulator against adverse influences, such as dirt, moisture or frost, during storage and transportation.

## 3 Design and principle of operation

See Fig. 1 on page 7.

The excess pressure valve consists of the valve (1) with seat (2), plug (3), and balancing bellows (6) as well as a bottom section (actuator housing) with operating bellows (5), set point spring (7), and set point adjuster (8/9).

The regulator is used to maintain the pressure upstream of the valve to an adjusted set point. The valve is closed when relieved of pressure. It opens when the upstream pressure rises above the adjusted set point.

The process medium flows through the valve between seat and plug in the direction indicated by the arrow on the body. The position of the valve plug determines the flow rate and, as a result, the upstream pressure.

The upstream pressure to be kept constant is transmitted through a borehole (4) in the valve body to the operating bellows (5) where it is converted into a positioning force. This force is used to move the valve plug according to the force of the set point spring (7). The spring force is adjustable at the set point adjuster (8/9).

## 4 Installation

Choose a place of installation that allows you to freely access the regulator (especially the set point adjuster) even after the entire plant has been completed.

The type and dimensions of the pipeline and tank connections must suit the regulator being installed. The flow of direction in the pipe section must correspond with the direction indicated by the arrow on the regulator.

Observe the following instructions:

- Flush the pipeline thoroughly before installing the regulator to ensure that any impurities carried along by the process medium do not impair the proper functioning of the valve, above all the tight shut-off. Ensure that there is no liquid, e.g. condensed water, inside the regulator. If necessary, blow out the connecting parts with clean compressed air.
- Install a strainer (e.g. SAMSON Type 2 NI) upstream of the regulator (see section 4.2).
- Make sure the regulator is installed free of stress. If necessary, support the pipeline near to the connecting flanges. Do not attach supports directly to the valve or actuator.
- Protect the regulator from icing up when controlling media that can freeze. Remove the regulator from the pipeline when the plant is shut down if the regulator is not installed areas free from frost.

### NOTICE

*Possible malfunction and damage due to adverse effects of weather conditions (temperature, humidity). Overheating due to excessive ambient temperatures or insufficient heat dissipation must not occur at the site of installation.*

*As a result, do **not** insulate regulators with red brass bodies when insulating the pipeline conveying the process medium.*

*Do not install the regulator outdoors or in rooms prone to frost. If such a location cannot be avoided, protect the regulator against freezing up if the process medium flowing through the valve can freeze up. Either heat the regulator or remove it from the plant and completely drain the residual medium.*

### 4.1 Mounting position

The direction of flow must match the direction indicated by the arrow on the body.

- For liquids and gases  $\leq 150\text{ }^{\circ}\text{C}$ : any mounting position possible
- For steam  $\geq 150\text{ }^{\circ}\text{C}$ : horizontal pipeline, actuator housing suspended (see photo)



Valve

Actuator housing

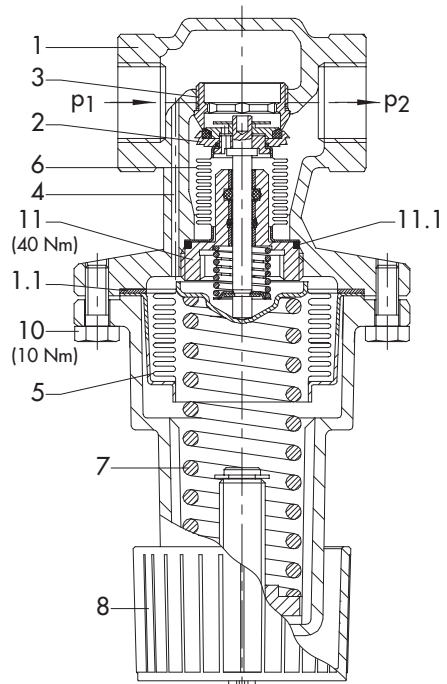

Type 44-6 B · Red brass body with screwed ends

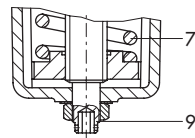

Set point screw

All stainless steel and spheroidal graphite iron versions (DN 40/50) as well as 8 to 20 bar set point range: hexagon socket screw with SW 3 or SW 5 (spheroidal graphite iron)

- 1 Valve body
- 1.1 Body gasket
- 2 Plug
- 3 Seat
- 4 Borehole in body for control pressure
- 5 Operating bellows
- 6 Balancing bellows (not with standard plug together with 0.2 to 2 bar set point range)
- 7 Set point spring
- 8 Set point adjuster
- 9 Set point adjusting screw
- 10 Screws
- 11 Sealing plug
- 11.1 Seal

Fig. 1: Functional diagram of Type 44-6 B

## 4.2 Strainer (filter)

Install a strainer (e.g. SAMSON Type 2 N/2 NI) upstream of the regulator (see Fig. 2).

- Select a strainer (mesh size) suitable for the process medium.
- The direction of flow must correspond to the arrow on the body.
- The filter element must be installed to hang downwards or sideways for applications with steam.
- Remember to leave enough space to remove the filter element.



**Note:**

*Check the strainer at regular intervals and clean it, if necessary.*

## 4.3 Shut-off valves

Install a hand-operated shut-off valve both upstream of the strainer and downstream of the regulator. This allows the plant to be shut down for cleaning and maintenance, and when the plant is not used for longer periods of time.

## 4.4 Pressure gauges

Install a pressure gauge both upstream and downstream of the regulator to monitor the pressures prevailing in the plant.

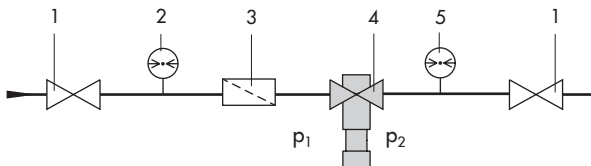

- 1 Shut-off valve
- 2 Upstream pressure gauge
- 3 Strainer (filter)
- 4 Type 44-6 B Excess Pressure Valve
- 6 Downstream pressure gauge

**Fig. 2:** *Sample application*



## 5 Operation

### 5.1 Start-up

See Fig. 1 on page 7.

Open the shut-off valves slowly preferably starting from the upstream pressure side. Avoid pressure surges.



#### NOTICE

*When performing the pressure test on the plant with an installed regulator, make sure the regulator is also open.*

*The pressure must not exceed the nominal pressure of the valve by 1.5 times nor the maximum permissible differential pressure  $\Delta p$  across the valve.*

---

### 5.2 Adjust the set point

See Fig. 1 on page 7.

Adjust the required set point by turning the set point adjuster (8) by hand or the set point adjusting screw (9).

- Turn the set point adjuster or adjusting screw clockwise (↻): to increase the pressure set point
- Turn counterclockwise (↺): to reduce the pressure set point.

Versions with bodies made of stainless steel and spheroidal graphite iron (DN 40 and 50) as well as 8 to 20 bar set point range:

Use an Allen key (SW 3 or SW 5 with spheroidal graphite iron body) to turn the set point adjusting screw (9). To do this, loosen

the lock nut, adjust the set point and retighten the lock nut.

The pressure gauge (Fig. 2) installed on the upstream side on site allows the adjusted set point to be monitored.

The set point range can be changed by exchanging the set point spring (7) (see section 6.3).

### 5.3 Decommissioning

Close first the shut-off valve on the upstream side of the valve and then on the downstream side of the valve.

## 6 Cleaning and maintenance

See Fig. 1 on page 7.

The regulators do not require any maintenance. Nevertheless, they are subject to natural wear, particularly at the seat and plug as well as the operating and balancing bellows.

As a result, it is necessary to check the proper functioning of the regulator at defined intervals depending on the operating conditions to detect and remove possible malfunctions.

External leakage can indicate that the operating bellows (see section 2.1) is defective. Check and replace it, if necessary.

Details on faults and how to remedy them can be found in Table 1.

In the simplest case, the functioning can be restored following the recommended action.



### **WARNING!**

*Before performing any work on the regulator, make sure the relevant plant section has been depressurized and, depending on the process medium, drained as well. We recommend removing the valve from the pipeline. When used at high temperatures, allow the plant section to cool down to ambient temperature. As valves are not free of cavities, remember that residual process medium might still be contained in the valve.*

## 6.1 Cleaning and exchanging the plug

See Fig. 1 on page 7.

To remove the stopper (11), use a socket wrench (SAMSON order no. 1280-3001).

1. Completely relieve the tension from the set point spring (7) by turning the set point adjuster (8/9) counterclockwise.
2. Unscrew the stopper (11). Pull out the balancing bellows (6) along with the plug (2) and plug stem.
3. Thoroughly clean the seat and plug.  
If the plug or balancing bellows is damaged, the entire unit (plug with bellows) must be replaced with a new one (the standard plug for 0.2 to 2 bar set point range does not come with a balancing bellows).
4. Renew the seal (11.1).
5. To reassemble, proceed in reverse order. Observe tightening torques specified in Fig. 1.

## 6.2 Replacing the operating bellows

See Fig. 1 on page 7.

1. Completely relieve the tension from the set point spring (7) by turning the set point adjuster (8/9) counterclockwise.



**Note:**

*The set point spring is still slightly pretensioned while the screws are being unscrewed.*

---

2. Evenly undo the screws (10).
3. Remove the bottom section with spring (7) and operating bellows (5).
4. Remove the operating bellows. Insert a new bellows.
5. Renew the body gasket (1.1).
6. To reassemble, proceed in reverse order. Observe tightening torques specified in Fig. 1.

## 6.3 Replacing the set point spring

See Fig. 1 on page 7.

The set point is located in the actuator housing. First remove the housing from the valve body to replace it.

1. Completely relieve the tension from the set point spring (7) by turning the set point adjuster (8/9) counterclockwise (↺) as far as it will go.



**Note:**

*The set point spring is still slightly pretensioned while the screws are being unscrewed.*

---

2. Evenly undo the screws (10).
3. Remove the bottom section with spring (7) and operating bellows (5).
4. Remove the spring and insert a new spring.
5. If necessary, renew the body gasket (1.1) to seal off the body.
6. To reassemble, proceed in reverse order. Observe tightening torques specified in Fig. 1.

Table 1: Troubleshooting

| Malfunction                                  | Possible reasons                                                                 | Recommended action                                                                                                                  |
|----------------------------------------------|----------------------------------------------------------------------------------|-------------------------------------------------------------------------------------------------------------------------------------|
| Pressure exceeds the adjusted set point.     | Insufficient pressure pulses on the operating bellows.                           | Clean the control line and the screw joint.                                                                                         |
|                                              | Special version with external control line · Pressure tapped at the wrong place. | Reconnect control lines at a different place · Do not tap pressure at pipe bends or necks.                                          |
|                                              | Seat and plug worn down by deposits or foreign particles.                        | Replace damaged parts.                                                                                                              |
|                                              | Foreign particles blocking the plug                                              | Remove foreign particles<br>Replace any damaged parts.                                                                              |
|                                              | Valve installed against the flow.                                                | Check direction of flow · Install the valve so that the direction of flow matches the direction indicated by the arrow on the body. |
| Pressure drops below the adjusted set point. | Foreign particles blocking the plug                                              | Remove foreign particles<br>Replace any damaged parts.                                                                              |
| Jerky control response.                      | Increased friction, e.g. due to foreign particles between seat and plug.         | Remove foreign particles<br>Replace any damaged parts.                                                                              |
| Slow control response.                       | Control line blocked by dirt and the flow through it is restricted.              | Clean the control line.                                                                                                             |
| Upstream pressure fluctuates                 | Valve too large                                                                  | Check valve sizing · Change $K_{VS}/C_V$ coefficient, if necessary, or install a different sized regulator.                         |
|                                              | Special version with external control line · Pressure tapped at the wrong place. | Reconnect control lines at a different place · Do not tap pressure at pipe bends or necks.                                          |
| Loud noises.                                 | High flow velocity, cavitation.                                                  | Check valve sizing · Install larger regulator, if necessary.                                                                        |

Exceptional operating and installation conditions can lead to changed situations that may affect the control response and lead to malfunctions. In such cases, check the installation conditions, process medium, temperature and pressure conditions. A thorough analysis may often require the on-site assistance of SAMSON after-sales service (see section 8).

## 7 Nameplate

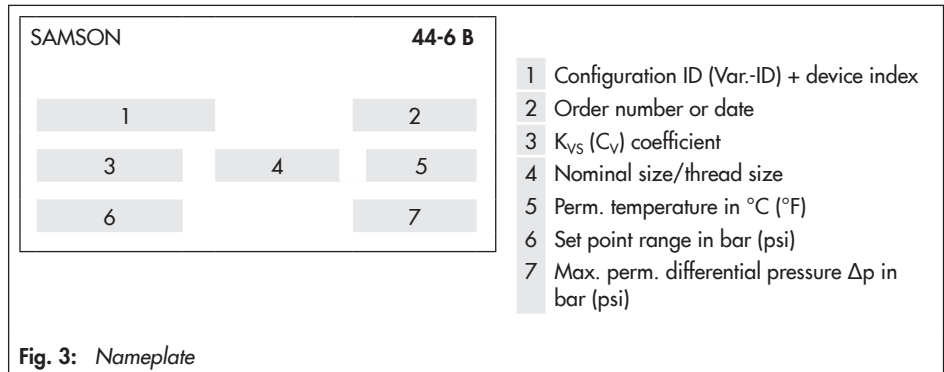

## 8 After-sales service

Contact SAMSON's After-sales Service department for support concerning maintenance or repair work or when malfunctions or defects arise.

### E-mail

You can reach the After-sales Service Department at [aftersaleservice@samson](mailto:aftersaleservice@samson).

### Addresses of SAMSON AG and its subsidiaries

The addresses of SAMSON AG, its subsidiaries, representatives, and service facilities worldwide can be found on the SAMSON website (▶ [www.samson.de](http://www.samson.de)) in all SAMSON product catalogs or on the back of these Mounting and Operating Instructions.

To assist diagnosis and in case of an unclear mounting situation, specify the following details (so far as possible):

- Type and nominal size/thread size of the valve (see section 7)
- Configuration ID (Var.-ID) + device index (see section 7)
- Upstream pressure  $p_1$  and downstream pressure  $p_2$
- Temperature and process medium
- Min. and max. flow rate
- Is a strainer installed?
- Installation drawing showing the exact location of the regulator and all the additionally installed components (shut-off valves, pressure gauge, etc.)

## 9 Technical data

**Table 2:** Technical data · All pressures in bar (gauge)

| Valve                                       |                                           | Type 44-6 B Excess Pressure Valve                                                |
|---------------------------------------------|-------------------------------------------|----------------------------------------------------------------------------------|
| Nominal pressure                            |                                           | PN 25                                                                            |
| Connection                                  | Stainless steel/red brass body            | Female thread G ½, G ¾, G 1                                                      |
|                                             | Stainless steel housing                   | Flanges DN 15 and 25                                                             |
|                                             | Spheroidal graphite iron body             | Flanges DN 15, 25, 40, and 50                                                    |
| Max. permissible temperature                | Liquids <sup>1)</sup>                     | 150 °C                                                                           |
|                                             | Air and non-flammable gases <sup>1)</sup> | 80 °C                                                                            |
|                                             | Steam <sup>1)</sup>                       | 200 °C                                                                           |
|                                             | Nitrogen <sup>1)</sup>                    | 200 °C                                                                           |
| Max. perm. differential pressure $\Delta p$ | G ½, G ¾, G 1   DN 15, DN 25              | 16 bar                                                                           |
|                                             | DN 40 and 50                              | 8 bar                                                                            |
| Leakage class according to IEC 60534-4      |                                           | ≤ 0.05 % of $K_{VS}$ coefficient                                                 |
| Compliance                                  |                                           | <b>CE · EAC</b>                                                                  |
| Set point range (continuously adjustable)   |                                           | 0.2 to 2 bar · 1 to 4 bar · 2 to 6 bar · 4 to 10 bar · 8 to 20 bar <sup>2)</sup> |
| Max. permissible ambient temperature        |                                           | 60 °C                                                                            |

<sup>1)</sup> The maximum permissible temperature is limited to 60 °C with FDA compliance.

<sup>2)</sup> Set point range **not** for DN 40 and 50.

**Table 3:**  $K_{VS}$  coefficients and  $x_{FZ}$  values

| Type 44-6 B · Flanged valve body     |                             |                             |                 |                 |       |
|--------------------------------------|-----------------------------|-----------------------------|-----------------|-----------------|-------|
| Valve size                           |                             | DN 15                       | DN 25           | DN 40           | DN 50 |
| $K_{VS}$ coefficients                | Standard version            | 3.2 <sup>1)</sup>           | 5 <sup>1)</sup> | 16              | 20    |
|                                      | Special version, unbalanced | 0.4 · 1 <sup>1)</sup> · 2.5 |                 | –               |       |
| $x_{FZ}$ values                      |                             | 0.60                        | 0.55            | 0.4             |       |
| Type 44-6 B · Body with screwed ends |                             |                             |                 |                 |       |
| Connection size                      |                             | G ½                         | G ¾             | G 1             |       |
| $K_{VS}$ coefficients                | Standard version            | 3.2 <sup>1)</sup>           | 4 <sup>1)</sup> | 5 <sup>1)</sup> |       |
|                                      | Special version, unbalanced | 0.4 · 1 <sup>1)</sup> · 2.5 |                 |                 |       |
| $x_{FZ}$ values                      |                             | 0.60                        | 0.60            | 0.55            |       |

<sup>1)</sup> Also available as special version for regulators with stainless steel body and FKM (FPM) soft seal.

## 10 Dimensions and weights

**Table 4:** *Dimensions and weights* · Regulators with flanged valve body

Spheroidal graphite iron EN-GJS-400-18-LT · Stainless steel 1.4408

| Valve size      | DN 15  | DN 25  | DN 40  | DN 50  |
|-----------------|--------|--------|--------|--------|
| Length L        | 130 mm | 160 mm | 200 mm | 230 mm |
| Height H1       | 155 mm | 155 mm | 245 mm | 245 mm |
| Height H2       | –      | –      | 95 mm  | 95 mm  |
| Weight, approx. | 2.6 kg | 4.2 kg | 7 kg   | 8 kg   |

### Dimensions of the regulators with flanged valve body

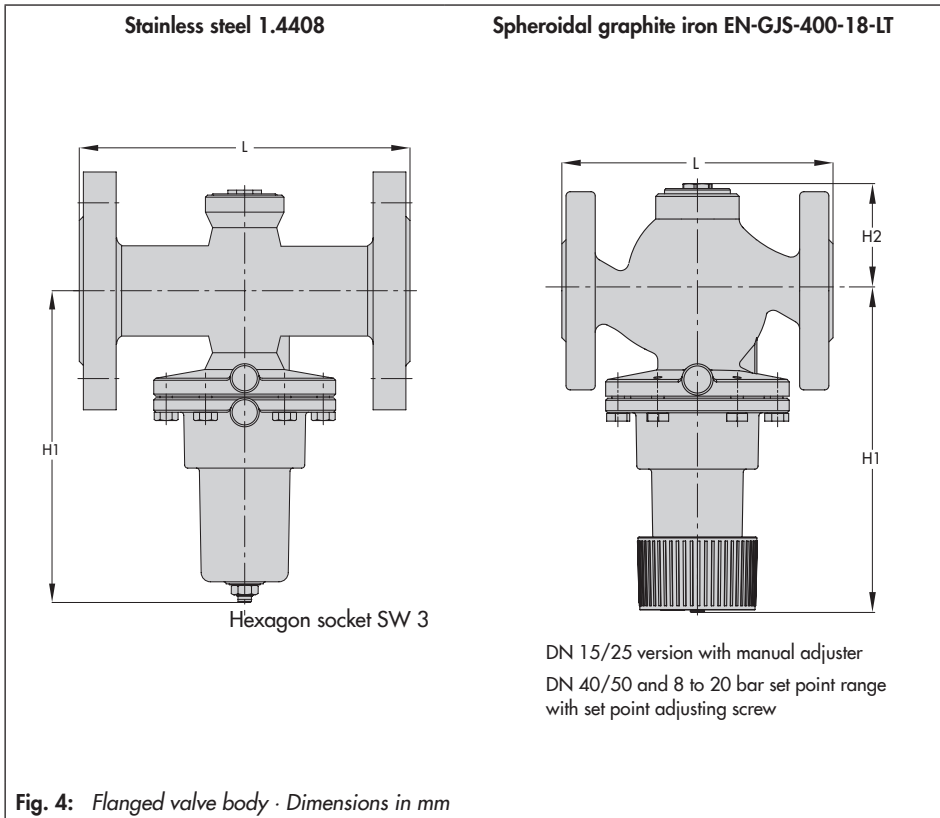

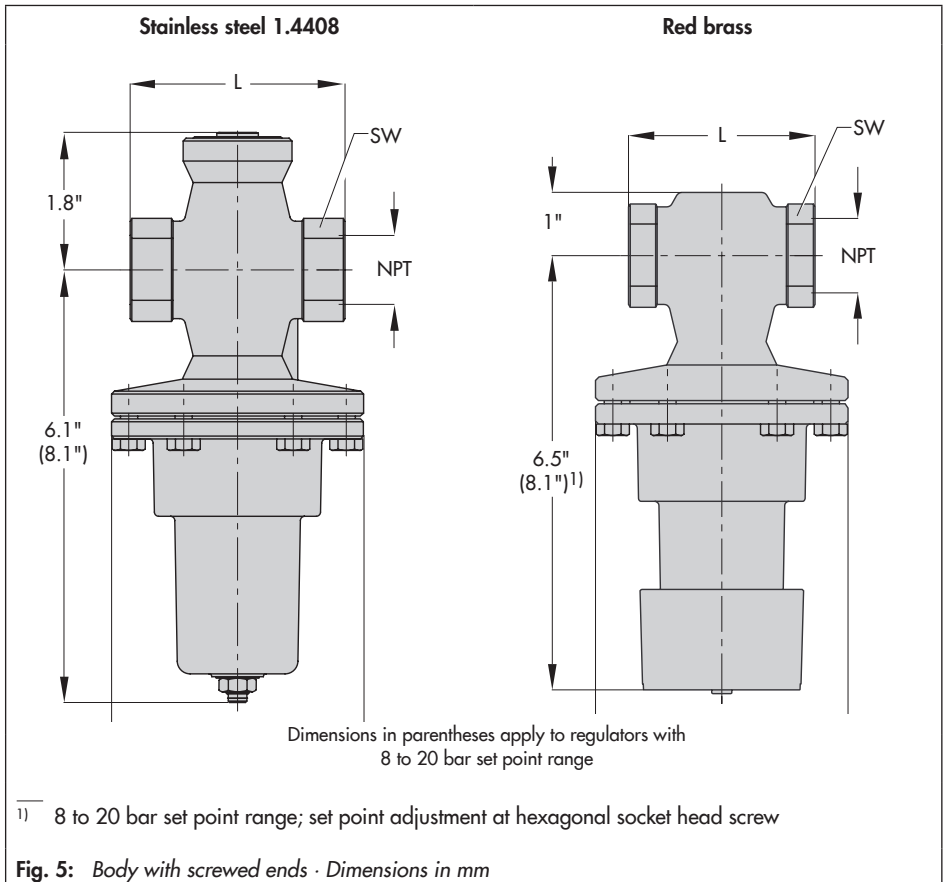

**Table 5:** *Dimensions and weights* · Regulators with body with screwed ends

**Red brass · Stainless steel 1.4408**

| Connection size       | G ½    | G ¾    | G 1    |
|-----------------------|--------|--------|--------|
| Female thread G       | ½"     | ¾"     | 1"     |
| Length L              | 65 mm  | 75 mm  | 90 mm  |
| Width across flats SW | 34 mm  | 34 mm  | 46 mm  |
| Weight, approx.       | 1.0 kg | 1.1 kg | 1.5 kg |

**Dimensions of the regulators with body with screwed ends**









SAMSON AG · MESS- UND REGELTECHNIK  
Weismüllerstraße 3 · 60314 Frankfurt am Main, Germany  
Phone: +49 69 4009-0 · Fax: +49 69 4009-1507  
samson@samson.de · www.samson.de

**EB 2626-2 EN**

2016-11-29 · English