

Pressure Reducing Valve Type 44-9

Safety Shut-off Valve (SSV) with Pressure Reducing Valve



Fig. 1 · Type 44-9

Mounting and Operating Instructions

EB 2630 EN

Edition December 2005



Contents	Page
1	Design and principle of operation 4
2	Installation 6
2.1	Mounting position 6
2.2	Strainer 6
2.3	Additional mounting instructions 6
3	Operation 6
3.1	Start-up 6
3.2	Set point adjustment 6
3.3	Decommissioning. 6
4	Maintenance 7
4.1	Cleaning or replacing the plug 7
4.2	Replacing the diaphragm 8
5	Description of nameplate 8
6	Customer inquiries 8
7	Dimensions and weights 9

Note!

Non-electric actuators and control valves do not have their own potential ignition source according to the risk assessment stipulated in EN 13463-1: 2001, section 5.2, even in the rare incident of an operating fault. Therefore, they **do not** fall within the scope of Directive 94/9/EC.

For connection to the equipotential bonding system, observe the requirements specified in EN 60079-14: 1977 (VDE 0165 Part 1), section 6.3.



General safety instructions

- ▶ *The valve may only be mounted, started up or serviced by fully trained and qualified personnel, observing the accepted industry codes and practices. Make sure employees or third persons are not exposed to any danger. All safety instructions and warnings in these mounting and operating instructions, particularly those concerning assembly, start-up, and maintenance, must be observed.*
- ▶ *The regulator fulfils the requirements of the European Pressure Equipment Directive 97/23/EC. Valves with a CE marking have a declaration of conformity that includes information about the applied conformity assessment procedure. The declaration of conformity will be provided on request.*
- ▶ *For appropriate operation, make sure the regulator is only used in areas where the operating pressure and temperatures do not exceed the operating values that are based on the valve sizing data submitted in the order.*
- ▶ *The manufacturer does not assume any responsibility for damage caused by external forces or any other external influence!
Any hazards that could be caused in the regulator by the process medium, the operating pressure or by moving parts are to be prevented by means of the appropriate measures.*
- ▶ *Proper shipping and appropriate storage are assumed.*

Important!

- ▶ *When removing the control valve from the pipeline, make sure the relevant section of the plant has been depressurized and, depending on the process medium, drained as well.
If necessary, allow the valve to cool down or warm up to reach ambient temperature prior to starting any work on it.*
- ▶ *Make sure the control valve is frost protected when it is used to control freezing process media.*

1 Design and principle of operation

The pressure reducing valve with safety shut-off valve is designed particularly for district heating plants to regulate the heating water flow downstream of the valve to the adjusted set point and shut the flow off when a certain limit value is reached.

The control valve is closed when the pressure downstream of the valve increases and opened when the pressure decreases.

The pressure reducing valve consists of the valve body with balanced plug as well as of the actuator with the spring assembly and the operating and safety diaphragms acting independently of each other.

The medium enters the valve body in the direction indicated by the arrow on the body. It flows through the orifice between the seat (2) and plug (3) and leaves the valve at the opposite port with its pressure reduced. The downstream pressure acts on the operating diaphragm (6.1) over the control line (11) to be provided by the customer. This pressure is converted into a positioning force, which is balanced by the force of the spring assembly (8).

When the pressure set point is exceeded, e.g. due to a ruptured operating diaphragm (6.1), the safety diaphragm (6.2) closes the valve. This state is indicated by the diaphragm rupture indicator (12).

Turning the set point adjuster (10) changes the spring force and thus the set point.

Typetesting

The pressure reducing valve used as safety shut-off valve (SSV) is typetested by TÜV (German technical surveillance association). Test marks are available on request.

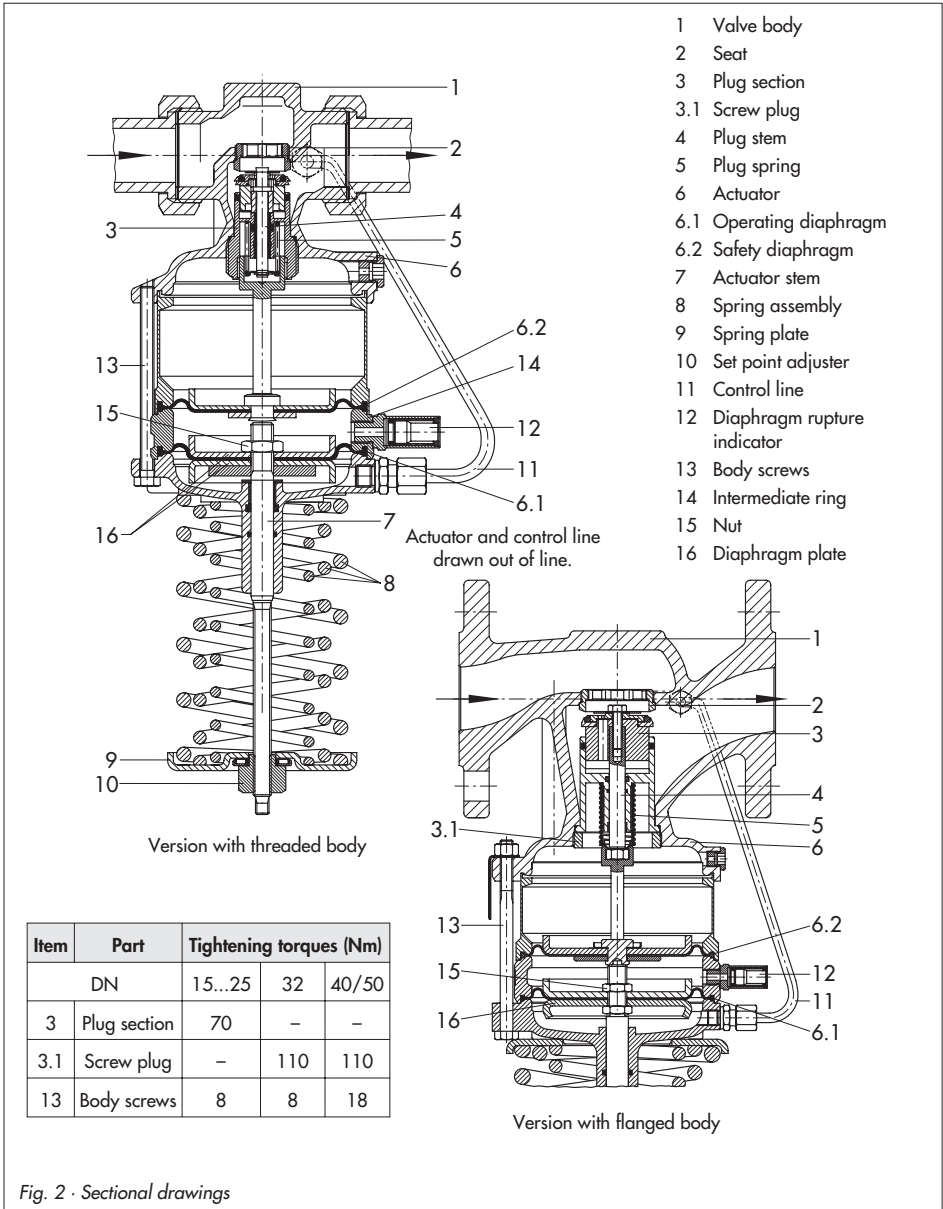

Fig. 2 · Sectional drawings

2 Installation

2.1 Mounting position

Install the valve in a horizontal pipeline with the actuator including spring assembly vertically suspended.

The direction of flow must correspond to the arrow on the body.

2.2 Strainer

Install a strainer (SAMSON Type 1NI) upstream of the safety shut-off valve to prevent sealing parts, weld spatter, and other impurities carried along by the process medium from impairing the proper functioning of the valve, above all the tight shut-off.

Install the strainer such that the direction of flow corresponds to the arrow on the body. The filter element must be vertically suspended. Remember to leave enough space to remove it.

2.3 Additional mounting instructions

We recommend to install hand-operated shut-off valves both upstream of the strainer and downstream of the valve to be able to shut down the plant for cleaning and maintenance. In addition, this relieves the operating diaphragms when the plant is not used for longer periods of time.

To monitor the pressures in the plant, install pressure gauges both upstream and downstream of the valve.

3 Operation

3.1 Start-up

Allow the plant to fill up slowly on start-up. First open the shut-off valve downstream, then the one upstream of the pressure reducing valve.

When pressure-testing the pipelines with the valve installed, make sure the diaphragm actuator is not damaged by the test pressure (max. perm. differential pressure Δp).

3.2 Set point adjustment

Adjust the set point by tensioning the spring assembly (8), monitoring the downstream pressure gauge:

- ▶ Turn set point adjuster (10) clockwise to increase the set point pressure and counterclockwise to reduce it.

3.3 Decommissioning

Close both shut-off valves: first the one upstream, then the one downstream of the valve.

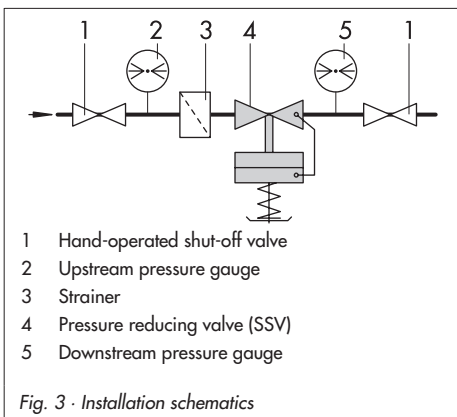

4 Maintenance

The control valve is subject to natural wear. Depending on the operating conditions, it must be checked at regular intervals.



Caution!

Remove the valve from the pipeline when working on it. Make sure the relevant section of the plant has been depressurized and, depending on the medium, drained as well. For high medium temperatures, allow the section of the plant to cool down to reach ambient temperature before you start.

If the downstream pressure increases when all consumers are switched off, the valve does not close tightly. This may happen when the tight shut-off is impaired by either dirt or natural wear on the seat and plug.

In case the lower operating diaphragm (6.1) fails, the pressure in the space between the diaphragms increases and causes the valve to close. At the same time, a red marking becomes visible at the diaphragm rupture indicator (12) when the pressure has reached approx. 1.5 bar.

Replace the defective diaphragm (6.1).

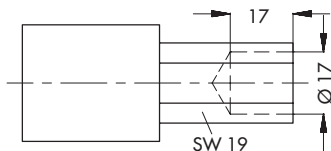

Fig. 4 · Socket wrench

If leaks occur at the actuator stem, disassemble the actuator as described in section 4.2. Make sure to check the actuator stem for ridges or score marks and replace the O-rings in the actuator lid.

4.1 Cleaning or replacing the plug

1. Remove valve from the pipeline. Unscrew control line (11) and remove spring assembly (8) with a suitable tool, e.g. SAMSON's spring removing clamp (order no. 9129-2747).



Caution!

The spring assembly (8) is pretensioned up to 180 mm with forces of almost 4000 N.

2. Unscrew body screws (13) and remove actuator with intermediate ring (14). **For sizes DN 15 to 25**, remove guide nipple of the plug section (3) using a socket wrench (order no. 1280-3001). This wrench can also be made, for example, from a GEDORE screwdriver bit (IN 19-19) by boring a 17 mm hole (Ø 17) into the 19 mm hexagon bit as illustrated in Fig. 4.

For sizes DN 32 to 50, unscrew screw plug (3.1) and remove plug section.

3. Thoroughly clean the seat and plug section. Remove any dirt or blockages from the control line (11). Replace entire plug section in case the plug is damaged.

4. Check seat ring (2). In case the ring is damaged, unscrew and replace it.
5. For reassembly, proceed in reverse order, observing the tightening torques specified in the table in Fig. 2.

4.2 Replacing the diaphragm

1. Remove valve from the pipeline.
2. Unscrew control line (11) and remove spring assembly (8) with a suitable tool, e.g. SAMSON's spring removing clamp (order no. 9129-2747).



Caution!

The spring assembly (8) is pretensioned up to 180 mm with forces of almost 4000 N.

3. Unscrew body screws (13) and remove actuator with intermediate ring (14).
4. Unscrew nut (15) from the actuator stem and remove diaphragm plate (16).
5. Replace diaphragm(s).
6. For reassembly, proceed in reverse order, observing the tightening torques specified in the table in Fig. 2.

5 Description of nameplate

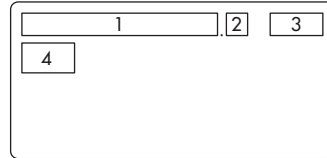

- 1 Model number
- 2 Modification index
- 3 Date of manufacture
- 4 Type designation

In the other fields:

Nominal pressure PN or ANSI Class
K_{VS} or Cv value
Max. permissible temperature in °C or °F
Set point range
Differential pressure in bar or psi
Max. perm. differential pressure Δp

Fig. 5 · Nameplate

6 Customer inquiries

Include the following details when making inquiries:

- ▶ Type and size of the valve
- ▶ Order and model numbers
- ▶ Pressures upstream and downstream of the valve
- ▶ Temperature and process medium
- ▶ Min. and max. flow rates
- ▶ Has a strainer been installed?
- ▶ Installation drawing

7 Dimensions and weights

Nominal size	DN	15	20	25	32	40	50
Pipe \varnothing d		21.3	26.8	33.7	42	48	60
Connection R		G 3/4	G 1	G 1 1/4	G 1 3/4	G 2	G 2 1/2
Width across flats SW		30	36	46	59	65	82
Length L		65	70	75	100	110	130
L1 with welding ends		210	234	244	268	294	330
Height H		235 (273) ¹⁾			393		
Weight, approx. kg		2.0	2.1	2.2	3.5	9.0	9.5
Special version with threaded ends (male thread)							
Length L2		129	144	159	180	196	228
Male thread A		G 1/2	G 3/4	G 1	G 1 1/4	G 1 1/2	G 2
Weight, approx. kg		2.0	2.1	2.2	3.5	9.0	9.5
Special version with flanges PN 16/25 or special version with flanged body (DN 32/40/50)							
Length L3		130	150	160	180	200	230
Weight, approx. kg	Threaded	3.5	4.1	4.7	7	13	14.5
	Flanged	-	-	-	6.5	11	12.5

¹⁾ Set point range 6 to 11 bar

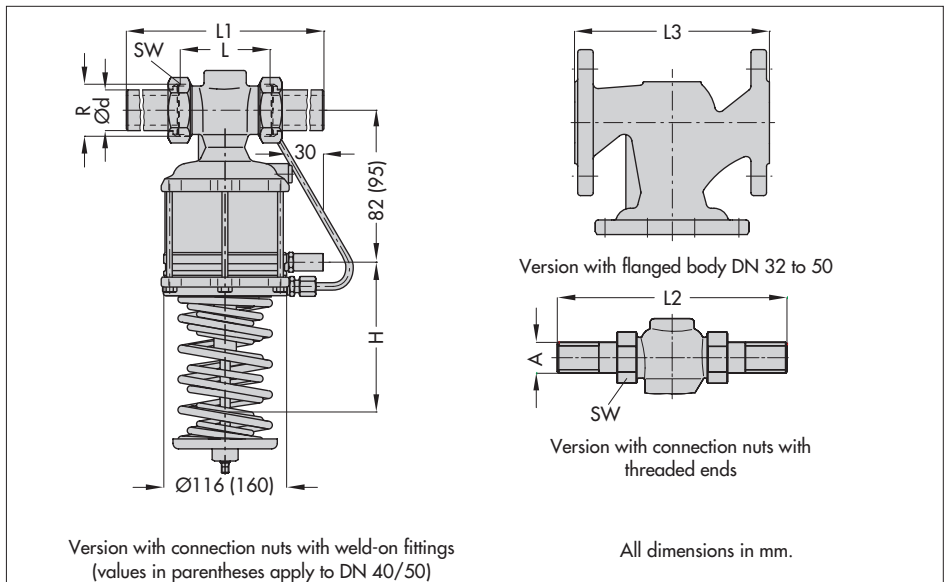



SAMSON AG · MESS- UND REGELTECHNIK
Weismüllerstraße 3 · 60314 Frankfurt am Main · Germany
Phone: +49 69 4009-0 · Fax: +49 69 4009-1507
Internet: <http://www.samson.de>

EB 2630 EN

S/Z 2005-12