

# Excess Pressure Valve Type 44-4

## Safety Excess Pressure Valve (SEV)

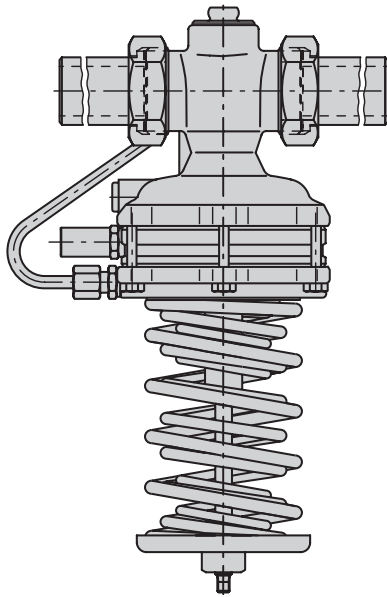

Fig. 1 · Type 44-4

## Mounting and Operating Instructions

**EB 2632 EN**

Edition March 2004



Contents	Page
<b>1</b>	<b>Design and principle of operation</b> . . . . . 4
<b>2</b>	<b>Installation</b> . . . . . 6
2.1	Mounting position . . . . . 6
2.2	Additional mounting instructions . . . . . 6
<b>3</b>	<b>Operation</b> . . . . . 6
3.1	Start-up . . . . . 6
3.2	Set point adjustment . . . . . 6
3.3	Decommissioning. . . . . 6
<b>4</b>	<b>Maintenance</b> . . . . . 7
4.1	Cleaning or replacing the plug . . . . . 7
4.2	Replacing the diaphragm . . . . . 8
<b>5</b>	<b>Description of nameplate</b> . . . . . 8
<b>6</b>	<b>Customer inquiries</b> . . . . . 8
<b>7</b>	<b>Dimensions and weights</b> . . . . . 9



### General safety instructions

- ▶ The valve may only be mounted, started up or serviced by fully trained and qualified personnel, observing the accepted industry codes and practices. Make sure employees or third persons are not exposed to any danger. All safety instructions and warnings in these mounting and operating instructions, particularly those concerning assembly, start-up, and maintenance, must be observed.
- ▶ The valve fulfils the requirements of the European Pressure Equipment Directive 97/23/EC. Valves with a CE marking have a declaration of conformity that includes information about the applied conformity assessment procedure. The declaration can be viewed and downloaded on the Internet at <http://www.samson.de>.
- ▶ For appropriate operation, make sure the valve is only used in areas where the operating pressure and temperatures do not exceed the operating values that are based on the valve sizing data submitted in the order.
- ▶ The manufacturer does not assume any responsibility for damage caused by external forces or any other external influence! Any hazards that could be caused in the valve by the process medium, the operating pressure or by moving parts are to be prevented by means of the appropriate measures.
- ▶ Proper shipping and appropriate storage are assumed.

### Important!

- ▶ When removing the regulator from the pipeline, make sure the relevant section of the plant has been depressurized and, depending on the process medium, drained as well. If necessary, allow the valve to cool down or warm up to reach ambient temperature prior to starting any work on it.
- ▶ Make sure the valve is frost protected when it is used to control freezing process media.

### Note!

Non-electrical valves whose valve bodies are not lined with an **insulating material coating** do not have their own potential ignition source according to the risk assessment stipulated in EN 13463-1: 2001, paragraph 5.2, even in the rare incident of an operating fault. Therefore, such valve versions do **not** fall within the scope of Directive 94/9/EC.

## 1 Design and principle of operation

The safety excess pressure valve is designed particularly for district heating plants to regulate the heating water flow upstream of the valve to the adjusted set point and open the valve when a certain limit value is reached. The valve is opened when the pressure upstream of the valve increases and closes as the pressure decreases.

The excess pressure valve consists of the valve body with balanced plug as well as of the actuator with the spring assembly and the operating and safety diaphragms acting independently of each other.

The medium enters the valve body in the direction indicated by the arrow on the body. It flows between the seat (2) and plug (3.1). The position of the valve plug determines the flow rate and, as a result, the pressure upstream of the valve.

The upstream pressure to be controlled (excess pressure) is transferred over the attached control line (11) and acts on the operating diaphragm (6.1). This pressure is converted into a positioning force, which is balanced by the force of the spring assembly (8).

In the event that the operating diaphragm (6.1) ruptures, the safety diaphragm (6.2) takes over its function and opens the valve. This state is indicated by the diaphragm rupture indicator (12) or an inspection bore in the actuator.

Turning the set point adjuster (10) changes the spring force and, as a result, the set point.

---

### **Type examination**

*The safety excess pressure valve (SEV) is type tested by the German technical surveillance association TÜV (register number available on request).*

---

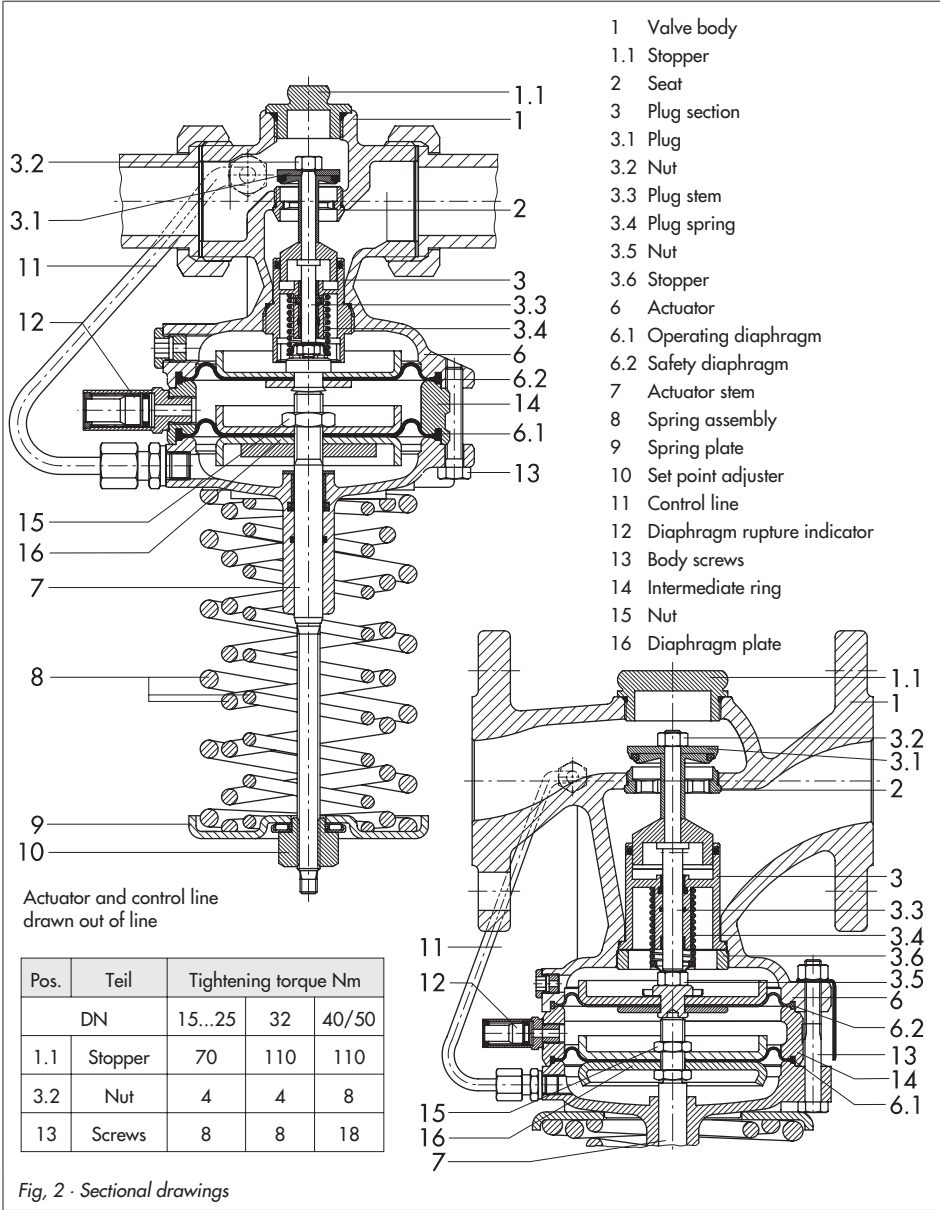

Fig. 2 · Sectional drawings

## 2 Installation

### 2.1 Mounting position

Install the valve in a horizontal pipeline with the actuator including spring assembly suspended downward.

The direction of flow must correspond to the arrow on the body.

Never install a strainer upstream of the safety excess pressure valve.

The outlet of the pipeline to the safety excess pressure valve must be located either at the side of the main pipe or at the top of the main pipe to reduce the amount of dirt carried along by the process medium.

### 2.2 Additional mounting instructions

To monitor the pressures in the plant, we recommend installing a pressure gauge both upstream and downstream of the valve.

## 3 Operation

### 3.1 Start-up

Allow the plant to fill up slowly on start-up. First open the shut-off valve downstream, then the one upstream of the excess pressure valve.

When pressure-testing the pipelines with the valve installed, make sure the diaphragm actuator is not damaged by the test pressure (max. 14 bar).

### 3.2 Set point adjustment

Adjust the set point by tensioning the spring assembly (8), monitoring the upstream pressure gauge:

- ▶ Turn set point adjuster (10) clockwise to increase the upstream pressure and counterclockwise to reduce it.

### 3.3 Decommissioning

Close both shut-off valves: first the one upstream, then the one downstream of the valve.

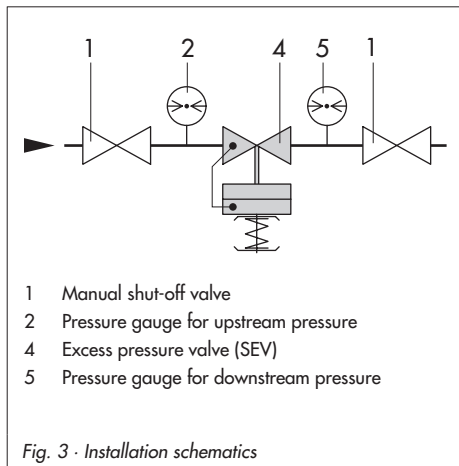

## 4 Maintenance

The valve is subject to natural wear. Depending on the operating conditions, it must be checked at regular intervals.



### Caution!

Remove the valve from the pipeline when working on it. Make sure the relevant section of the plant has been depressurized and, depending on the medium, drained as well. For high medium temperatures, allow the section of the plant to cool down to reach ambient temperature before you start.

If the upstream pressure drops considerably, the valve does not close tightly. This may happen when the tight shut-off is impaired by either dirt or natural wear on the seat and plug.

In the event that the operating diaphragm (6.1) fails, the pressure to be controlled drops considerably and the valve opens, i.e. moves to its fail-safe position. At the same time, a red marking (point of response at approx. 1.5 bar) becomes visible at the diaphragm rupture indicator (12), or

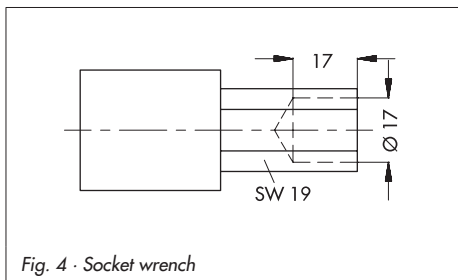

Fig. 4 - Socket wrench

medium leaks from the inspection bore at the actuator.

Replace the defective diaphragm (6.1).

If leaks occur at the actuator stem, disassemble the actuator as described in section 4.2. Make sure to check the actuator stem for ridges or score marks and replace the O-rings in the actuator lid.

### 4.1 Cleaning or replacing the plug

1. Remove valve from the pipeline. Unscrew control line (11) and remove spring assembly (8) with a suitable tool, e.g. SAMSON's spring removing clamp (order no. 9129-2747).



### Caution!

The spring assembly (8) is pretensioned by up to 180 mm with forces of almost 4000 N.

2. Unscrew stopper (1.1).
3. Unscrew body screws (13) and remove actuator with intermediate ring (14).
4. Unscrew nut (3.2) and remove plug (3.1) from the plug stem.
5. **In sizes DN 15 to 25**, unscrew and pull out the guide nipple of the plug section (3) using a socket wrench (order no. 1280-3001). This wrench can also be made, for example, from a GEDORE screwdriver bit (IN 19-19) by drilling a 17 mm hole ( $\varnothing 17$ ) into the 19 mm hexagon bit as illustrated in Fig. 4.

In sizes DN 32 to 50, unscrew stopper (3.1) and then pull out plug section (3).

6. Thoroughly clean the seat and plug section. Remove any dirt or blockages from the control line (11).

Check the seat ring (2) for damage and, if necessary, unscrew it and replace it with a new one.

7. For reassembly, proceed in reverse order, observing the tightening torques specified in the table in Fig. 2.

### 4.2 Replacing the diaphragm

1. Remove valve from the pipeline.
2. Unscrew control line (11) and remove spring assembly (8) with a suitable tool, e.g. SAMSON's spring removing clamp (order no. 9129-2747).



#### Caution!

The spring assembly (8) is pretensioned by up to 180 mm with forces of almost 4000 N.

3. Unscrew body screws (13) and remove actuator with intermediate ring (14).
4. Unscrew nut (15) from the actuator stem and remove diaphragm plate (16).
5. Replace diaphragm(s).
6. For reassembly, proceed in reverse order, observing the tightening torques specified in the table in Fig. 2.

## 5 Description of nameplate

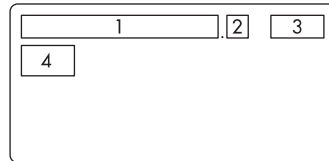

- 1 Model number
- 2 Modification index
- 3 Date of manufacture
- 4 Type designation  
In the other fields:  
Nominal pressure PN or ANSI Class  
 $K_v$  or  $c_v$  value  
Max. permissible temperature °C or °F  
Set point range  
Differential pressure in bar or psi  
Max. perm. differential pressure  $\Delta p$

Fig. 5 · Nameplate

## 6 Customer inquiries

Include the following details when making inquiries:

- ▶ Type and size of the valve
- ▶ Order and model numbers
- ▶ Pressures upstream and downstream of the valve
- ▶ Temperature and process medium
- ▶ Min. and max. flow rates
- ▶ Has a strainer been installed?
- ▶ Installation drawing

## 7 Dimensions and weights

Nominal size	DN	15	20	25	32	40	50
Pipe $\varnothing$ d		21.3	26.8	33.7	42	48	60
Connection R		G 3/4	G 1	G 1 1/4	G 1 3/4	G 2	G 2 1/2
Width across flats SW		30	36	46	59	65	82
Length L		65	70	75	100	110	130
L1 with welding ends		210	234	244	268	294	330
Height H		247 (272) <sup>1)</sup>			267 (292) <sup>1)</sup>		409.5
Weight, approx. kg		2.0	2.1	2.2	3.5	9.0	9.5
Special version with threaded ends (male thread)							
Length L2		129	144	159	180	196	228
Male thread A		G 1/2	G 3/4	G 1	G 1 1/4	G 1 1/2	G 2
Weight, approx. kg		2.0	2.1	2.2	3.5	9.0	9.5
Version with flanges PN 16/25 or special version with flanged body (DN 32/40/50)							
Length L3		130	150	160	180	200	230
Weight, approx. kg	Red brass	3.5	4.1	4.7	7	13	14.5
	GGG	-	-	-	7	13	14.5

<sup>1)</sup> Set point range 6.6 to 11 bar

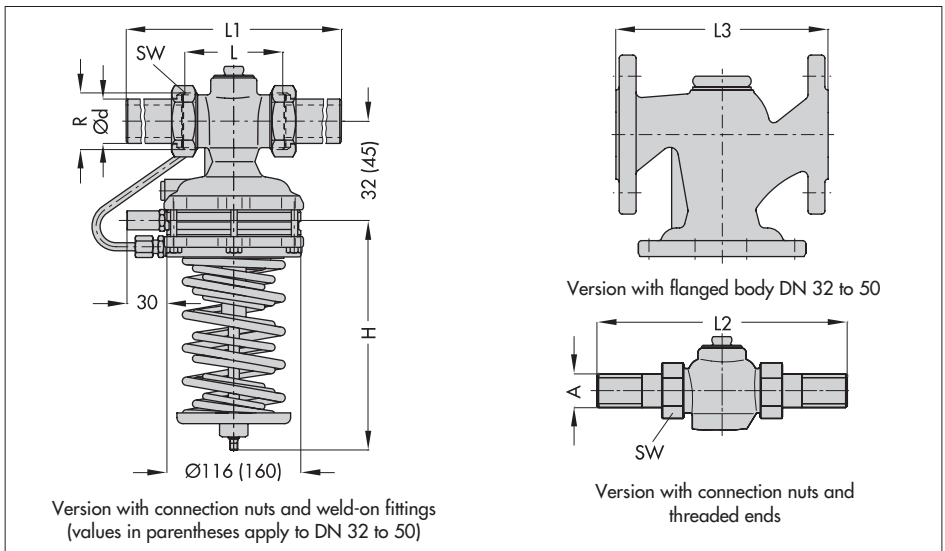



SAMSON AG · MESS- UND REGELTECHNIK  
Weismüllerstraße 3 · 60314 Frankfurt am Main · Germany  
Phone: +49 69 4009-0 · Fax: +49 69 4009-1507  
Internet: <http://www.samson.de>

**EB 2632 EN**

S/Z 2004-05