

Type 42-36 E

Pressure-independent Control Valve (PICV)

With Type 5824/5825, Type 3374, and
Type 3274 Electric Actuator

SAMSON



Type 42-36 E with Type 5825 Actuator



Type 42-36 E with Type 3374 Actuator

Mounting and Operating Instructions

EB 3018 EN

Edition August 2015



Definition of signal words



DANGER!

Hazardous situations which, if not avoided, will result in death or serious injury



WARNING!

Hazardous situations which, if not avoided, could result in death or serious injury



NOTICE

Property damage message or malfunction



Note:

Additional information



Tip:

Recommended action

1	General safety instructions	4
2	Process medium and scope of application	5
2.1	Transportation and storage	5
3	Design and principle of operation	6
4	Installation	6
4.1	Mounting position	6
4.2	Notes on installation	7
4.2.1	Insulation	7
4.3	Additional installed components	7
4.3.1	Strainer	7
4.3.2	Shut-off valves	7
4.3.3	Pressure gauges	7
5	Start-up	8
5.1	Electrical connection.....	8
5.2	Set point adjustment.....	9
5.2.1	DN 15 to 50 with Type 5824 or Type 5825 Actuator	10
5.2.2	DN 65 to 100 with Type 3374 or Type 5824-30 Actuator.....	12
5.2.3	DN 125 to 250 with Type 3274 or Type 3374 Actuator.....	14
6	Dimensions and weights	18
7	Technical data	22
8	After-sales service	23



1 General safety instructions

- The device must be mounted, started up, or serviced by fully trained and qualified personnel only; the accepted industry codes and practices are to be observed. Make sure employees or third persons are not exposed to any danger.
- All safety instructions and warnings given in these mounting and operating instructions, particularly those concerning installation, start-up, and maintenance, must be strictly observed.
- According to these mounting and operating instructions, trained personnel refers to individuals who are able to judge the work they are assigned to and recognize possible dangers due to their specialized training, their knowledge and experience as well as their knowledge of the applicable standards.
- The devices comply with the requirements of the European Pressure Equipment Directive 2014/68/EU. Devices with a CE marking have an EC declaration of conformity, which includes information about the applied conformity assessment procedure. This EC declaration of conformity can be provided on request.
- To ensure appropriate use, only use the device in applications where the operating pressure and temperatures do not exceed the specifications used for sizing the device at the ordering stage.
- The manufacturer does not assume any responsibility for damage caused by external forces or any other external factors.
- Any hazards that could be caused in the regulator by the process medium, operating pressure or by moving parts are to be prevented by taking appropriate precautions.
- Proper transport, storage, installation, operation, and maintenance are assumed.



Testing according to DIN EN

The Types 5825, 3374 and 3274 Electric Actuators with fail-safe action are tested by the German technical surveillance association TÜV according to DIN EN 14597 in combination with the Type 2423 Valve. The register number is available on request.

2 Process medium and scope of application

Self-operated regulators for flow rate control in district heating systems or large heating or cooling networks. Combined with an electric actuator used to transmit the control signal of an electric controller.

Valves in nominal sizes DN 15 to 250 · Nominal pressure PN 16 to 40 · Suitable for liquids from 5 to 150 °C

2.1 Transportation and storage

The regulator must be carefully handled, transported, and stored. Protect the regulator against adverse influences, such as dirt, moisture or frost, during storage and transportation.

**Note:**

Before installing the regulator, tighten the blanking plug(s) at the side in the valve body using a suitable box wrench.

Torque: 50 Nm for G 1/4, 70 Nm for G 3/8

When regulators are too heavy to be lifted by hand, fasten the lifting sling to a suitable place on the valve body.

**WARNING!**

Incorrectly attached lifting slings or supports.

Risk of injury and property damage due to valve falling.

Securely fasten slings or supports to the valve body and secure against slipping.

3 Design and principle of operation

The device combinations consist of the **Type 42-36** Pressure-independent Control Valve (PICV) and a **Type 5824**, **Type 5825**, or **Type 3374** Electric Actuator or **Type 3274** Electrohydraulic Actuator (depending on the nominal valve size).

The regulator closes when the flow rate or the output signal of the electric controller increases.

Version

Type 42-36 E: DN 15 to 250, consisting of a Type 2426 Diaphragm Actuator and a Type 2423 E Valve (balanced by a bellows or diaphragm) with restriction to adjust the flow rate set point. The regulator is installed in the flow or return flow pipe.

The valves are fitted with an adapter for connection of an electric actuator. It serves to apply the control signal (mostly a temperature signal) of an electric control device. The electric actuator adjusts the restriction and thus the flow set point.

The set point ranges for the flow rate listed (see Fig. 3, Fig. 5 and Fig. 6) are based on water with a differential pressure at the restriction $\Delta p_{\text{restriction}}$ of 0.2 or 0.5 bar.



Note:

Read the mounting and operating instructions for the basic regulators listed in Table 1.

Table 1: Technical information

Electric actuator	Mounting and operating instructions
Type 3274	▶ EB 8340
Type 5824/25	▶ EB 5824-1, ▶ EB 5824-2
Type 3374	▶ EB 8331-...
Regulator	Mounting and operating instructions
Type 42-36	▶ EB 3015

4 Installation

4.1 Mounting position

Install the regulators in horizontal pipelines. The direction of flow must match the arrow on the valve body.

The electric actuator must be mounted above the valve body.



NOTICE

Malfunction and damage due to adverse effects of weather conditions (temperature, humidity).

Do not install the regulator outdoors or in rooms prone to frost. If such a location cannot be avoided, protect the regulator against freezing up if the process medium flowing through the valve can freeze up. Either heat the regulator or remove it from the plant and completely drain the residual medium.

4.2 Notes on installation

4.2.1 Insulation

On insulating the valve (DN 15 to 50), do not insulate the actuator and the coupling nut as well. Additionally, make sure that the temperature, especially at the actuator stem, does not exceed the maximum permissible ambient temperature. If necessary, install an intermediate insulating piece (order no. 1990-1713). The insulating limit is in this case approx. 25 mm above the top of the valve body.

To insulate cold systems, we recommend first filling the plant. The regulator must not be insulated until the set point is adjusted and/or corrected.

- Start up the plant and adjust the set point. Shut down the plant again and let it heat up until the condensation water has dried off.
- Afterwards, insulate the regulator and pipes conveying the process medium using insulation material with a water vapor barrier. The electric actuator (for DN 15 to 50 with intermediate insulating piece 1990-1713, for DN 65 to 250 actuator with yoke) must remain freely accessible. The insulation thickness depends on the medium temperature and the ambient conditions. 50 mm is a typical thickness.

4.3 Additional installed components

4.3.1 Strainer

A strainer installed upstream in the flow pipe holds back any dirt or other foreign particles carried along by the medium. For example, the SAMSON Type 2 N/2 NI Strainer is suitable (see ► T 1015).

- The direction of flow must correspond to the arrow on the body.
- The filter element must be installed to hang downward.



Tip:

Remember to leave enough space to remove the filter element.

4.3.2 Shut-off valves

Install a hand-operated shut-off valve both upstream of the strainer and at the outlet of the return flow pipe. This allows the plant to be shut down for cleaning and maintenance, and when the plant is not used for longer periods of time.

4.3.3 Pressure gauges

Install a pressure gauge both upstream and downstream of the regulator to monitor the pressures prevailing in the plant.

5 Start-up

→ See Fig. 2 (page 11), Fig. 4 (page 13), Fig. 7 (page 17)

Do not start up the regulator until all parts have been mounted (e.g. valve, actuator, and control lines).

Before start-up, check to make sure that the actuator is connected correctly.

How to proceed:

- Slowly fill the plant with process medium with an open restriction (2.7) (∩: to open restriction).
- Open the shut-off valves preferably starting from the return flow pipe. Slowly open the valves in small steps waiting a few minutes in between.
- Vent the bellows housing of valves balanced by a bellows (DN 125 and larger) at the vent plug (8) located at the side.
- Open the control lines.
- Rinse out the pipeline at full flow rate for several minutes. Check the installed strainer (e.g. by measuring the pressure drop). Clean the strainer, if necessary.
- **Pressure test** · Make sure that the diaphragm actuator is not damaged by the test pressure. The pressure in the actuator must not exceed the maximum permissible pressure for the actuator. Shut off any externally mounted control lines.



Note:

The electric actuator with fail-safe action move to a defined position ("actuator stem extends" with closed restriction) in the de-energized state (e.g. upon power supply failure, when the electric connections of the actuator have not yet been made).

The actuator wiring must therefore be connected or the restriction must be opened using the manual override on filling the plant for the first time and performing a preliminary start-up. Refer to the relevant mounting and operating instructions (see Table 1 on page 6) for more details on the fail-safe action of the mounted actuator.

5.1 Electrical connection

The electric actuators are designed for use in electric power installations. For wiring and maintenance, observe the relevant safety regulations.



NOTICE

Property damage or malfunction by inadvertent reconnection of the electric actuator! Only use power interruption devices that are protected against unintentional reconnection of the power supply.

5.2 Set point adjustment

The flow rate can be adjusted either when the electric actuator is mounted on the valve or without a mounted electric actuator.

The flow rate set point is determined by the position of the restriction (2.7) on the valve.

Turn counterclockwise (↺):

- To open the restriction

Turn clockwise: (↻):

- To close the restriction

Refer to the relevant mounting and operating instructions (see Table 1 on page 6) for further possible settings of the electric actuator.

In addition to the details in the mounting and operating instructions of the basic device, adjust the flow rate as described in sections 5.2.1 to 5.2.3.

5.2.1 DN 15 to 50 with Type 5824 or Type 5825 Actuator

Adjustment without actuator · See Fig. 2 on page 11

1. Close the restriction (2.7). To proceed, loosen the locking screw (2.6) and turn the set point adjuster (2.3) clockwise as far as it will go.
2. Determine the turns required to achieve the desired flow rate from the adjustment diagrams (see Fig. 1 on page 10).
3. Based on a closed restriction, turn the set point adjuster counterclockwise to adjust the flow rate set point.

Flow rate set point ranges for water · Type 2423 E Regulator, balanced by a bellows

Set point ranges in m ³ /h with ...	DN 15	DN 20	DN 25	DN 32	DN 40	DN 50
Diff. pressure at restriction $\Delta p_{\text{restriction}} = 0.2$ bar	0.5 to 2	0.5 to 3	0.8 to 3.5	2 to 7	3 to 11	3 to 16
Diff. pressure at restriction $\Delta p_{\text{restriction}} = 0.5$ bar	0.8 to 3	0.8 to 4.5	1.2 to 5.3	3 to 9.5	4.5 to 16	4.5 to 24

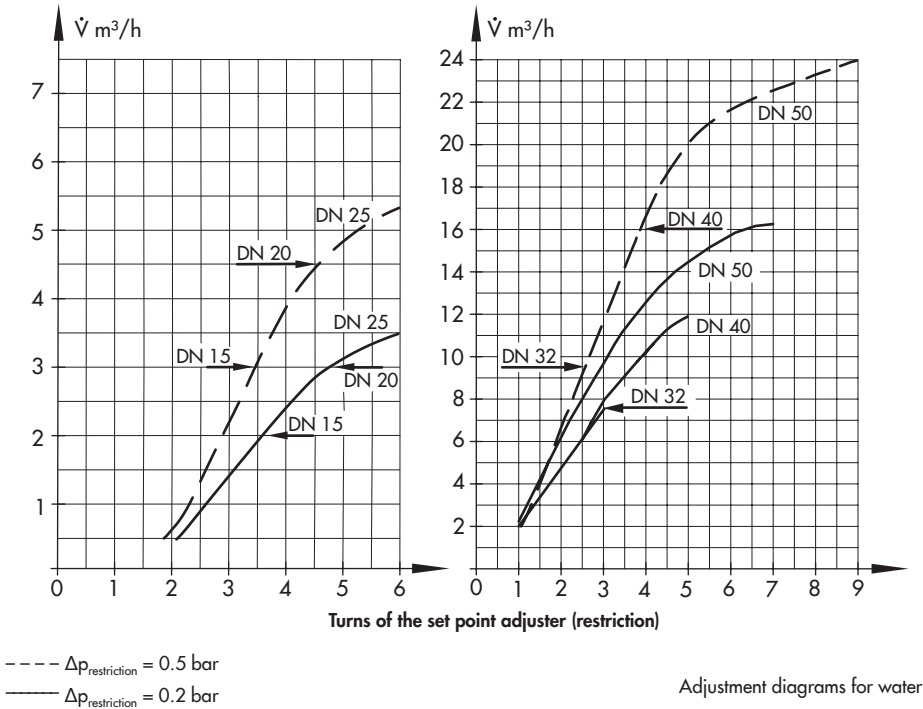

Fig. 1: Adjustment diagrams for Type 2423 E Regulator, balanced by a bellows, DN 15 to 50

4. Check the flow rate and correct it, if necessary. Secure this setting with the locking screw (2.6).
5. For a tension-free installation, place the actuator with retracted stem on the restriction connection and fasten tight using the coupling nut (tightening torque 20 Nm).

Adjustment with Type 5824/5825 Actuator

See Fig. 2

More details on the electric actuator in

► EB 5824-...

Type 5824 Actuator

1. Retract the actuator stem by turning the handwheel counterclockwise or by applying a corresponding control signal from the control device.
2. Continue as described for adjustment without actuator in steps 1 to 5.

Type 5825 Actuator

1. Switch the controller to the manual operating mode. Adjust the control signal so that the actuator stem retracts all the way and the spring mechanism is compressed.

If there is no control signal, the actuator can be adjusted using the manual override. For manual adjustment, remove the front cover. Insert a 4 mm hexagonal wrench into the red actuating shaft and turn it counterclockwise. Turn it only counterclockwise and only up to the point at which the torque switch in the actuator is activated.

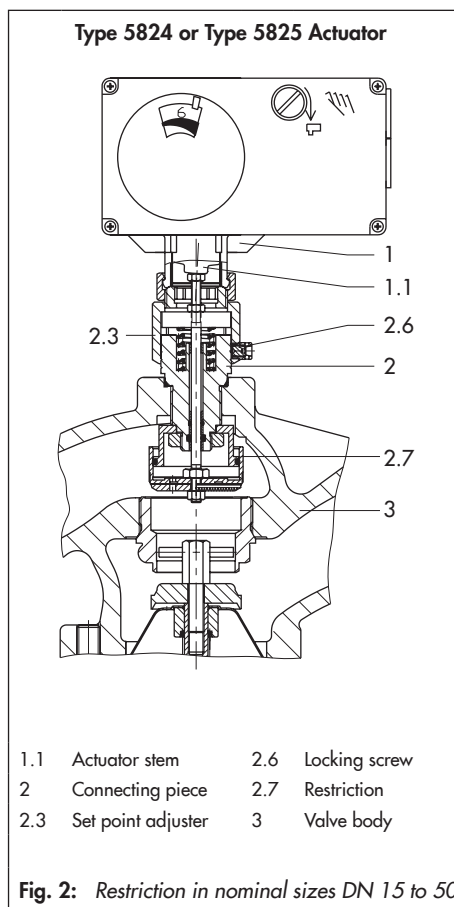

Once the magnet has been released, the spring mechanism pushes the actuator stem back to the fail-safe position.

2. Continue as described for adjustment without actuator in steps 1 to 5.

5.2.2 DN 65 to 100 with Type 3374 or Type 5824-30 Actuator

Adjustment without actuator · See Fig. 4 on page 13

1. Thread the lock nut (2.2) upwards on the threaded rod (2.1).

2. Close the restriction (2.7). To proceed, loosen the locking screw (2.6) and turn the set point adjuster (2.3) clockwise as far as it will go.
3. Determine the turns required to achieve the desired flow rate from the adjustment diagrams (see Fig. 3).

Flow rate set point ranges for water · Type 2423 E Regulator, balanced by a bellows or diaphragm

Set point ranges in m ³ /h with ...	DN 65	DN 80	DN 100
Diff. pressure at restriction $\Delta p_{\text{restriction}} = 0.2 \text{ bar}$	5 to 28	7 to 35 ¹⁾	10 to 63
Diff. pressure at restriction $\Delta p_{\text{restriction}} = 0.5 \text{ bar}$	7.5 to 40	10 to 55	15 to 90

¹⁾ 7 to 35 m³/h with 160 cm² actuator, 7 to 40 m³/h with 320 cm² actuator

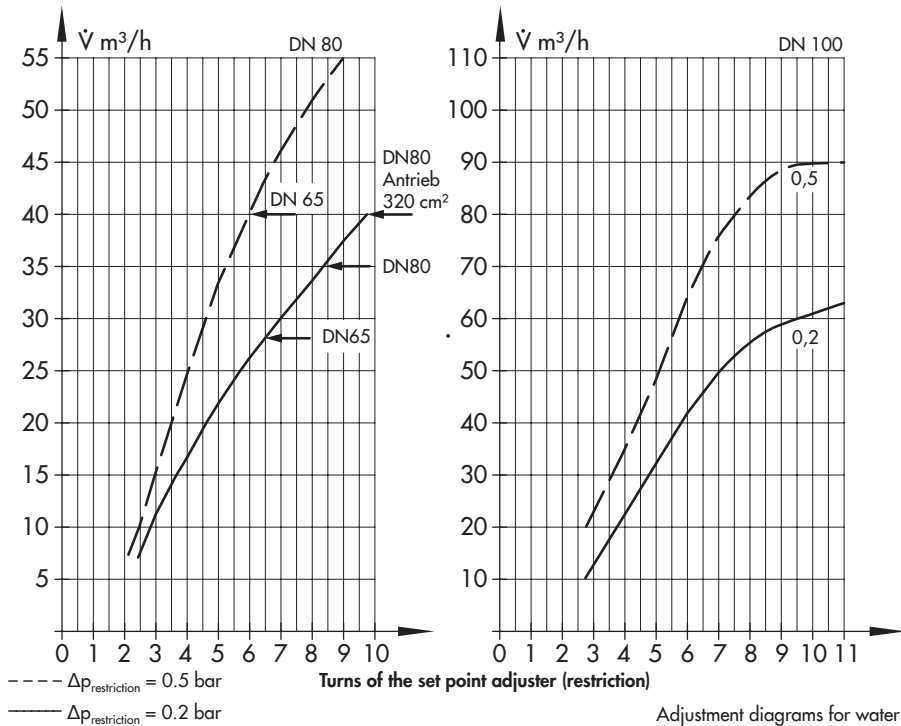

Fig. 3: Adjustment diagrams for Type 2423 E, balanced by a bellows or diaphragm, DN 65 to 100

4. Turn the set point adjuster (2.3) counter-clockwise by the corresponding number of turns.
5. Thread the lock nut (2.2) clockwise as far as it will go onto the threaded rod (2.1). The restriction opens until the adjusted set point is reached.
6. Check the flow rate and correct it, if necessary. Secure this setting with the locking screw (2.6).
7. Retract the actuator stem (1.1) using the manual override. Place the actuator on the restriction connection. Secure it by tightening the hex nut (1.3) (tightening torque 150 Nm).
8. Extend the actuator stem all the way to the threaded rod (2.1) using the manual override.
9. Position clamps of the stem connector (1.2) and screw them tight.
10. Thread the lock nut (2.2) all the way to the top toward the stem connector clamps (1.2) and lock or secure in place.

Adjustment with Type 3374 or Type 5824-30 Actuator · See Fig. 4 on page 13

More details on the Type 3374 Actuator in
 ► EB 8331-1 · Type 5824-30 Actuator in
 ► EB 5824-1/EB 5824-2

1. Extend the actuator stem (1.1) all the way to close the restriction (2.7) using the manual override (4 mm hexagon wrench) or by applying an electric control signal. The lock nut (2.2) must be threaded upward against the stem connector (1.2).

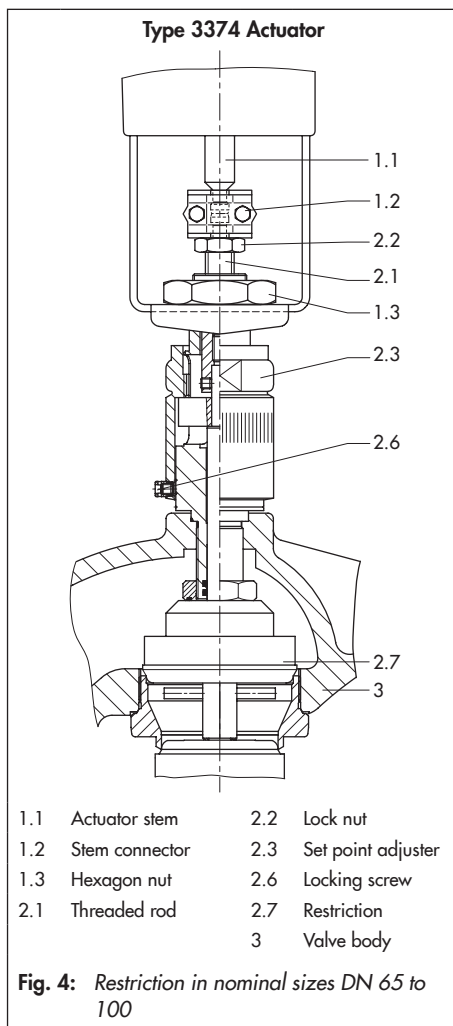

2. Loosen the locking screw (2.6). Turn the set point adjuster (2.3) clockwise as far as it will go (close the restriction).

3. Determine the turns required to achieve the desired flow rate from the adjustment diagrams (see Fig. 3) and turn the set point adjuster (2.3) counterclockwise the required number of turns (to open the restriction).
4. Secure this setting with the locking screw (2.6).

Manual changes or changes in the control signal to retract actuator stem now cause the restriction to open until the flow rate reaches the adjusted set point.

5.2.3 DN 125 to 250 with Type 3274 or Type 3374 Actuator

Adjustment without actuator · See Fig. 7 on page 17

1. Thread the lock nut (2.2) upwards to the head of the threaded rod (2.1).
2. Press the threaded rod (2.1) downward to close the restriction.
3. Loosen the locking screw (2.6). Turn the set point adjuster (2.3) until the scale reading 0 is located above the red groove mark.
4. Thread the lock nut (2.2) downward against the set point adjuster (2.3). Make sure that the threaded rod does not get turned by holding the threaded rod (2.1) stationary at the flattened part using a wrench.
5. Determine the required scale value for the desired flow rate using the adjustment diagrams on page 15 and Fig. 6 on page 16.
6. Turn the hex nut on the set point adjuster (2.3) until the previously determined scale reading is located above the red groove mark (2.5) on the reference ring.
7. Check the flow rate using a flow meter (integrated in the heat meter) and readjust it, if necessary.
8. Secure this setting by tightening the locking screw (2.6) and lead-seal it.
9. Thread the lock nut (2.2) upwards to the head of the threaded rod (2.1).
10. Extend the actuator stem (1.1) using the manual override. Place the actuator on the yoke and screw tight.
11. Position clamps of the stem connector (1.2) and screw them tight.
12. Thread the lock nut all the way to the top toward the stem connector and lock or secure in place.

Flow rate set point ranges for water · Type 2423 E Regulator, balanced by a bellows

Set point ranges in m ³ /h with ...	DN 125	DN 150	DN 200	DN 250
Diff. pressure at restriction $\Delta p_{\text{restriction}} = 0.2 \text{ bar}$	40 to 80	50 to 120	70 to 180	90 to 220
Diff. pressure at restriction $\Delta p_{\text{restriction}} = 0.5 \text{ bar}$	60 to 120	75 to 180	100 to 260	120 to 300

Adjustment diagrams for water

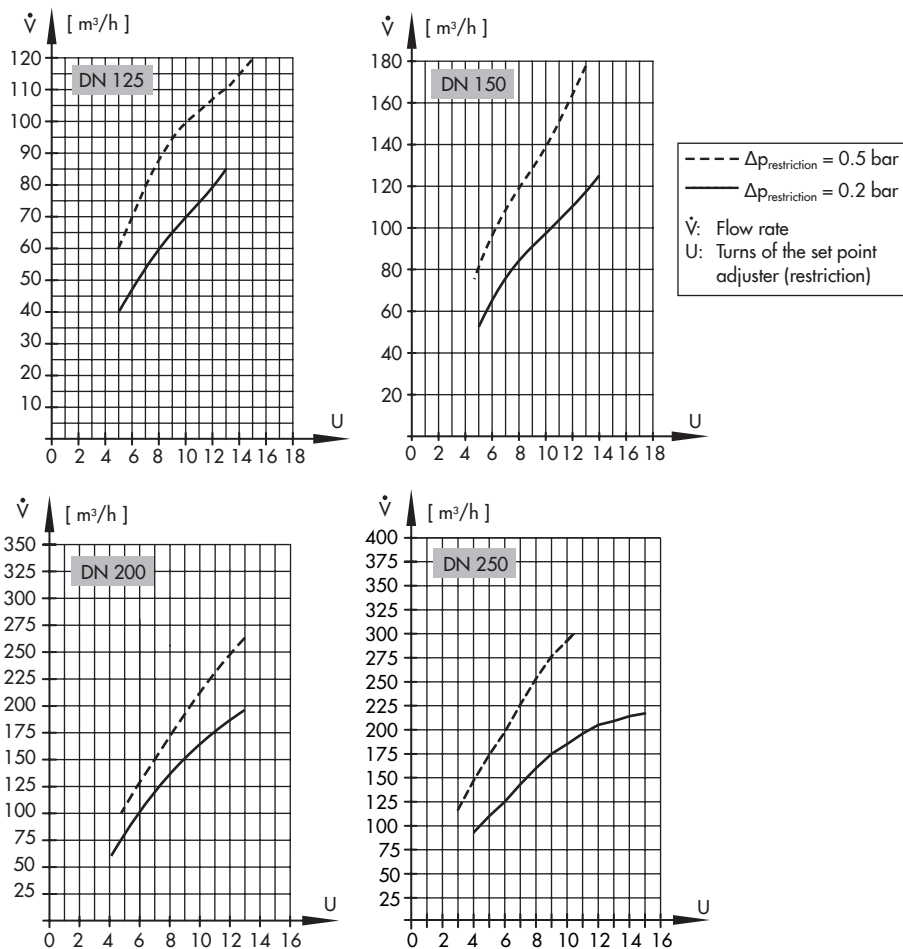

Fig. 5: Adjustment diagrams for Type 2423 E Regulator, **balanced by a bellows**, DN 125 to 250

Adjustment with Type 3274 or Type 3374 Actuator · See Fig. 7 on page 17

More details on the Type 3274 Actuator in

▶ EB 8340 and Type 3374 Actuator in

▶ EB 8331

1. Close the restriction. To do this, extend the actuator stem (1.1) of the actuator (1)

as far as it will go by pressing the electric override button (or the manual mode of the controller).

2. Remove the stem connector (1.2) and retract the actuator stem to the top end position using the manual override.

Flow rate set point ranges for water · Type 2423 E Regulator, balanced by a diaphragm

Set point ranges in m ³ /h with ...	DN 125	DN 150	DN 200	DN 250
Diff. pressure at restriction $\Delta p_{\text{restriction}} = 0.2$ bar	40 to 90	50 to 140	70 to 220	90 to 260
Diff. pressure at restriction $\Delta p_{\text{restriction}} = 0.5$ bar	50 to 130	60 to 200	80 to 310	100 to 360

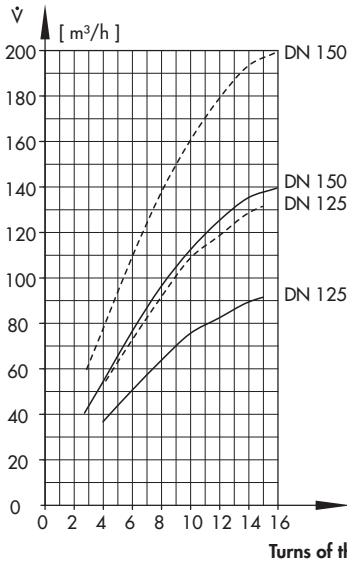

DN 125, DN 150 · A = 320 cm²,
balanced by a diaphragm

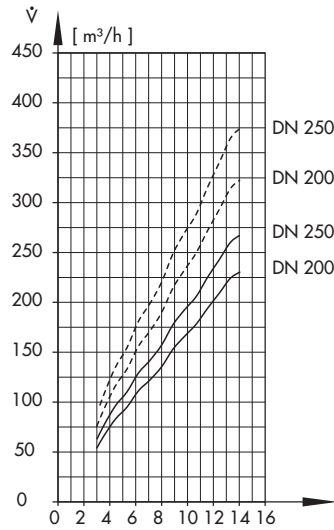

DN 200, DN 250 · A = 640 cm²,
balanced by a diaphragm

----- $\Delta p_{\text{restriction}} = 0.5$ bar
 ———— $\Delta p_{\text{restriction}} = 0.2$ bar

Adjustment diagrams for water

Fig. 6: Adjustment diagrams for Type 2423 E Regulator, balanced by a diaphragm, DN 125 to 250

3. Thread the lock nut (2.2) downward against the set point adjuster (2.3). Make sure that the threaded rod does not get turned by holding the threaded rod (2.1) stationary at the flattened part using a wrench.
4. Determine the required scale value for the desired flow rate using the adjustment diagrams (see Fig. 5 and Fig. 6).
5. Loosen the locking screw (2.6). Turn the hex nut on the set point adjuster (2.3) until the previously determined scale reading is located above the red groove mark on the reference ring.
6. Check the flow rate using a flow meter (integrated in the heat meter) and readjust it, if necessary.
7. Secure this setting by tightening the locking screw (2.6) and lead-seal it.
8. Extend the actuator stem (1.1) as far as it will go using the manual override.
9. Position clamps of the stem connector (1.2) and screw them tight.
10. Slightly retract the actuator stem to allow the lock nut (2.2) to move. Thread the lock nut to the top toward the stem connector to lock the setting.

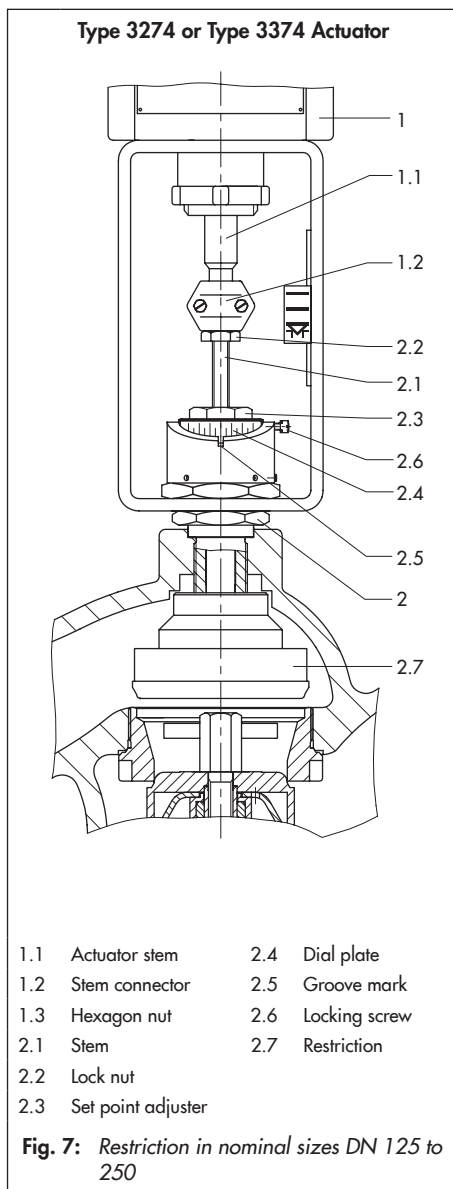

6 Dimensions and weights

Dimensional drawings · Type 2423 E Valve balanced by a bellows · DN 15 to 250

DN 15 to 80

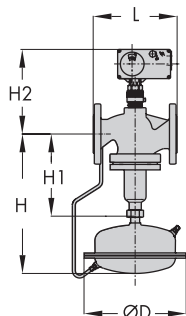

Type 42-36 E · Type 5824/5825 Actuator

DN 65 to 100

DN 125 to 250

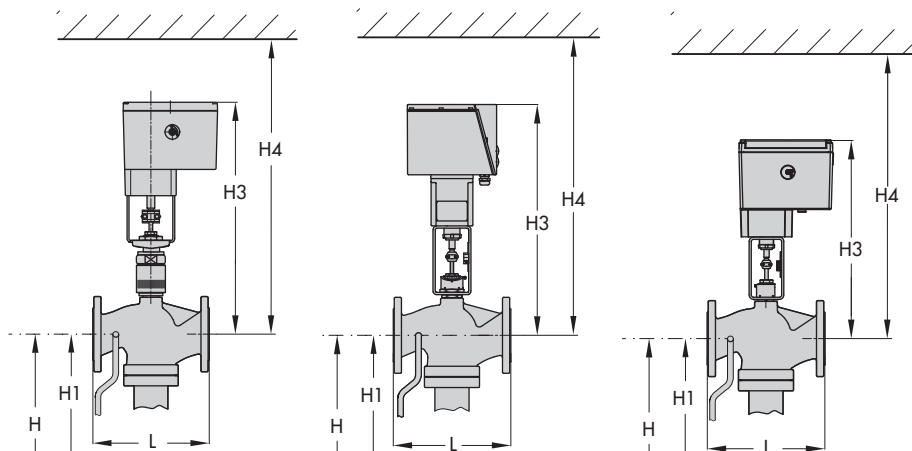

Type 42-36 E · Type 3374 Actuator

Type 42-36 E · Type 3274 Actuator

Type 42-36 E · Type 3374 Actuator

Fig. 8: Dimensions of the regulators, Type 2423 E Valve balanced by a bellows

Dimensions in mm and weights · Type 2423 E Valve balanced by a bellows · DN 15 to 250

		With Types 5824-10/-20 or Types 5825-10/-20 Actuator						Type 3374-11/21 Actuator		
Nominal size	DN	15	20	25	32	40	50	65	80	100
Length L		130	150	160	180	200	230	290	310	350
Height H1		225						300		355
Height H2	1.4571	218	–	240	–	260	266	–		
	Other materials	220			240			–		
Height H3		–						520		540
Height H4		–						820		890
Type 42-36 E PICV										
Height H		390						465		520
Diaphragm actuator		ØD = 225 mm, A = 160 cm ² 2)								
Weight for PN 16 ¹⁾ in kg (approx.)		13.5	14	15	21.5	22	24.5	51	56	71
		With Types 3274-11/-21 Actuator				With Type 3374-15 Actuator				
Nominal size	DN	125	150	200	250	125	150	200	250	
Length L		400	480	600	730	400	480	600	730	
Height H1		460	590	730	730	460	590	730	730	
Height H3		680	710	825	825	510	595	660	690	
Height H4		830	860	975	975	860	950	1010	940	
Type 42-36 E PICV										
Height H		625	765	895	895	625	765	895	895	
Diaphragm actuator		ØD = 285 mm, A = 320 cm ² 3)								
Weight for PN 16 ¹⁾ in kg (approx.)		135	185	440	500	125	170	425	485	

¹⁾ +10 % for cast steel PN 40 and spheroidal graphite iron PN 25

²⁾ Optionally with 320 cm² actuator for DN 65 to 100. For regulators with double adapter (see ► T 3019) for DN 65 to 100: 320 cm² actuator recommended.

³⁾ Optionally with 640 cm² actuator and ØD = 390 mm

Fig. 9: Table of dimensions

Dimensional drawings · Type 2423 E Valve **balanced by a diaphragm** · DN 65 to 250

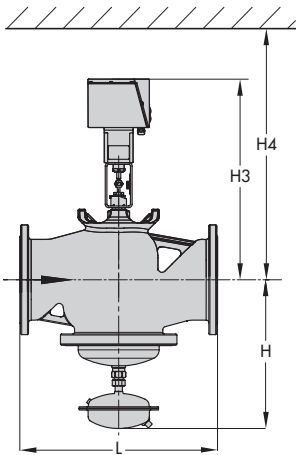

Dimensions in mm and weights with **Type 3274-11/-21 Actuator**

Nominal size DN	125	150	200	250
Length L	400	480	600	730
Height H	450	475	545	545
Height H3	680	710	825	825
Height H4	830	860	975	975
Weight ¹⁾ , approx. kg	100	120	300	320

¹⁾ Based on cast iron (EN-JL1040), other materials +10 %

Type 42-36 E with Type 3274-11/-21 Electrohydraulic Actuator

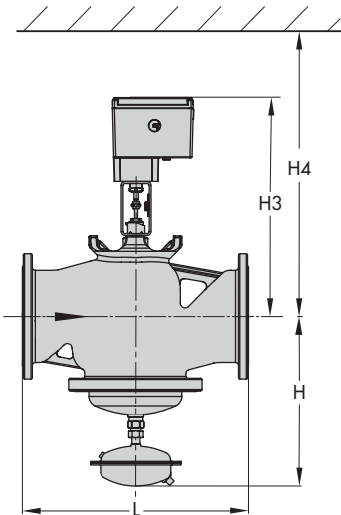

Dimensions in mm and weights with **Type 3374-... Actuator**

Nominal size DN	Types 3374-11/-21			Type 3374-15			
	65	80	100	125	150	200	250
Length L	290	310	350	400	480	600	730
Height H	355		380	450	475	545	545
Height H3	520		540	510	595	660	690
Height H4	820		890	860	950	1010	940
Weight ¹⁾ , approx. kg	46	51	68	90	110	290	310

¹⁾ Based on cast iron (EN-JL1040), other materials +10 %

Type 42-36 E with Type 3374-11/-21/-15 Electric Actuator

Fig. 10: Dimensions of the regulators, Type 2423 E Valve balanced by a diaphragm

Dimensional drawings · Type 2423 E Valve balanced by a diaphragm · DN 65 to 100

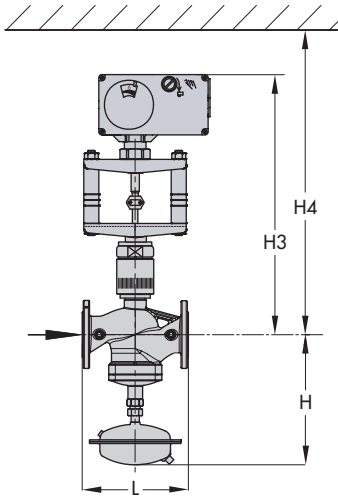

Dimensions in mm and weights with Type 5824-30 Actuator

Nominal size DN	65	80	100
Length L	290	310	350
Height H	355		380
Height H3	520		540
Height H4	820		890
Weight ¹⁾ , approx. kg	46	51	65

¹⁾ Based on cast iron (EN-JL1040), other materials +10 %

Type 42-36 E with Type 5824-30 Electric Actuator

Fig. 11: Dimensions of the regulators, Type 2423 E Valve balanced by a diaphragm

7 Technical data

Technical data · Valves · All pressures in bar (gauge)

Type 2423 E Valve, balanced by a bellows													
Nominal size DN	15	20	25	32	40	50	65	80	100	125	150	200	250
Nominal pressure	PN 16, 25 and 40												
Max. medium temperature	150 °C												
Max. ambient temperature	50 °C												
Differential pressure at the restriction $\Delta p_{\text{restriction}}$	0.2 bar · 0.5 bar												

Type 2423 E Valve, balanced by a diaphragm													
Nominal size	DN 65 to 250												
Nominal pressure	PN 16, 25 or 40												
Max. medium temperature	150 °C												
Max. ambient temperature	50 °C												
Differential pressure at the restriction $\Delta p_{\text{restriction}}$	0.2 bar · 0.5 bar												

K_{VS} coefficients, z values and max. permissible differential pressures Δp

Type 2423 E Valve, balanced by a bellows													
Nominal size DN	15	20	25	32	40	50	65	80	100	125	150	200	250
Valve travel	10 mm					16 mm				22 mm			
K_{VS} coefficient	4	6.3	8	16	20	32	50	80	125	190	280	420	500
z value	0.65	0.6	0.55		0.45	0.4		0.35				0.3	
Max. perm. differential pressure Δp	25 bar					20 bar			16 bar	12 bar	10 bar		

Type 2423 E Valve, balanced by a diaphragm														
Nominal size DN	65		80		100		125		150		200		250	
Valve travel	16 mm													
K_{VS} coefficient in m^3/h	35 mm travel		50	80	125	250	380	650	800					
z value	0.4		0.35			0.35			0.3					
Max. perm. differential pressure Δp	10 bar					12 bar			10 bar					

8 After-sales service

If malfunctions or defects occur, contact the SAMSON After-sales Service department for support.

Please send your after-sales inquiries to:
aftersalesservice@samson.de.

The addresses of SAMSON AG, its subsidiaries, representatives and service facilities worldwide can be found on the SAMSON website (► www.samson.de), in all SAMSON product catalogs or on the back of these Mounting and Operating Instructions.

To assist diagnosis, specify the following details:

- Device type and nominal size
- Order and model number
- Upstream and downstream pressure
- Min. and max. flow rate in m³/h
- Is a strainer installed?
- Installation drawing



Note:

Conversion from chromate coating to iridescent passivation

We at SAMSON are converting the surface treatment of passivated steel parts in our production. As a result, you may receive a device assembled from parts that have been subjected to different surface treatment methods. This means that the surfaces of some parts show different reflections. Parts can have an iridescent yellow or silver color. This has no effect on corrosion protection.

For further information go to ► www.samson.de/chrome-en.html



SAMSON AG · MESS- UND REGELTECHNIK
Weismüllerstraße 3 · 60314 Frankfurt am Main, Germany
Phone: +49 69 4009-0 · Fax: +49 69 4009-1507
samson@samson.de · www.samson.de

EB 3018 EN

2017-06-26 · English