

**Differential Pressure and Temperature Regulator
with Flow Limiter
Type 2479/2430 K**



**Special version DN 15
with differential pressure set point $\Delta p = 0.5$ bar**

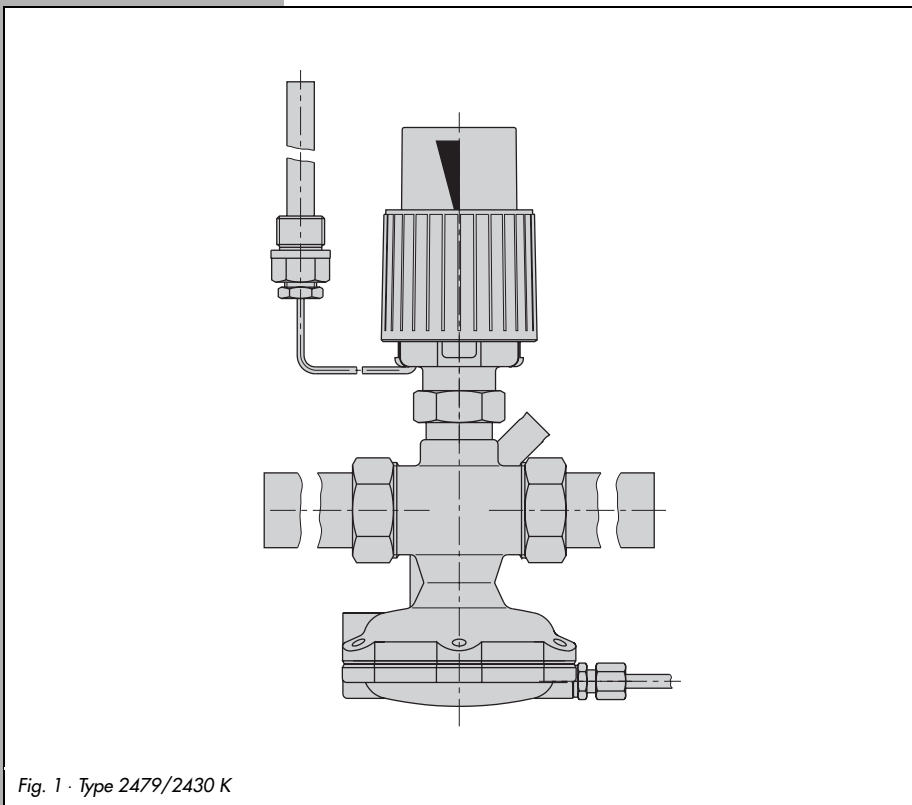

Fig. 1 · Type 2479/2430 K

**Mounting and
operating instructions**

EB 3132-4 EN

Edition November 2000

1. Design and principle of operation

The regulator consists of a control valve with restriction, seat and plug, a closing actuator with operating diaphragm and a thermostat with set point adjuster, capillary tube and temperature sensor. The regulator is designed to maintain the differential pressure and the temperature at the adjusted set point. The flow limiter can be adjusted by turning the adjusting screw (8.3) located in the valve body. The valve closes when the controlled value increases.

The process medium flows through the valve in the direction indicated by the arrow. The free area between the adjustable restriction (baffle plate) (8.5) and the plug (3) determines the flow rate. The high pressure of the plant (flow line) is transmitted to the lower diaphragm chamber of the actuator via the

control line (7) provided by the customer.

The low pressure downstream of the restriction is applied to the low pressure side of the operating diaphragm (6.1) through a bore in the plug. The differential pressure created by the restriction (baffle plate) is converted into a positioning force acting on the operating diaphragm. This force is used to move the plug according to the force of the positioning spring (5).

In the sensor, the temperature of the medium produces a pressure which is transmitted to the operating bellows (23) via the capillary tube (24) and converted into a positioning force. This force is used to move the baffle plate (8.5) via the coupling rod (9) according to the force of the spring (21) pre-tensioned by the set point adjuster (22). The largest signal is always used to actuate the valve.



- ▶ *Assembly, start-up and operation of the device may only be performed by trained personnel familiar with this product.*
- ▶ *According to these mounting and operating instructions, trained personnel refers to individuals who are able to judge the work they are assigned to and recognize potential hazards due to their specialized training, their knowledge and experience as well as their knowledge of the applicable standards.*
- ▶ *Any hazards which could be caused at the regulator by the process medium or the operating pressure must be prevented by means of appropriate measures.*
- ▶ *Moreover, it must be ensured that the control valve is only used in applications where operating pressure and temperatures do not exceed the operating values which are based on the valve sizing data submitted with the order.*
- ▶ *Proper shipping and appropriate storage are assumed.*

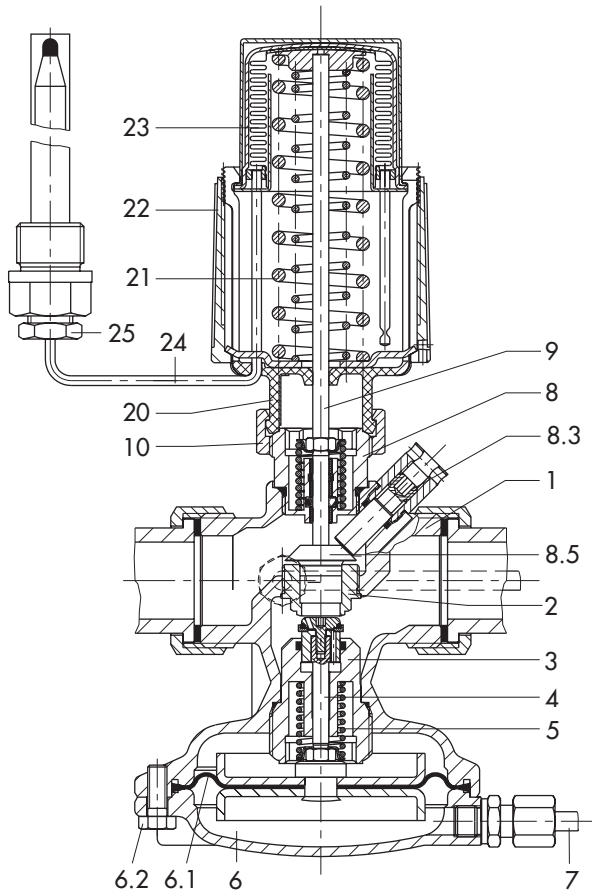

- | | |
|-------------------------------------|--------------------------------|
| 1 Valve body | 8.3 Adjusting screw |
| 2 Seat | 8.5 Baffle plate (restriction) |
| 3 Plug | 9 Coupling rod |
| 4 Plug stem | 10 Connection nut |
| 5 Positioning spring | 20 Control thermostat |
| 6 Actuator | 21 Spring |
| 6.1 Operating diaphragm with plates | 22 Set point adjuster |
| 6.2 Screws | 23 Operating bellows |
| 7 Control line | 24 Capillary tube |
| 8 Mounting part | 25 Temperature sensor |

Tightening torques		
Pos. 10	Connection nut	20 Nm
Pos. 3	Plug	70 Nm
Pos. 6.2	Screws	8 Nm

Fig. 2 · Sectional drawing

2. Installation

The regulator should generally be installed into the low pressure line, e.g. the return flow pipe. When used in district heating systems, the regulator must only be installed into the return flow pipe.

2.1 Mounting position

Install the regulator in the horizontal pipeline so that either the actuator or the thermostat is vertically suspended. (Note that the actuator must face upward and that the thermostat must face downward if the medium temperature exceeds a maximum of 110°C).

Use the supplied screw joints with weld-on fittings for standard connection.

The medium must flow through the valve in the direction indicated by the arrow on the valve body.

2.2 Control line

The control line with a pipe diameter of 6 mm must be adapted and installed on site. For the piping arrangement, refer to the installation schematics, Fig. 3.

2.3 Strainer

Since sealing particles, globules and other impurities carried along by the process medium could impair the proper functioning of the valve, especially tight shut-off, a strainer (SAMSON Type 1NI) should be installed upstream of the regulator.

The strainer must be installed so that the medium flows through it in the direction indicated by the arrow on the strainer body. The filter insert must be vertically suspended. Make sure that ample space is available to remove the filter.

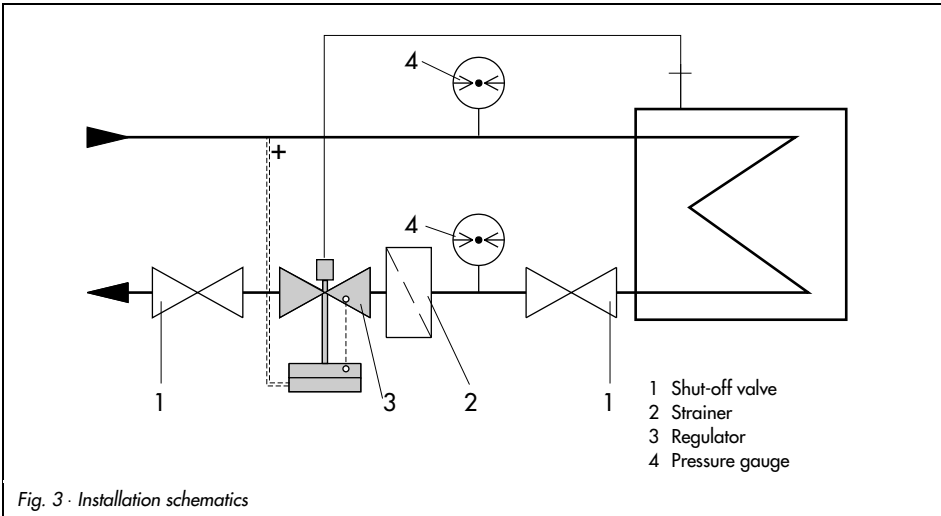

Fig. 3 · Installation schematics

2.4 Additional installation instructions

We recommend that you install one hand-operated shut-off valve upstream of the strainer and one downstream of the regulator. This allows the plant to be shut down for cleaning the strainer or maintaining the regulator.

To monitor the pressures prevailing in the plant, install one pressure gauge upstream and one downstream of the regulator. To monitor the adjusted temperature set point, a thermometer must be installed and immersed in the controlled medium near the sensor.

2.5 Installing the temperature sensor

For further details on the Type 2430 K Thermostat, refer to the "Mounting and operating instructions" EB 2430 EN.

For the Type 2430 (vapor pressure), refer to EB 2430-3 EN.

The temperature sensor of the Type 2430 K Thermostat may be mounted in any desired position. It must be entirely immersed in the controlled medium. The sensor should be installed in a location where overheating or considerable idle times cannot occur.

A welding socket with a G 1/2 or G 3/4 female thread connection should be welded to the position where the sensor is to be installed.

Seal the screw gland or thermowell into the welding socket. Insert the sensor and fasten it with the clamping screw.



CAUTION

To prevent damage caused by corrosion, it is important to make sure on installing the sensor or thermowell that only the same kind of materials are used together. For instance, do not use a sensor or thermowell made of non-ferrous metal in a stainless steel heat exchanger. In this case, the sensor should be used together with a stainless steel thermowell.

2.5.1 Capillary tube

The capillary tube should be routed such that it cannot be damaged. The smallest bending radius must be minimum 50 mm. Any excess tube should be neatly coiled up. The tube may not under any circumstances be bent or shortened. The ambient temperature around the tube should fluctuate as little as possible.

2.6 Assembling the valve and the thermostat

Attach the thermostat to the mounting part of the valve and screw it down by means of a connection nut (10), tightening torque 20 Nm.

3. Operation – adjusting the set point

3.1 Adjusting the flow rate set point

All consumers in the system must be open (minimum system resistance). Bypass lines, if applicable, must be closed.

To adjust or change the set point of the flow limiter, proceed as follows:

- ▶ First, set the temperature to the maximum value using the set point adjuster.
Note: This value must always exceed the actual system value so that the thermostat does not affect the baffle plate stem.
- ▶ Then adjust the flow rate by turning the lateral adjusting screw (8.3) by means of an Allen key (width across flats 4):
- ▶ Turn the screw counterclockwise to open the baffle plate and to increase the flow rate.
- ▶ Turn the screw clockwise to close the baffle plate and to reduce the flow rate.

Note:

The baffle plate is closed when delivered.

- ▶ Adjust the flow rate using a reference device (e.g. a calorimetric meter) and lead-seal it, if required.

3.1 Adjusting the temperature set point

Adjust the temperature set point using the black plastic set point adjuster (22) while watching the reference thermometer.

The adjustment is continuously variable.

Turn the adjuster clockwise to reduce the temperature, and turn it counterclockwise to increase the temperature.

The temperature can be fixed at an adjusted value by lead-sealing the bore in the set point adjuster.

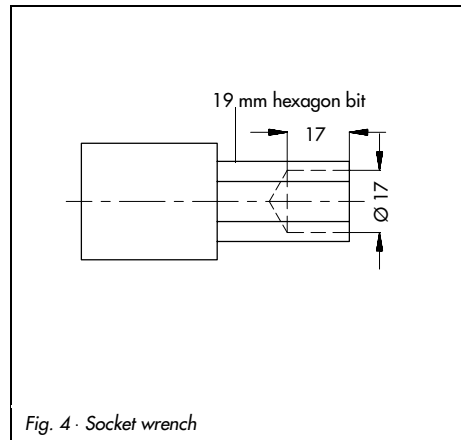

Fig. 4 · Socket wrench

4. Troubleshooting

If the valve does not close tightly, the cause may be a contaminated seat or plug, or valve seat and plug no longer give tight shut-off because of wear and tear. If the flow rate deviates considerably from the adjusted set point, e.g. rapidly increasing flow rate, inspect the operating diaphragm for leaks and replace it, if necessary.



CAUTION

Always relieve the pressure from the part of the plant to be worked on and drain it prior to performing any assembly work on the regulator. Remove the regulator from the pipeline to perform any assembly work.

4.1 Cleaning or replacing the plug

1. Unscrew the thermostat and the control line, and remove the regulator from the pipeline.
2. Loosen the screws (6.2) and remove the lower diaphragm case with the diaphragm (6.1) and the diaphragm plates.
3. Unscrew and remove the guide nipple of the plug section (3) using a socket wrench (Order No. 1280-3001).
This wrench can be made, for instance, from a GEDORE screwdriver bit (IN 19-19) by boring a 17-mm hole with a diameter of 17 mm into the 19-mm hexagon bit as shown in Fig. 4.
4. Clean the seat and plug thoroughly.

Should the plug be damaged, replace the complete plug section.

5. Check the control line for any blockages.
6. To reassemble the regulator, proceed in reverse order. Apply the tightening torques according to Fig. 2.

4.2 Replacing the diaphragm

1. Unscrew the thermostat and the control line (7).
2. Loosen the screws (6.2) and remove the lower diaphragm case with the diaphragm and diaphragm plates.
3. Replace the complete diaphragm section including the diaphragm plates.
4. To reassemble the regulator, proceed in reverse order.

4.3 Replacing the baffle plate

1. Unscrew the coupling nut in order to remove the thermostat from the mounting part of the valve.

CAUTION

Unscrew the adjusting screw (8.3) before proceeding!

2. Unscrew the mounting part (8) including the baffle plate by means of a socket wrench (see Fig. 4, Order No. 1280-3001) and pull it out of the valve body.
3. Replace the parts. To reassemble the regulator, proceed in reverse order. Apply the tightening torques according to Fig. 2.

5. Dimensions in mm

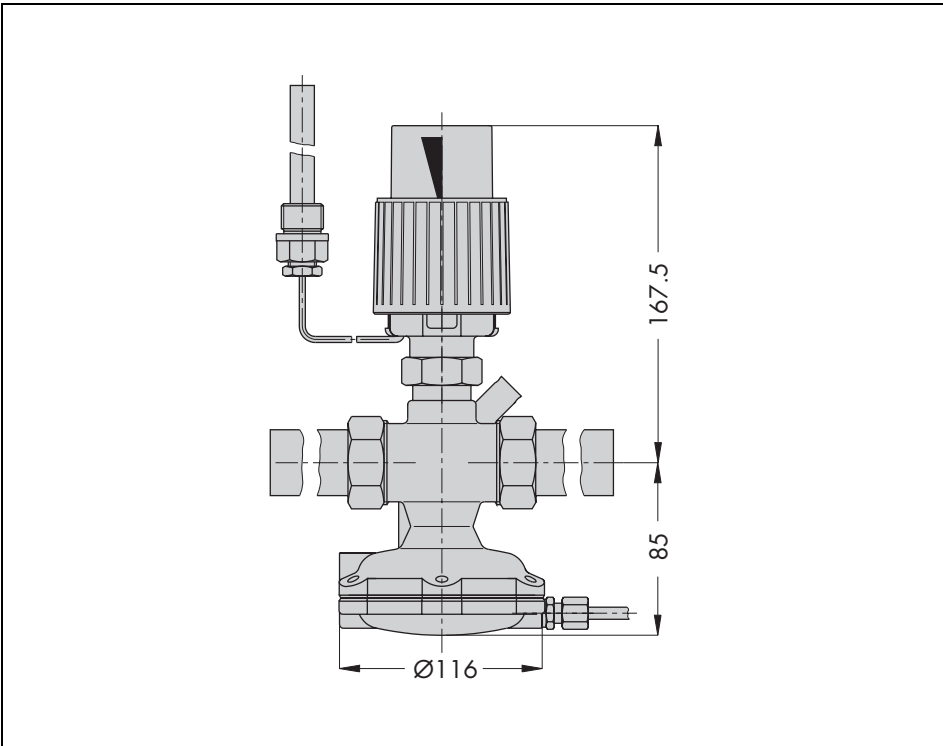

6. Customer inquiries

Should you have any inquiries about the regulator, please submit the following details:

- ▶ Type and nominal size
- ▶ Model Number (see nameplate)
- ▶ Upstream and downstream pressures of the valve
- ▶ Flow rate in m^3/h
- ▶ Has a strainer been installed?
- ▶ Installation drawing



SAMSON AG · MESS- UND REGELTECHNIK
Weismüllerstraße 3 · D-60314 Frankfurt am Main
Phone (0 69) 4 00 90 · Telefax (0 69) 4 00 95 07
Internet: <http://www.samson.de>

EB 3132-4 EN

S/C 2001-01