

**Differential Pressure Regulator
with Flow Limitation
Type 46-5 N**

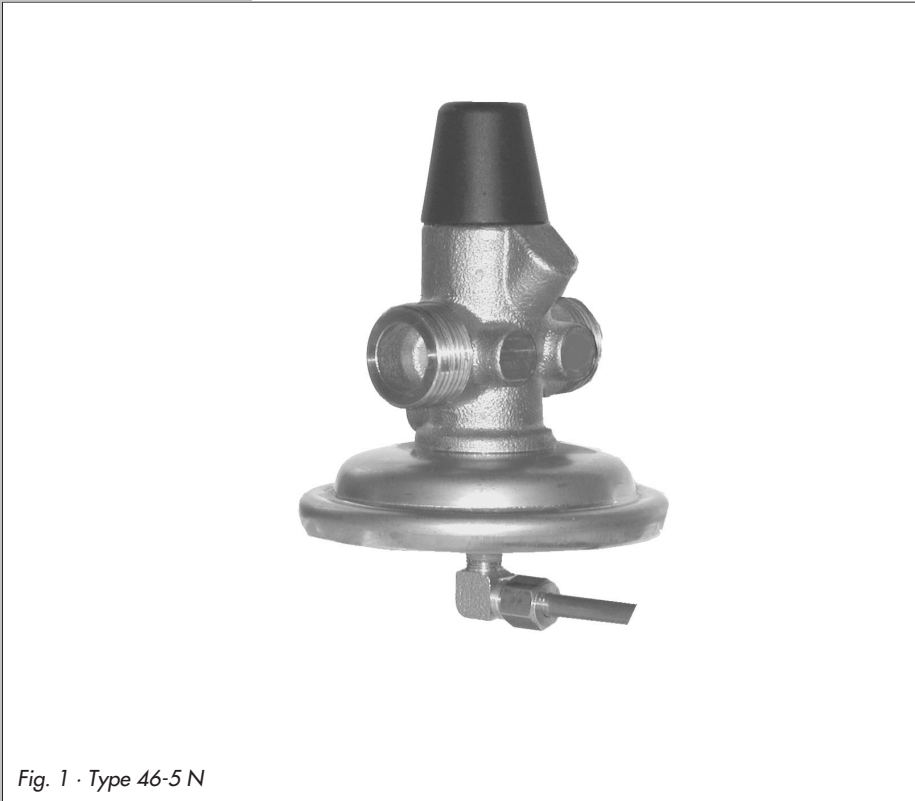

Fig. 1 · Type 46-5 N

**Mounting and
Operating Instructions**

EB 3134 EN

Edition January 2002

1 Design and principle of operation

The differential pressure regulator consists of the valve body including restriction, seat and plug as well as the closing actuator with diaphragm.

The regulator is designed to limit the differential pressure to a fixed value (0.3 or 0.5 bar) and the flow rate to the adjusted set point especially in local heat supply networks and heating systems.

The medium flows through the valve in the direction indicated by the arrow. The adjustable restriction (11) and the free area released by the valve plug (3) determine the flow rate.

The high pressure in front of the restriction is transmitted to the high pressure side of the actuator by a control line (7) attached on installing the regulator. The low pressure down-

stream of the restriction is transmitted to the low pressure side (10) of the diaphragm (9) via a bore in the valve plug. The differential pressure created by the restriction is converted at the diaphragm into a positioning force. If this force exceeds the force of the installed spring (5), the valve closes. In the same manner, the valve opens if the positioning force falls below the spring force.

The flow rate can be restricted by turning the set point screw to change the flow cross-section at the restriction.



General safety instructions

- ▶ *The regulators must be installed, started up and serviced by fully trained and qualified personnel only, observing the accepted industry codes and practices. Make sure employees or third persons are not exposed to any danger. According to these mounting and operating instructions, trained personnel refers to individuals who are able to judge the work they are assigned to and recognize possible dangers due to their specialized training, their knowledge and experience as well as their knowledge of the relevant standards.*
- ▶ *Any hazards which could be caused in the regulator by the process medium or operating pressure are to be prevented by means of appropriate measures.*
- ▶ *Make sure that the regulator is only used in applications where the operating pressure and temperatures do not exceed the operating values based on the sizing data submitted in the order.*
- ▶ *Proper shipping and appropriate storage are assumed.*

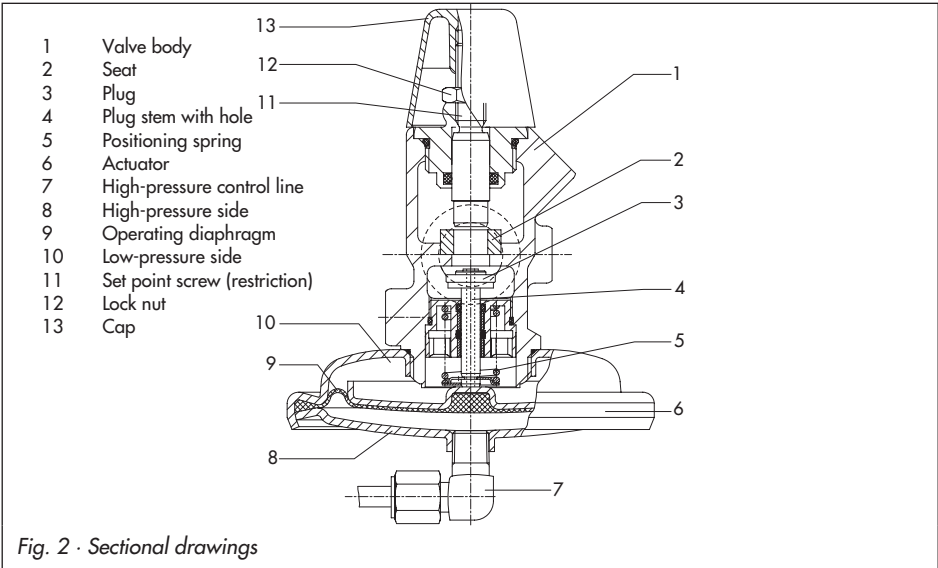

2 Installation

2.1 Mounting position

The differential pressure and flow limiter must preferably be installed in horizontal pipelines with the actuator suspended downwards.

The regulator must be installed in low pressure pipes. This line is always the return flow pipe in local heat networks.

The medium must flow through the valve in the direction indicated by the arrow on the valve body.

2.2 Control line

A control line with a 6 mm diameter must be adapted and attached at the place of installation. Route the control line as indicated in the installation drawing.

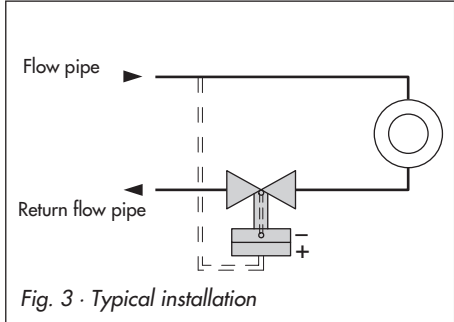

2.3 Strainer

Since sealing parts, globules and other impurities carried along by the medium may impair the proper functioning of the valve and especially the tight shut-off, a strainer (SAMSON Type 1 NI) must be installed upstream of the differential pressure regulator.

- ▶ Install the strainer so that the medium flows through it in the direction indicated by the arrow on the strainer body.
- ▶ The filter element must be suspended downwards.
- ▶ Remember to leave enough space to remove it.

2.4 Shut-off valves and pressure gauges

We recommend the installation of hand-operated shut-off valves both upstream and downstream of the strainer. This allows the plant to be shut down for cleaning or maintenance or when the plant is not operated for extended periods.

Install a pressure gauge upstream and downstream of the valve to monitor the pressures prevailing in the plant.



NOTICE

Prior to start-up or applying pressure to the regulator, open the restriction for the flow limitation.

3 Set point adjustment

- ▶ All consumers in the plant must be opened (for minimum resistance in the plant). If a bypass is installed in the plant, it must be closed.
1. Unscrew the cap (13).
 2. Loosen the lock nut (12) and turn the set point screw (11) using a 4 mm Allen key.
- ▶ Turning the screw (11) clockwise closes the restriction, causing the flow rate to drop.
 - ▶ Turning the screw counterclockwise opens the restriction, causing the flow rate to increase.

Use the diagram in Fig. 4 as a guide for adjustment.

3. After adjustment, screw tight the lock nut and screw back on the cap (13).

Example:

A regulator with $Kvs = 1.0$ and a flow rate range from 0.12 to $0.5 \text{ m}^3/\text{h}$ is intended to limit the flow rate to $0.3 \text{ m}^3/\text{h}$ in a plant. The differential pressure set point is 0.3 bar and the pressure drop in the plant is 0.15 bar . How many turns of the set point screw at the restriction are required to limit the flow rate?

Solution:

(in sequence **A** to **E** in the diagram)

The calculation is based on the pressure drop Δp in the plant, therefore, this value must be known!

$\Delta p = 0.15 \text{ bar}$ is specified in the example and corresponds with the point **A** in the diagram.

The final value of the differential pressure of 0.15 bar must be added up to the line of the differential pressure set point of 0.3 bar .

A line including this value is drawn from **A** across to the right and results in the point **B**.

A vertical line is drawn from point **B** until it reaches the required limiting curve for the flow rate ($0.3 \text{ m}^3/\text{h}$) at point **C**.

A horizontal line is drawn from point **C** to the curve for $K_{vs}=1.0$; this is point **D**.

When a line is drawn upwards from point **D**; this results in point **E** and indicates how many

times the set point screw must be turned. The example shows that slightly more than four counterclockwise turns of the set point screw are required, based on a closed restriction.

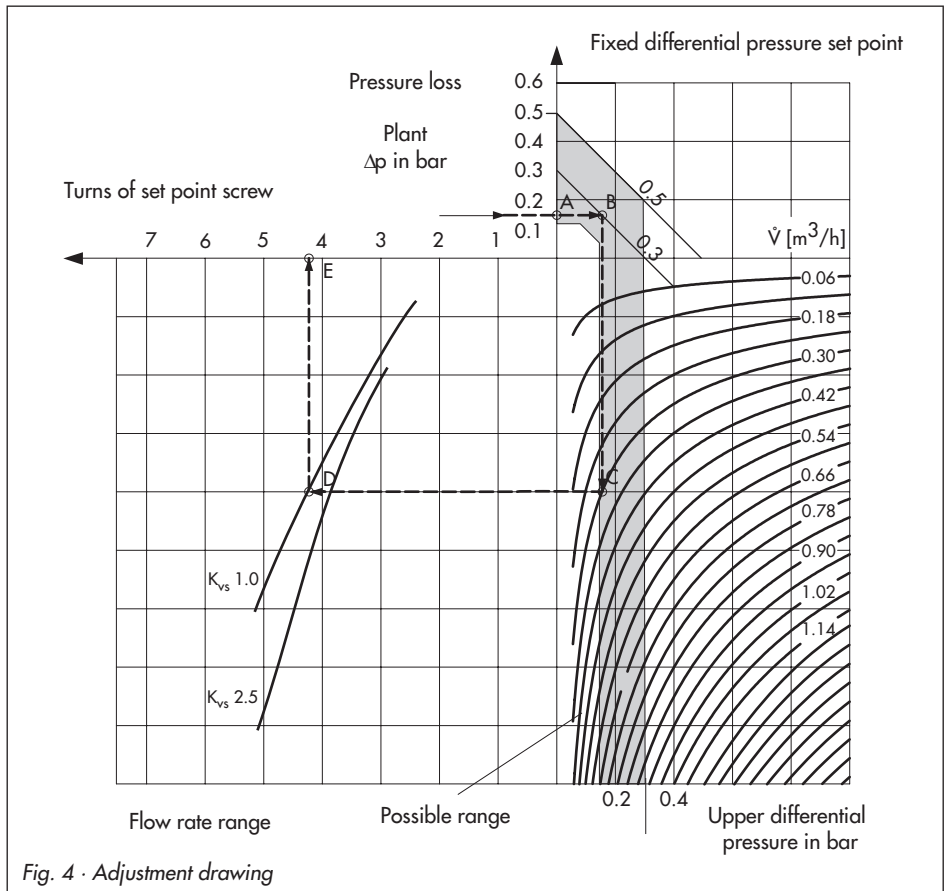

4 Troubleshooting

Should the flow rate deviate considerably from the adjusted set point, this could be caused either by dirt on the seat and plug or because they have become naturally worn and no longer provide tight shut-off. If the valve leaks, check the diaphragm for damage and replace, if necessary.



NOTICE

Always relieve the pressure from the plant section to be worked on and drain it prior to performing any assembly work on the regulator. Remove the regulator from the pipeline to perform any assembly work.

Allow regulator to cool down first.

5 Dimensions in mm

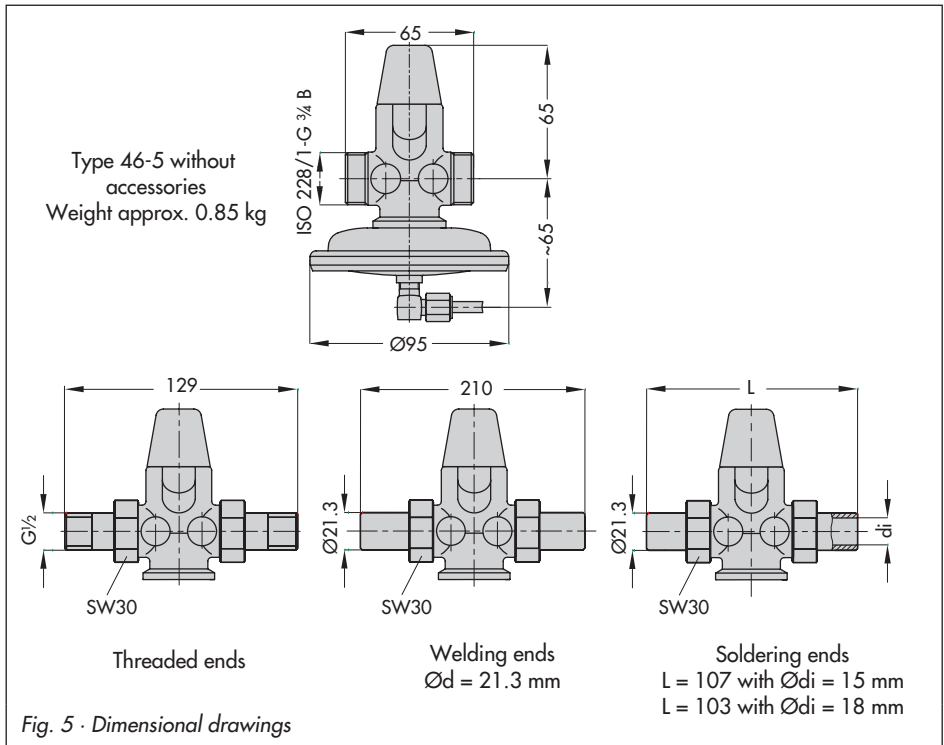

6 Customer inquiries

Should any malfunctions or any defect occur, SAMSON's After-Sales Service is prepared to help you on site.

You can also send the defective regulator directly to your local SAMSON representative for repair. Addresses of SAMSON subsidiaries, agencies and service centers are listed in the product catalogs and in the Internet at www.samson.de.

To allow SAMSON to find the fault and to have an idea of the installation situation, specify the following details (see nameplate):

- ▶ Type and nominal size of the regulator
- ▶ Order no. and product no. (written on nameplate)
- ▶ Upstream and downstream pressure
- ▶ Flow rate in m³/h
- ▶ Has a strainer been installed?
- ▶ Installation drawing



SAMSON AG · MESS- UND REGELTECHNIK
Weismüllerstraße 3 · 60314 Frankfurt am Main · Germany
Phone: +49 69 4009-0 · Fax: +49 69 4009-1507
Internet: <http://www.samson.de>

EB 3134 EN

S/Z2011-11