

Flow Regulators with Electric Actuator

SAMSON

Type 2488/5857, Type 2488/5824 and Type 2488/5825
Pressure-independent Control Valves



Type 2488 Flow Regulator with Type 5824 Electric Actuator

Mounting and Operating Instructions

EB 3135-1 EN

Edition July 2016



Note on these mounting and operating instructions

These mounting and operating instructions assist you in mounting and operating the device safely. The instructions are binding for handling SAMSON devices.

- For the safe and proper use of these instructions, read them carefully and keep them for later reference.
- If you have any questions about these instructions, contact SAMSON's After-sales Service Department (aftersaleservice@samson.de).



The mounting and operating instructions for the devices are included in the scope of delivery. The latest documentation is available on our website (www.samson.de) > Product documentation. You can enter the document number or type number in the [Find:] field to look for a document.

Definition of signal words



DANGER!

Hazardous situations which, if not avoided, will result in death or serious injury



NOTICE

Property damage message or malfunction



WARNING!

Hazardous situations which, if not avoided, could result in death or serious injury



Note:

Additional information



Tip:

Recommended action

1	General safety instructions	4
2	Process medium and scope of application	5
2.1	Transportation and storage	5
3	Design and principle of operation	5
4	Installation	6
4.1	Mounting position	6
4.2	Strainer	6
4.3	Additional installation instructions	8
5	Operation	8
5.1	Start-up.....	8
5.2	Set point adjustment.....	8
5.2.1	Adjustment without actuator.....	8
5.2.2	Adjustment with electric actuator	11
5.2.3	Adjustment with Type 5857 or Type 5824 Actuator	11
5.2.4	Adjustment with Type 5825 Actuator	12
6	Maintenance – Replacing parts	12
6.1	Replacing the restriction.....	13
6.2	Cleaning or replacing the plug.....	13
6.3	Replacing the diaphragm	14
7	Troubleshooting	15
8	Nameplate	16
9	Customer service	16
10	Dimensions	17
11	Technical data	19



1 General safety instructions

- The regulators are to be mounted, started up or serviced by fully trained and qualified personnel only; the accepted industry codes and practices are to be observed. Make sure employees or third persons are not exposed to any danger.
- All safety instructions and warnings given in these mounting and operating instructions, particularly those concerning installation, start-up and maintenance, must be strictly observed.
- According to these mounting and operating instructions, trained personnel refers to individuals who are able to judge the work they are assigned to and recognize possible dangers due to their specialized training, their knowledge and experience as well as their knowledge of the applicable standards.
- The regulators comply with the requirements of the European Pressure Equipment Directive 2014/68/EU. The EU declaration of conformity issued for a regulator bearing the CE marking includes information on the applied conformity assessment procedure.
The declaration of conformity can be provided on request.
- To ensure appropriate use, only use the regulator in applications where the operating pressure and temperatures do not exceed the specifications used for sizing the regulator at the ordering stage.
- The manufacturer does not assume any responsibility for damage caused by external forces or any other external factors.
- Any hazards that could be caused in the regulator by the process medium, operating pressure or by moving parts are to be prevented by means of the appropriate measures.
- Proper transport, storage, installation, operation and maintenance are assumed.

Note:

Non-electric actuators and control valve versions do not have their own potential ignition source according to the ignition risk assessment stipulated in EN 13463-1: 2009, section 5.2, even in the rare incident of an operating fault. Therefore, they do not fall within the scope of Directive 2014/34/EU.

For connection to the equipotential bonding system, observe the requirements specified in section 6.4 of EN 60079-14: 2014 (VDE 0165 Part 1).

2 Process medium and scope of application

Pressure-independent control valves for controlling the flow rate in district heating systems. Combined with an electric actuator used to transmit the control signal of an electric control device. Suitable for liquids up to 150 °C.

Install the regulator preferably in the return flow pipe of the plant.



NOTICE

The regulator is not a safety valve. If necessary, a suitable overpressure protection must be installed on site in the plant section.

2.1 Transportation and storage

The regulator must be carefully handled, transported, and stored. Protect the regulator against adverse influences, such as dirt, moisture or frost, during storage and transportation.

3 Design and principle of operation

See Fig. 1 on page 7.

These combined regulators consist of a valve, a diaphragm actuator, and an adjustable restriction (orifice) with an electric actuator (Type 5857, Type 5824 or Type 5825) connected to it.

As a result, it is possible to transmit the control signal of an electric control device to achieve additional temperature control by changing the restriction position.

A maximum flow rate can be adjusted mechanically at the restriction (orifice).

The **Type 2488/...** Regulator closes when the flow rate rises and/or when the output signal issued by the electric control device increases.

The medium flows through the valve in the direction indicated by the arrow on the valve body. The flow rate depends on the area released by the valve plug (3) and the adjustable restriction (8.5). The integral spring (5) determines the differential pressure at the restriction (0.2 bar).

The high pressure upstream of the restriction is transmitted to the high-pressure side of the diaphragm actuator through the control line (7). The low pressure downstream of the restriction acts on the low-pressure side of the operating diaphragm (6.1) through a hole in the valve plug. The differential pressure generated at the restriction is converted into a positioning force by the operating diaphragm. This force is used to move the valve plug depending on the force of the set point spring (5).

If the control valve is to be insulated, do not insulate actuator and coupling nut. Make sure the permissible ambient temperature is not exceeded, especially at the actuator stem (10.1). If necessary, an intermediate insulating piece (order no. 1992-3132) must be used. The insulating limit is in this case approx. 25 mm above the top of the valve body.



Note:

Observe the instructions for the electric actuators specified in EB 5824 ... and EB 5857. Type 5857 Electric Actuator as well as Types 5824-10 and 5825-10 Electric Actuators with a 6 mm rated travel are used for valves in sizes DN 15 to 25.

Types 5824-20 and 5825-20 Electric Actuators with 12 mm rated travel are required for valves in nominal sizes DN 32 to 50.

4 Installation

4.1 Mounting position

See Fig. 1 on page 7.

DN 15 to 25:

Installation in **horizontal** or **vertical** pipelines.

DN 32 to 50:

Installation in **horizontal** pipelines only.

Make sure the direction of flow corresponds with the arrow on the valve body.

When the regulator is installed in horizontal pipelines, the actuator must be located above the valve body.

4.2 Strainer

Install a strainer (e.g. SAMSON Type 1 NI) upstream of the regulator to prevent any sealing parts, weld spatter and other impurities carried along by the process medium impairing the proper functioning of the valve, above all the tight shut-off. Install the strainer in such a way that the direction of flow corresponds with the arrow on the strainer. The filter element must be installed to hang downwards. Remember to leave enough space to remove the filter element.

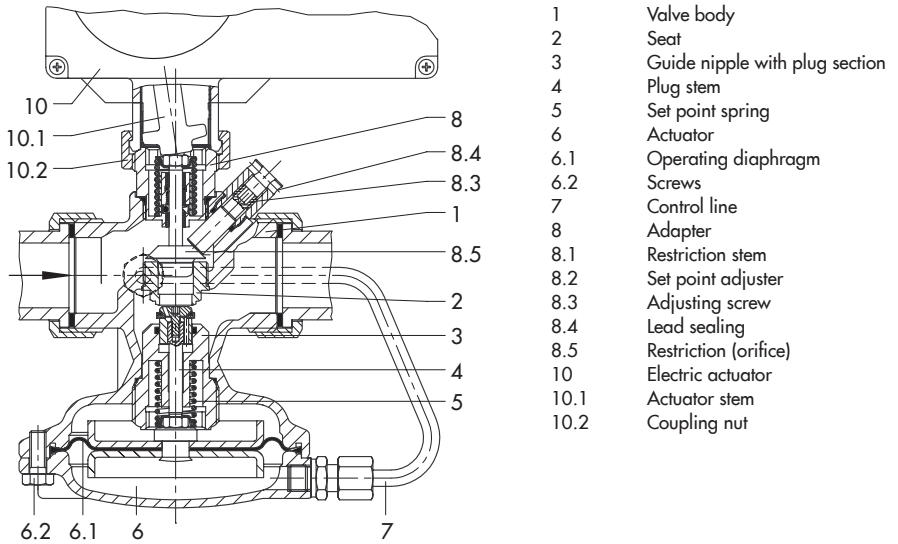

Valve DN 15 to 25, PN 25

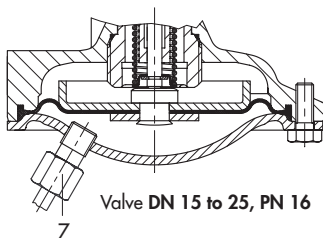

Valve DN 15 to 25, PN 16

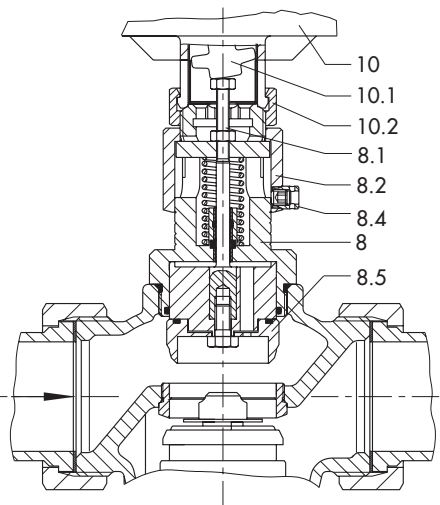

Valve DN 32 to 50

Tightening torques

Coupling nut (10.2)	DN 15 to 50	20 Nm
	DN 15 to 25	70 Nm
Guide nipple (3)	DN 32 to 50	110 Nm
	DN 15 to 25	8 Nm
Screws (6.2)	DN 15 to 25	8 Nm
	DN 32 to 50	18 Nm
Adapter (8)	DN 15 to 25	80 Nm
	DN 32 to 50	110 Nm

Fig. 1: Functional diagrams

4.3 Additional installation instructions

We recommend installing hand-operated shut-off valves both upstream of the strainer and downstream of the regulator. This allows the plant to be shut down for cleaning the strainer or working on the regulator.

Install a pressure gauge both upstream and downstream of the regulator to monitor the pressures prevailing in the plant.

5 Operation

See Fig. 1 on page 7.

5.1 Start-up

Before starting up or pressurizing the regulator, make sure the restriction (8.5) used to limit the flow rate is open.

To open the restriction, retract the actuator stem of the electric actuator using the manual override or by applying an electrical control signal.



WARNING!

Before removing the electric actuator from the valve, disconnect the power supply and protect it against inadvertent reconnection.

To open the restriction, de-energize electric actuators with fail-safe action and remove them from the valve.



NOTICE

When performing a pressure test on the plant with an installed regulator, make sure the diaphragm actuator

cannot be damaged by the test pressure (observe the maximum permissible differential pressure Δp).

Protect the regulator from icing up when controlling media that can freeze.

Fill the plant very slowly with the process medium on start-up.

5.2 Set point adjustment

The flow rate can be adjusted either when the electric actuator is mounted on the valve or without a mounted electric actuator.

5.2.1 Adjustment without actuator

For valve sizes DN 15 to 25, adjust the flow rate by turning the adjusting screw (8.3) at the side using a 4 mm hex wrench.

For valve sizes DN 32 to 50, use the set point adjuster (8.2) to adjust the flow rate.



NOTICE

For valve sizes DN 15 to 25, use the SAMSON manual adjustment tool (order no. 1790-8169) to close the restriction. Do not use the side adjusting screw (8.3) to close the restriction. To adjust the set point, remove the manual adjustment tool and use the adjusting screw.

1. Close the restriction by turning the set point adjuster (8.2) or manual adjustment tool clockwise. For valve sizes DN 15 to 25, the regulator is delivered with a closed restriction (8.5).

2. Determine the number of turns of the screw or adjuster required to achieve the desired flow set point from the relevant adjustment diagram. (For valve size DN 15, the adjustment curve that corresponds with the flow coefficient K_{VS} indicated on the nameplate must be selected).
3. Based on a closed restriction (screw/adjuster turned clockwise as far it will go), adjust the flow set point by turning the screw or adjuster counterclockwise. Check the flow rate and correct it, if necessary.
4. Secure the setting by inserting the wire for lead sealing through the lead-seal hole.

Table 1: K_{VS} coefficients and flow rates

Nominal size	DN 15				DN 20	DN 25	DN 32	DN 40 ¹⁾	DN 50 ¹⁾
K_{VS} coefficient	0.4	1	2.5	4	6.3	8	12.5	16/20 ²⁾	16/25 ²⁾
Set point range in m ³ /h with a differential pressure at the restriction $\Delta p_{\text{restriction}} = 0.2$ bar	-			0.6 to 1.3 ³⁾	0.8 to 2.3 ³⁾	0.8 to 3.5 ³⁾	2 to 5.8 ³⁾	3 to 9.1 ³⁾	4 to 14.1 ³⁾
	0.03 to 0.2	0.1 to 0.64	0.2 to 1.2	0.6 to 2.5	0.8 to 3.6	0.8 to 4.2 ⁴⁾	2 to 10	3 to 12.5	4 to 15

¹⁾ Also available as version with flanged body

²⁾ K_{VS} for flanged body

³⁾ A higher noise level will occur if the specified set point values are exceeded

⁴⁾ 5 m³/h with differential pressure at the restriction $\Delta p_{\text{restriction}} = 0.3$ bar (special version)

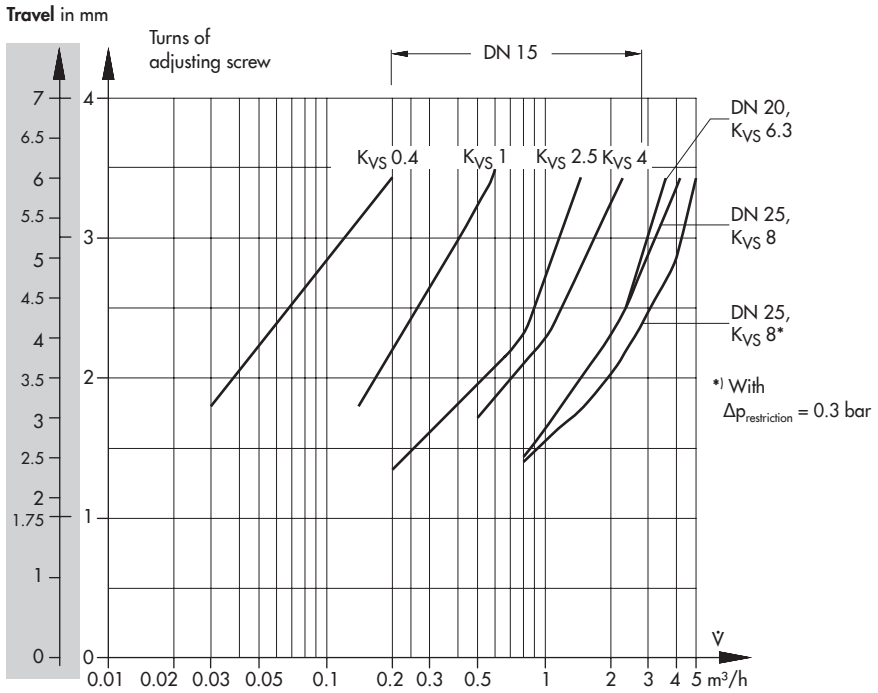
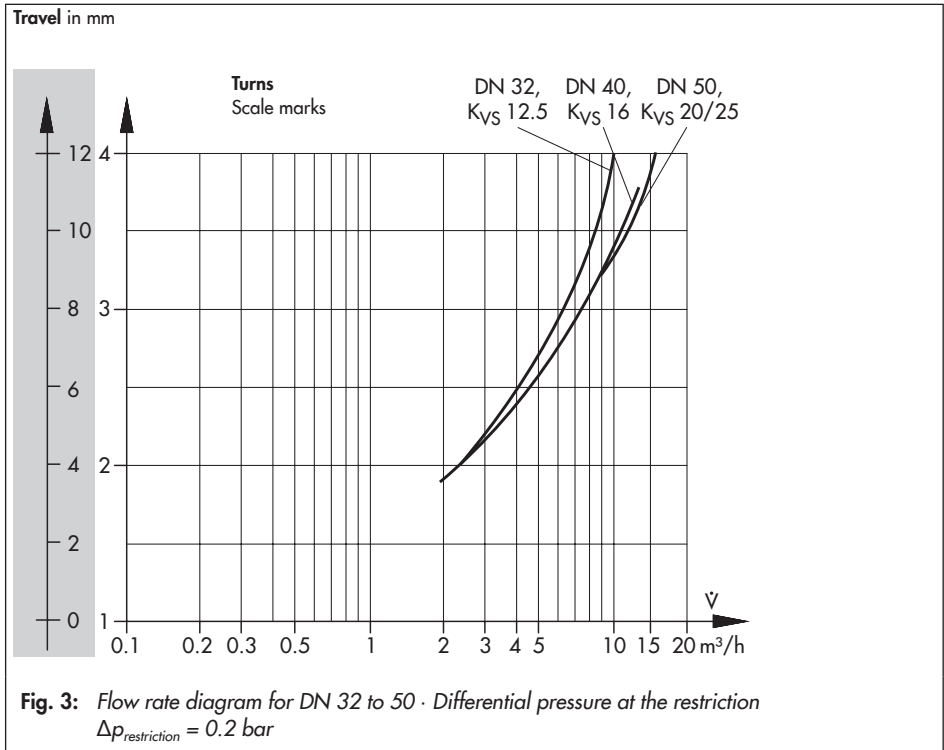

Fig. 2: Flow rate diagram for DN 15 to 25 · Differential pressure at the restriction $\Delta p_{\text{restriction}} = 0.2 \text{ bar}$



5.2.2 Adjustment with electric actuator



WARNING!

Electric actuators are designed for used in power installations. For wiring and maintenance, you are required to observe the relevant safety regulations. Take necessary measures to ensure that the power supply cannot be reconnected inadvertently. Take care while performing adjustment work on live parts. Never remove any covers.

5.2.3 Adjustment with Type 5857 or Type 5824 Actuator

1. Retract the actuator stem by turning the handwheel counterclockwise or by applying a corresponding control signal from the control device.
2. Proceed as described in section 5.2.1.

5.2.4 Adjustment with Type 5825 Actuator

1. Switch the control device to manual mode and change the control signal to retract the actuator stem all the way and compress the spring mechanism.

If there is no control signal, the actuator can be adjusted manually. For manual adjustment, remove the front case cover. Place a 4 mm hex wrench on the red actuating shaft and turn it. Only turn the shaft counterclockwise and only up to the point at which the torque switch in the actuator is activated.

Once the magnet has been released, the spring mechanism pushes the actuator stem back to the fail-safe position.



WARNING!

Observe the relevant safety regulations on connecting the electric actuator or performing any maintenance on it.

2. Proceed as described in section 5.2.1 on page 8.



Note:

The flow rate indicated in the diagram is reduced by approximately 20 % for valves in sizes DN 32 to 50 which are combined with Type 5821/5822 Actuators.

6 Maintenance – Replacing parts

See Fig. 1 on page 7.

The flow regulator does not require any maintenance. Nevertheless, it is subject to natural wear, particularly at the seat, plug and operating diaphragm. Depending on the operating conditions that prevail, inspect the regulator at regular intervals to avoid possible malfunctions.



NOTICE

Prior to carrying out any maintenance work on the flow regulator, it must be removed from the pipeline. Before performing any work on the regulator, make sure the relevant section of the plant has been depressurized and, depending on the process medium, drained as well. Depending on the field of application, allow the regulator to cool down or warm up to reach ambient temperature prior to starting any work on it.

If the valve does not close tightly, this may be caused by a dirty seat and plug or due to wear.

If the flow rate deviates considerably from the adjusted set point, e.g. rapidly increasing flow rate, check the operating diaphragm for ruptures and replace it, if necessary.



WARNING!

Before removing the electric actuator from the valve, disconnect the power supply and protect it against inadvertent reconnection.

6.1 Replacing the restriction

1. Unscrew the coupling nut (10.2). Remove the actuator from the connecting part of the valve.



NOTICE

For valve sizes DN 15 to 25: Unscrew the adjusting screw (8.3) before removing the adapter.

2. Use a socket wrench (order no. 1280-3001, refer to section 6.2 on page 13) to unscrew the adapter (8) of the restriction and pull it out of the valve body.
3. Replace parts and reassemble in reverse order. Observe the tightening torques specified in the table in Fig. 1.

6.2 Cleaning or replacing the plug

1. Unscrew the coupling nut. Remove the actuator from the connecting part of the valve.
2. Unscrew the control line (7).
3. Unscrew the screws (6.2). Remove the bottom diaphragm case together with the

operating diaphragm (6.1) and diaphragm plate.

4. For valve sizes DN 15 to 25, unscrew the guide nipple with plug section (3) using a socket wrench (order no. 1280-3001) or a self-made wrench made from a Gedore screwdriver bit (IN 19-19), for example, by drilling a 17 mm hole with a 17 mm diameter into the 19 mm hexagon bit (Fig. 4). Pull out the guide nipple. For valve sizes DN 32 to 50, unscrew the stopper first and pull out the plug section.

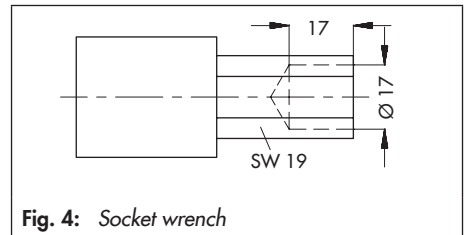

Fig. 4: Socket wrench

5. Thoroughly clean the seat and plug. Check the control line and screw fitting for any blockages.

If the plug is damaged, replace the entire plug section with a new one.

6. To reassemble, proceed in reverse order. Observe the tightening torques specified in the table in Fig. 1.

6.3 Replacing the diaphragm

1. Unscrew the coupling nut. Remove the actuator from the connecting part of the valve.
2. Unscrew the control line (7).
3. Unscrew the screws (6.2). Remove the bottom diaphragm case together with the operating diaphragm (6.1) and diaphragm plate.
4. Replace the diaphragm together with the diaphragm plates with new ones.
5. To reassemble, proceed in reverse order. Observe the tightening torques specified in the table in *Fig. 1*.

Prior to refastening the actuator, make sure that the diaphragm has been inserted properly into the ring groove.

7 Troubleshooting

Table 2: *Troubleshooting*

Fault	Possible reasons	Recommended action
Flow rate exceeds adjusted set point	Leak between seat and plug	Remove valve. Clean seat and plug. If necessary, replace plug (section 6.2). Otherwise, return device to SAMSON for repair.
	Defective operating diaphragm	Replace diaphragm (section 6.3) or return device to SAMSON for repair.
	Control line blocked	Remove and clean the control line.
	Valve too large for control task	Recalculate K_{VS} and contact SAMSON.
Flow set point not reached	Incorrect set point range selected	Check set point range and contact SAMSON.
	Safety device, e.g. pressure regulator, has been triggered	Check plant. Unlock safety device.
	Stem of electric actuator extended	Check control signal issued by the electric control device.
	Insufficient pressure drop across the plant	Compare differential pressure in the plant with the plant's drag. Min. diff. pressure $\Delta p_{\min} = \text{Differential pressure at the restriction } \Delta p_{\text{restriction}} + (\dot{V}/K_{VS})^2$
	Strainer blocked	Drain and clean filter of the strainer.
Incorrectly installed valve	Re-install valve such that direction of flow corresponds to arrow on the valve body.	
Control loop hunts	Valve too large for control task	Recalculate K_{VS} and contact SAMSON.

8 Nameplate

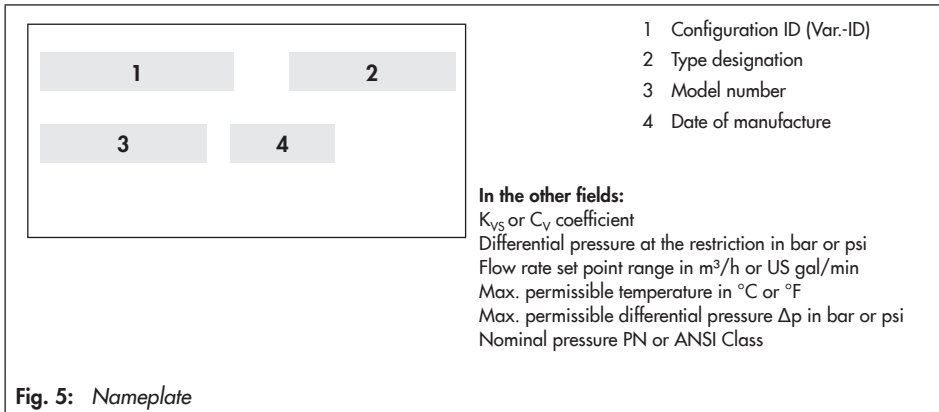

9 Customer service

If malfunctions or defects occur, contact the SAMSON After-sales Service department for support.

E-mail address: aftersalesservice@samson.de

The addresses of SAMSON AG, its subsidiaries, representatives and service facilities worldwide can be found on the SAMSON website, in all SAMSON product catalogs or on the back of these Mounting and Operating Instructions.

To assist diagnosis and in case of an unclear mounting situation, specify the following details (see section 8):

- Type designation (valve, actuator) and nominal size of the valve
- Model number and configuration ID (Var.-ID)
- Upstream and downstream pressure
- Process medium and its temperature
- Min. and max. flow rate
- Is a strainer installed?
- Installation drawing showing the exact location of the regulator and all the additionally installed components (shut-off valves, pressure gauge, etc.)

Nameplates are attached to the valve and the actuator.

10 Dimensions

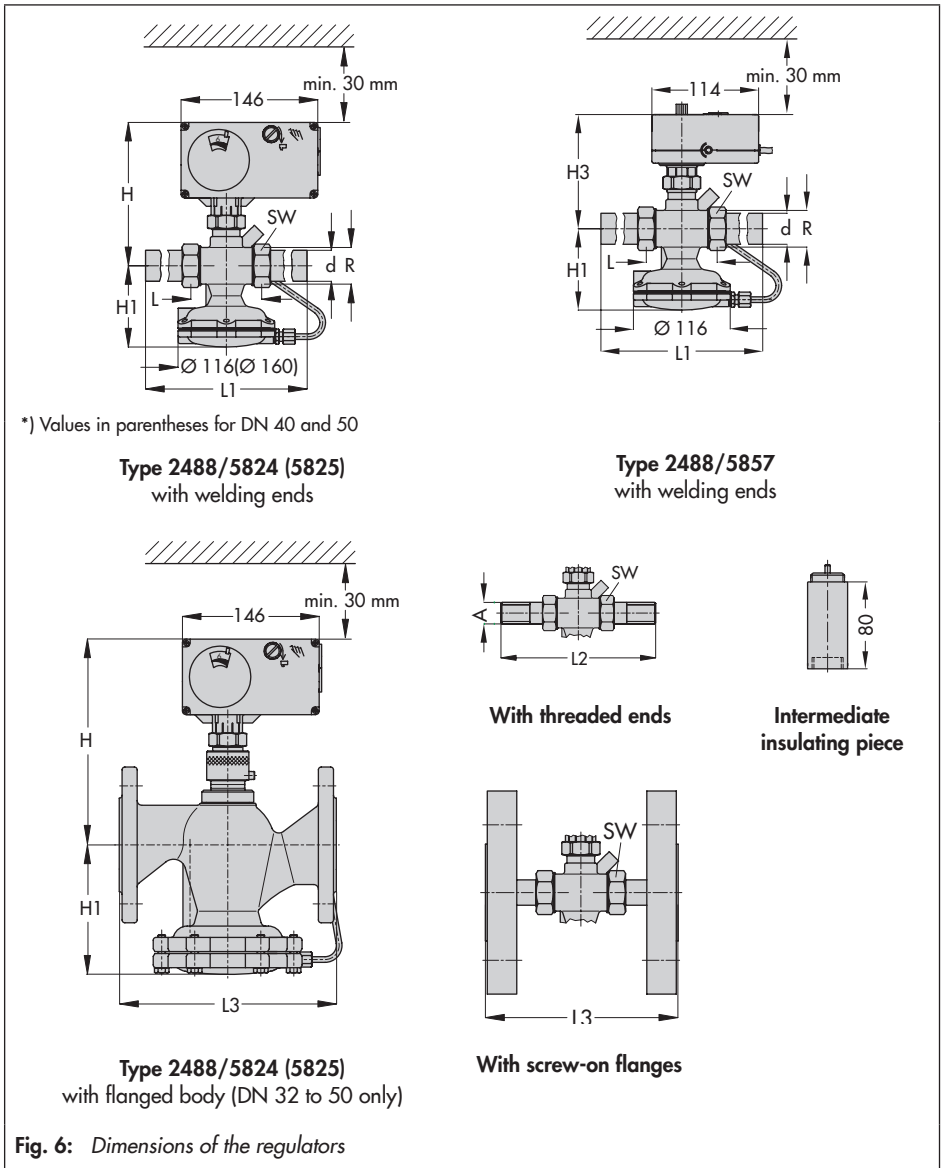

Table 3: *Dimensions and weights*

Nominal size	DN 15	DN 20	DN 25	DN 32 ¹⁾	DN 40 ¹⁾	DN 50 ¹⁾
Pipe Ø d	21.3 mm	26.9 mm	33.7 mm	42.4 mm	48.3 mm	60.4 mm
Thread size R	G ¾	G 1	G 1¼	G 1¾	G 2	G 2½
Width across flats SW	30 mm	36 mm	46 mm	59 mm	65 mm	82 mm
Length L	65 mm	70 mm	75 mm	100 mm	110 mm	130 mm
Height H	155 mm			216 mm		
Height H3	122 mm			-		
Height H1	85 mm			105 mm	140 mm	
Version with welding ends						
Length L1	210 mm	234 mm	244 mm	268 mm	294 mm	330 mm
Weight	3.0 kg	3.1 kg	3.2 kg	4.4 kg	6.9 kg	7.4 kg
Special versions						
With threaded ends						
Length L2	129 mm	144 mm	159 mm	192 mm	206 mm	228 mm
Male thread A	G ½	G ¾	G 1	G 1¼	G 1½	G 2
Weight	3.0 kg	3.1 kg	3.2 kg	4.4 kg	6.9 kg	7.4 kg
With screwed-on flanges²⁾ (PN 16/25) or with flanged body (DN 32 to 50)						
Length L3	130 mm	150 mm	160 mm	180 mm	200 mm	230 mm
Weight	4.4 kg	5.1 kg	5.7 kg	7.6 kg	10.9 kg	12.4 kg

¹⁾ Additional version: Valve with flanged body

²⁾ Flanges are already mounted on valves in DN 40 and 50

11 Technical data

Table 4: *Technical data · Valve*

Nominal size		DN 15/20/25			DN 15	DN 20	DN 25	DN 32 ²⁾	DN 40 ²⁾	DN 50 ²⁾	
K _{VS}	Body with screwed ends	0.4 ¹⁾	1 ¹⁾	2.5	4 ¹⁾	6.3	8	12.5	16	20	
	Flanged body	–						12.5	20	25	
x _{FZ} value	Body with screwed ends	0.6						0.5		0.45	
	Flanged body	–						0.45		0.4	
Nominal pressure		PN 16/PN 25						PN 25			
Max. perm. diff. pressure Δp across the valve		10 ³⁾ /20 bar						16 bar			
Max. perm. temperature		For liquids 130 °C (PN 16)/150 °C ⁴⁾ (PN 25) · For air and non-flammable gases 80 °C									
Compliance											

1) Special version

2) Additional version: Valve with flanged body made of spheroidal graphite iron (EN-JS1049)

3) For PN 16 version

4) With intermediate insulating piece (item no. 1992-3132)

Table 5: Technical data · Electric actuators

Electric actuator		Type 5824-.../ TROVIS 5724-... ¹⁾		Type 5825-.../ TROVIS 5725-.../ TROVIS 5725-7 ¹⁾		TROVIS 5757-3 TROVIS 5757-7 ¹⁾	Type 5857
		Without fail-safe action		With fail-safe action		Without fail-safe action	
		10	20	10	20	–	
Rated travel	DN 15 to 25	6 mm	–	6 mm	–	6 mm	
	DN 32 to 50	–	12 mm	–	12 mm	–	
Transit time for rated travel		35 s ²⁾	70 s ²⁾	35 s ²⁾	70 s ²⁾	20 s	
Transit time for fail-safe action		–		4 s	8 s	–	
Actuating force		700 N		–		300 N	
Nominal thrust of safety spring		–		500 N		–	
Power supply		230 V, 50 Hz (24 V, 50/60 Hz; 24 V DC)					
Power consumption		Approx. 3 VA		Approx. 3 VA +1 VA		Approx. 3 VA	
Manual override		Yes		Possible ³⁾		Yes	
Permissible ambient temperature		0 to +50 °C					
Perm. temperature at the connecting stem		0 to +130 °C/150 °C ⁴⁾				0 to +120 °C/150 °C ⁴⁾	
Degree of protection (installed upright, according to EN 60529)		IP 54				IP 42	
Compliance							
Data sheets		T 5724/T 5725-7				T 5757/ T 5757-7	T 5857

¹⁾ TROVIS 57xx only with 230 V/50 Hz

²⁾ Shorter transit times on request

³⁾ Manual override using 4 mm Allen key (after removing the cover); actuator always returns to fail-safe position after release.

⁴⁾ With intermediate insulating piece (item no. 1992-3132)



SAMSON AG · MESS- UND REGELTECHNIK
Weismüllerstraße 3 · 60314 Frankfurt am Main, Germany
Phone: +49 69 4009-0 · Fax: +49 69 4009-1507
samson@samson.de · www.samson.de

EB 3135-1 EN

2016-11-29 · English