



Fig. 1

1. General

 Assembly, start-up and operation of the device may only be performed by trained and experienced personnel familiar with this product.

According to these mounting and operating instructions, trained personnel refers to individuals who are able to judge the work they are assigned to and recognize possible dangers due to their specialized training, their knowledge and experience as well as their knowledge of the applicable standards.

Explosion-protected versions of this device may only be operated by personnel who have undergone special training or instructions or who are authorized to work on explosion-protected devices in hazardous areas.

Any hazards which could be caused in the control valve by the process medium, the operating pressure, the signal pressure or the moving parts are to be prevented by means of the appropriate measures.

The maximum permissible supply pressure may not be exceeded and must be limited by a supply pressure regulator, if necessary.

If inadmissible motions or forces are produced in the pneumatic actuator as a result of the supply air pressure level, it must be restricted by means of a suitable supply pressure reducing station.

Proper shipping and appropriate storage are assumed.

The solenoid valves may be mounted in any required position. The filter in the enclosure cover and the cable gland M20 x 1.5 must be mounted to face downwards or, in cases where this is not possible, mounted horizontally.

On mounting the solenoid valve, make sure that ≥ 300 mm clearance is kept above the enclosure cover.

Contents	Page
1. General	1
2. Attachment	2
3. Pneumatic connection	4
4. Electrical connection	5
5. Certificates	6

If the solenoid valve is to be attached to rotary or linear actuators with a mounted positioner, the external air supply must be used connected over port **9**.

The lowest permissible ambient temperature is $-20\text{ }^{\circ}\text{C}$ for Types 3701-xxxx xxxx 0 and $-45\text{ }^{\circ}\text{C}$ for Types 3701-xxxx xxxx 2.

The permissible ambient temperature range is lower for intrinsically safe devices according to the EC Type Examination Certificate PTB 01 ATEX 2178 and the Statement of Conformity PTB 02 ATEX 2014 X. Refer to pages 6 and 7 for more details.

Refer to Data Sheet T 3701 EN for technical data, ordering details, spare parts and accessories.

2. Attachment

Attachment to linear actuators

The Type 3701-xxx1 Solenoid Valve is designed for attachment according to IEC 60534-6 (NAMUR) and is attached directly to the yoke of the control valve with a M8 fastening screw (1) after the enclosure cover has been removed. Slide the washer and O-ring over the screw before fastening it.

For Series 240 Valves in DN 15 to 80 equipped with positioners or limit switches, an additional distance piece (2) is required. Distance piece and screw M8 x 90:

Order no. 1400-5905

For valves with rod-type yokes 18 to 35 mm, the solenoid valve is attached over a support (3) with clamping plate (4)

Order no. 1400-5342.

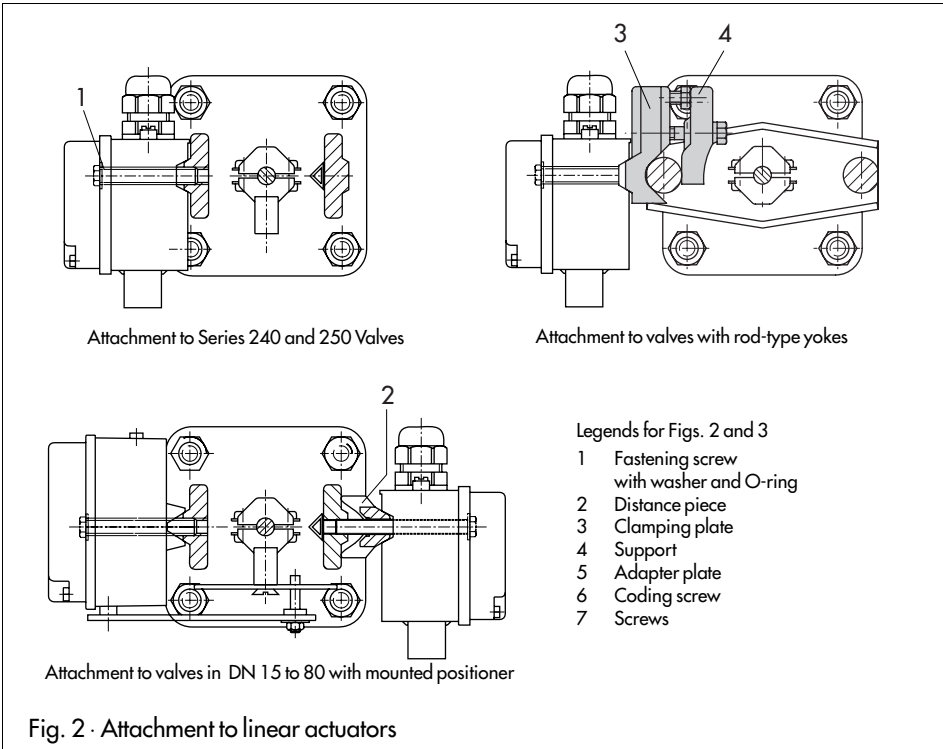

Attachment to rotary actuators

Version for adapter plate

The Type 3701-xxx2 Solenoid Valve is equipped in this version with bores for the output signal (1.3 and 2.3) at the back. An adapter plate (5) for the attachment and connection according to VDI/VDE 3845 is required on site (adapter plate with order no. 1400-5235).

The adapter plate is included in the scope of delivery for Type 3701-xxx0.

Mount first the adapter plate onto the NAMUR interface of the actuator. Prior to

mounting, check to make sure the two O-rings are positioned correctly.

The operating direction is determined by a coding screw (6) M5 x 10 DIN 916 inserted in the connecting flange of the rotary actuator.

Two screws (7) M5 x 16 (DIN 912) are used to mount the adapter plate.

The mounting accessories are included in the scope of delivery.

Following this, mount the solenoid valve onto the adapter plate using the M8 screw with washer and O-ring. Check beforehand whether the two O-rings are positioned correctly in their recesses.

Mounting accessories

Screw (1) with washer and O-ring for the positioner:

Order no. 1400-5991

Note!

After mounting the solenoid valve, make sure that the vent plug located in the enclosure cover faces downwards when the control valve is mounted, or in cases where this is not possible, the vent plug must be positioned horizontally.

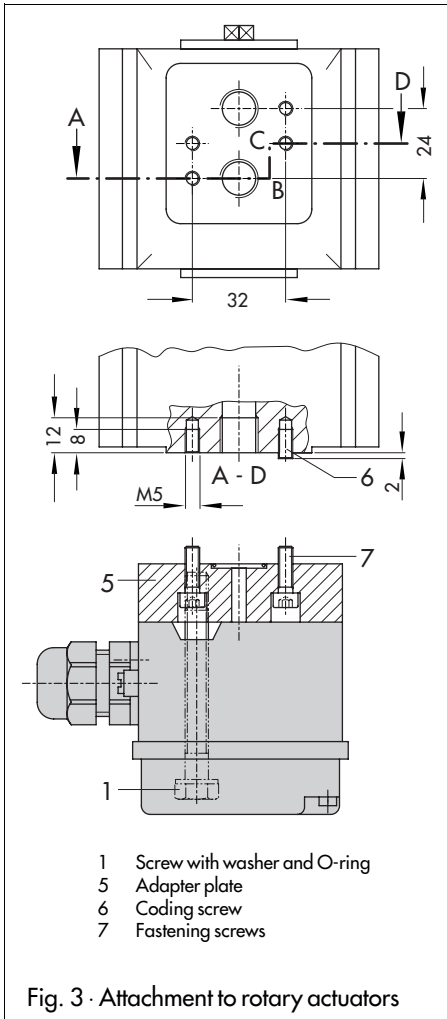

Fig. 3 · Attachment to rotary actuators

3. Pneumatic connection



Attach and route connection lines and screw fittings properly.

Check them regularly for any leaks or damage and, if necessary, repair them.

Prior to performing any repair work, relieve the connection line of pressure.

The supply air is connected over threaded bores with G 1/4 or 1/4 NPT depending on the version.

Note: The K_{vs} coefficient of an upstream supply pressure regulator must be at least 1.6 times higher than the K_{vs} coefficient.

Connection line

Refer to the table below for the minimum required nominal size of the connection line at the port **4** of the enclosure.

The specifications apply to a connection line length ≤ 2 m. Use a larger nominal size for a connection line length ≥ 2 m.

Pressure [bar]	Nominal size	K_{vs}
≥ 1.4	≥ 6	0.25
≥ 2.5	≥ 4	
≥ 6		

Operating medium for the booster valve

The internal supply air is connected over port **4** (delivery status):

Instrument air, free of corrosive components, between 1.4 and 6 bar.

The external supply air is connected over port **9**:

Instrument air, free of corrosive components, lubricated air and non-corrosive gases, between 0 and 6 bar.

Supply air for the pilot valve

Instrument air, free of corrosive components, between 1.4 and 6 bar.

Ambient temperature [°C]	Particle size [μm]	Pressure dew point [°C]	Oil content [mg/m^3]
+15...+35	≤ 5	+10	≤ 0.1
-15		-20	
-32		-40	
-60		-70	

Changeover to external air supply connected over port **9**

The solenoid valve is delivered with the internal air supply connected over port **4**.

Convert to the external air supply connected over port **9** as follows:

Open the cover of the solenoid valve and unthread screw on turnboard.

Turn the turnboard by 90° . The arrow must point to **9**. Refasten screw.

4. Electrical connection



As far as the electrical installation of the device is concerned, the relevant national regulations governing the installation of electrical equipment and the national accident prevention regulations of the country of destination must be adhered to. In Germany, these are the VDE regulations and accident prevention regulations of the employer's liability insurance.

The required degree of protection to comply with IEC 60529 (2001) is only guaranteed when the enclosure cover is mounted, the exhaust air filters are installed and the electrical wiring has been connected correctly.

For installation in hazardous areas, the following standards apply: EN 60079-14: 2003 (VDE 0165 Part 1) "Electrical apparatus for explosive gas atmospheres" and EN 50281-1-2: 1999 (VDE 0165

Part 2) "Electrical apparatus for use in the presence of combustibile dust".
For intrinsically safe electrical apparatus that are certified according to the Directive 79/196/EEC, the data specified in the certificate of conformity apply for connection of intrinsically safe circuits.
For intrinsically safe electrical apparatus that are certified according to the Directive 94/9/EC, the data specified in the EC Type examination certificate apply for connection of intrinsically safe circuits.

The electrical supply is connected over a cable gland M20 x 1.5 to terminals in the enclosure or with a connector.

Connecting lead

We recommend using connecting leads with a wire cross-section of $\geq 0.5 \text{ mm}^2$. Connecting leads with an outer diameter between 6 and 12 mm are suitable for M20 x 1.5 cable glands.

Degree of protection

Devices with degree of protection IP 54 can be upgraded to degree of protection IP 65 by exchanging the filter in the enclosure cover.

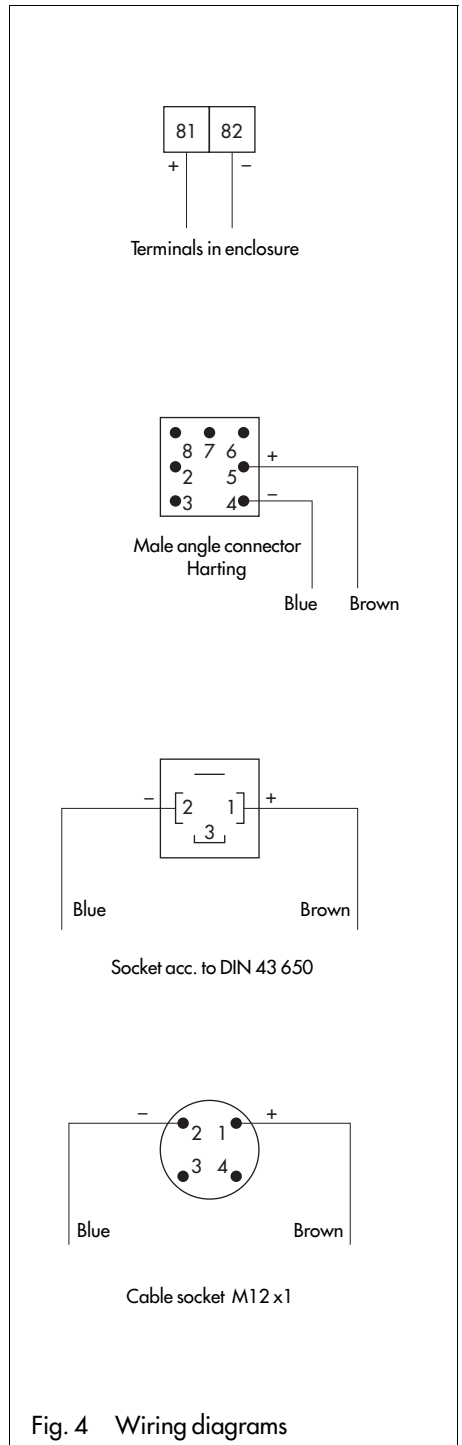

Fig. 4 Wiring diagrams

5. Certificates

EC Type Examination Certificates PTB 01 ATEX 2178 dated 2001-11-29 (excerpt)
for Type 3701-1x Solenoid Valve

⊕ II 2 G EEx ia IIC T6/II 2 D IP 65 T 80 °C

For use in Zone 1 and Zone 21

The correlation between version, temperature classification, permissible ambient temperature ranges and maximum power dissipation is shown in the table below:

Type		3701-11	3701-12	3701-13
Nominal signal	U_N	6 V DC	12 V DC	24 V DC
Ambient temperature ¹⁾		-45 to +60 °C (Temperature class T6) -45 to +70 °C (Temperature class T5) -45 to +80 °C (Temperature class T4)		
Power dissipation	P_i	250 mW	No restriction	
Internal inductance	L_i	Negligible		
Internal capacitance	C_i	Negligible		

¹⁾ The materials used for the filter and cable gland restrict the minimum permissible ambient temperature to -20 °C in Type 3701-1xxx xxx0.

The maximum values for connection to a certified intrinsically safe is shown in the table below:

Voltage	U_i	25 V	27 V	28 V	30 V	32 V
Current	I_i	150 mA	125 mA	115 mA	100 mA	85 mA

Note: The EC Type Examination Certificate is available on request.

Model number and modification index

The model number and modification index are specified on the nameplate:

3701-xxxx xxxx xxxx x

Model number

Modification index

**Statement of Conformity PTB 02 ATEX 2014 X dated 2002-03-07 (excerpt)
for Type 3701-8x Solenoid Valve (modification index 13 and higher)**

⊕ II 3 G EEx nA II T6 / II 3 D IP 65 T 80 °C

For use in Zone 2 and Zone 22

The correlation between the version and temperature classification is shown in the table below:

Type		3701-81	3701-82	3701-83
Nominal signal	U _N	6 V DC	12 V DC	24 V DC
Ambient temperature ¹⁾		-45 to +60 °C (Temperature class T6) -45 to +70 °C (Temperature class T5) -45 to +80 °C (Temperature class T4)		

¹⁾ The materials used for the filter and cable gland restrict the minimum permissible ambient temperature to -20 °C in Type 3701-8xxx xxxx 0.

Special conditions

The required degree of protection IP 54 according to IEC 60529 (2001) is only guaranteed when the enclosure cover is installed properly and the electrical wiring is connected correctly.

The wiring shall be connected in such a manner that the connection facilities are not subjected to tensile and/or torsional stress.

Model number and modification index

The model number and modification index are specified on the nameplate:

3701-xxxx xxxx xxxx x



Installation Manual for apparatus certified by CSA for use in hazardous locations.
 Electrical rating of intrinsically safe apparatus and apparatus for installation in hazardous locations.

Table 1: Maximum values of solenoid valve circuit

	UL or Vmax	IL or Imax	PI or Pmax	CI	LI
12V/24 V version	28V	115mA	no limited	0 nF	0 µH
6 V version	28V	115 mA	250mW	0 nF	0 µH

UL or V_{oc} ≤ UL or V_{max} / IL or I_{oc} ≤ IL or I_{max} / P_o ≤ P_i or P_{max}; C_o ≥ C_i and L_i ≥ L_o

Table 2: CSA - certified barrier parameters of solenoid valve circuit

Barrier	Supply barrier		Evaluation barrier	
	V _{max}	R _{in}	V _{max}	R _{in}
12V/24 V version	≤ 28V	≥ 240Ω	≤ 28V	≥ 240Ω
6 V version	≤ 28V	≥ 784Ω	28V	Diode Return

Table 3: The correlation between temperature classification and permissible ambient temperature ranges is shown in the table below:

Temperature class	Permissible ambient temperature range
T6	-45°C ... 60°C
T5	-45°C ... 70°C
T4	-45°C ... 80°C

Intrinsically safe if installed as specified in manufacturer's installation manual.

CSA- certified for hazardous locations

Ex Ia IIC T6; Class I, Zone 0

Class I; Groups A, B, C, D

Class II; Groups E, F + G; Class III

Type 3 Enclosure

Notes:

- The apparatus may be installed in intrinsically safe circuit only when used in conjunction with the CSA certified apparatus. For maximum values of UL or V_{max}; IL or I_{max}; P_i or P_{max}; C_i and L_i of the various apparatus see Table 1.
- The apparatus may be installed in intrinsically safe circuit only when used in conjunction with the CSA certified intrinsically safe barrier. For barrier selection see Table 2.
- Installations shall be in accordance with the Canadian Electrical Code Part. 1. Use only supply wires suitable for 5°C above surrounding temperature.

Revisions Control Number: 1 May 05

Addendum to EB 8375 EN

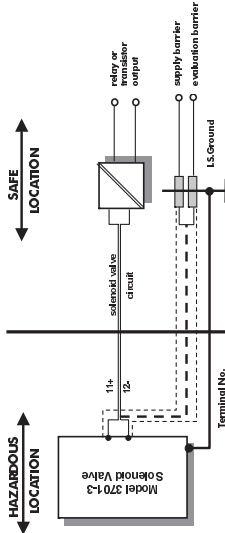

Version: Model 3701-3 solenoid valves.

Supply and evaluation barrier CSA- certified.

For the permissible maximum values for the intrinsically safe circuit see Table 1

For the permissible barrier parameters for the circuit see Table 2

Cable entry M 20 x 1.5 or metal conduit according to drawing No. 1050 - 0539 T or 1050 - 0540 T

CSA- certified for hazardous locations

Class I; Div. 2, Groups A, B, C, D,

Class II; Div. 2 Groups E, F + G; Class III.

Type 3 Enclosure

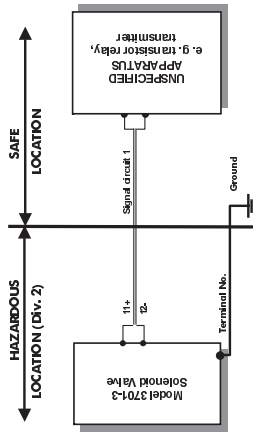

Notes:

- For the maximum values for the circuit see Table 1 and 2.
- Cable entry only rigid metal conduit according to drawing No. 1050-0539 T and 1050-0540 T

Revisions Control Number: 1 May 05

Addendum to EB 8375 EN

Installation Manual for apparatus approved by FM for use in hazardous locations.
 Electrical rating of intrinsically safe apparatus and apparatus for installation in hazardous locations.

Table 1: Maximum values

	U ₀ or V _{max}	I ₀ or I _{max}	P ₀ or P _{max}	C _i	L _i
Solenoid valve 12V/24 V version	28V	115mA	no limited	0nF	0 µH
Solenoid valve 6 V version	28V	115 mA	250mW	0nF	0 µH

Notes: U₀ or V₀ or V_i ≤ U₀ or V_{max} / I₀ or I₀ or I_i ≤ I₀ or I_{max}
 P₀ or P_{max} ≤ P₀ or P_{max}

Table 2: FM - approved barrier parameters of solenoid valve circuit

Barrier	Supply barrier			Evaluation barrier		
	V _{0c}	R _{min}	I _{0c}	V _{0c}	R _{min}	I _{0c}
Solenoid valve 12V/24 V version	≤ 28V	≥ 240Ω	≤ 115mA	≤ 28V	#	0mA
Solenoid valve 6 V version	≤ 28V	≥ 784Ω	≤ 115mA	28V	#	0mA

Table 3: The correlation between temperature classification and permissible ambient temperature ranges is shown in the table below:

Temperature class	Permissible ambient temperature range
T6	60°C
T5	-45°C ... 70°C
T4	80°C

Intrinsically safe if installed as specified in manufacturer's installation manual.

FM - approved for hazardous locations

Class I, Zone 0, A Ex in IEC T6

Class I, II, III Division 1, Groups A, B, C, D, E, F, + G

NEMA3R

Notes:

- 1.) The apparatus may be installed in intrinsically safe circuits only when used in conjunction with the FM approved apparatus. For maximum values of U₀ or V_{max}; I₀ or I_{max}; P₀ or P_{max}; C_i and L_i of the various apparatus see Table 1.
- 2.) The apparatus may be installed in intrinsically safe circuit only when used in conjunction with the FM approved intrinsically safe barrier. For barrier selection see Table 2.
- 3.) Installation shall be in accordance with the National Electrical Code ANSI/NFPA 70 and ANSI/ISA RP 12.06.01
- 4.) Use only supply wires suitable for 5°C above surrounding temperature.

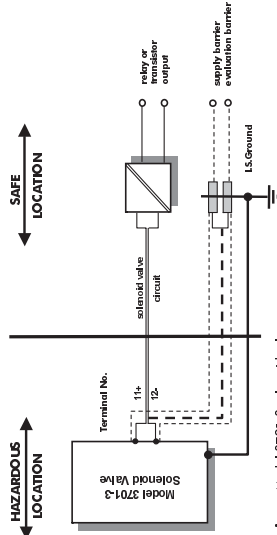

Version: Model 3701-3 solenoid valve.

Supply and evaluation barrier FM/CSA- approved.

For the permissible maximum values for the intrinsically safe circuit see Table 1

For the permissible barrier parameters for the circuit see Table 2

Cable entry M 20 x 1.5 or metal conduit according to drawing No. 1050 - 0539 T or 1050 - 0540 T

FM- approved for hazardous locations

Class I, Division 2, Groups A, B, C, D
Class I, Class II Division 2, Groups F + G, Class III

NEMA 3R

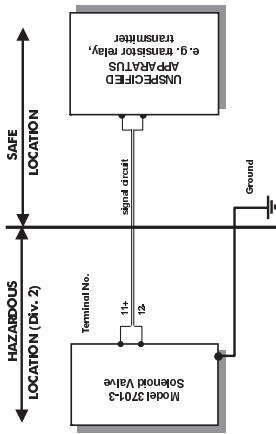

Notes:

- 1.) For the maximum values for the individual circuit see Table 1 and 2.
- 2.) Cable entry only rigid metal conduit according to drawing No. 105Q-0539 T and 105Q-0540 T
- 3.) The installation shall be in accordance with the National Electrical Code ANSI/NFPA 70



SAMSOMATIC GmbH

Weismüllerstraße 20-22 · 60314 Frankfurt /Main · Germany

Phone: +49 69 4009-0 · Fax: +49 69 4009-1644

Internet: <http://www.samsomatic.de>

EB 3701 EN