

Fig. 1

## Contents

<b>General notes</b>	2
<b>Mounting</b>	2
Mounting of devices without adapter plate	3
Mounting of devices with adapter plate	3
<b>Air connection</b>	4
Air supply for the pilot valve	4
Connecting data for the booster valve	4
<b>Electrical connection</b>	5
Connecting cables	5
Connecting diagram	5
Manual operation function/exhaust air filter	5
<b>Certifications</b>	6
EC-Type Examination Certificate PTB 98 ATEX 2047	6

## General notes



The devices may only be assembled, started up, and operated by experienced personnel familiar with this product. Proper shipping and appropriate storage of the devices are assumed.

In these Mounting and Operating Instructions, the term "experienced personnel" refers to persons, who are able to evaluate the responsibilities assigned to them as well as recognize potential hazards due to their specialized training, knowledge, and experience as well as their special knowledge of the relevant standards.

Staff handling/operating ex-proof devices in hazardous areas must be specially trained or instructed, i. e. authorized to handle/operate ex-proof devices.

For technical data, ordering data, spare parts and accessories, see Data Sheet T 964 EN.

## Mounting



Before mounting, all relevant parts of the plant must be depressurized. The enclosure must not be opened.

The devices can be mounted to Type 3756 Booster Valves (see Data Sheets T 756-1/5 EN and T 756-6 EN), Type 3994-0671 Diaphragm Valves (see Data Sheet T 994-0671 EN) and valves according to ISO 5999/1 with CNOMO interface. The relevant mounting instructions must be observed (see page 3).

The devices can be mounted in any desired position. The exhaust air filter at the enclosure must not be covered (see page 5, Fig. 5).

The cable socket must be installed so that the cable gland is vertically suspended or, if this is not possible, horizontally.

On mounting, it is important that a clearance of 300 mm minimum above the enclosure and 200 mm minimum at the electrical connection be observed.

## Mounting of devices without adapter plate

### ► Type 3964-XXXXX0000

Devices without adapter plate are mounted according to the notes of the manufacturer for the booster valve.

The mounting accessories are not delivered together with the device.

## Mounting of devices with adapter plate

### ► Type 3964-XXXX00X10

Devices with adapter plate without diaphragm switch are attached to the booster valve with two hexagon socket head screws ① and two split washers ② (see Fig. 2). Be sure to check that the two O-rings or seals at the CNOMO interface of the booster valve are positioned correctly.

The mounting accessories are delivered together with the device.

### ► Type 3964-XXXX00X1X

Devices with adapter plate and diaphragm switch are attached to the booster valve with two hexagon socket head screws ① and two split washers ② (see Fig. 3). Be sure to check that the two O-rings or seals at the CNOMO interface of the booster valve are positioned correctly.

The mounting accessories are delivered together with the device.

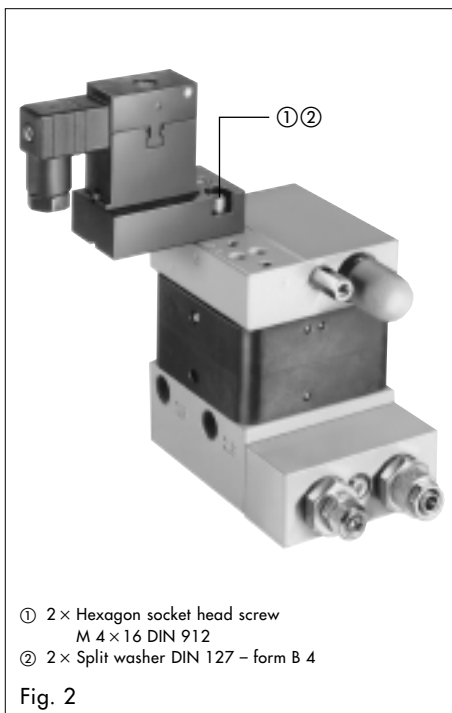

Fig. 2

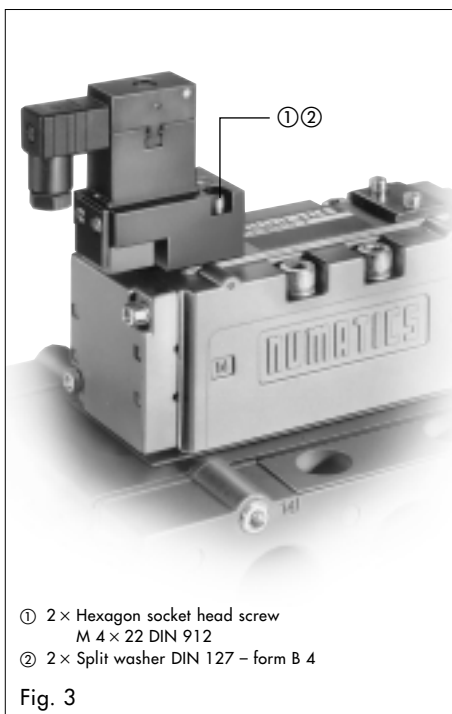

Fig. 3

## Air connection



At the booster valve, the air supply pipes and screw joints may only be laid and assembled by experienced personnel. They must be regularly checked for leaks and damage and, if necessary, repaired. Before starting any repair work, all supply pipes which are to be opened must be depressurized.

The air supply must not exceed the maximum permissible pressure.

The air supply is connected via the CNOMO interface on the booster valve (see table "Air supply for the pilot valve").

The air connections are on the booster valve (see table "Connecting data for the booster valve").

Air supply for the pilot valve			
Instrument air 1.4 ... 3.5 bar			
Ambient-temperature (°C)	Dew point (°C)	Particle size (µm)	Oily residues (mg/m <sup>3</sup> )
+15 ... +35	+10	≤ 5	≤ 0.1
-15	-20		
-32	-40		
-60	-70		

Connecting data for the booster valve			
Version	Pressure	Connection	Nominal size
Type 3756 Line-up Booster Valves without pressure reducer	1.4 ... 1.6 bar	8	DN 4
with pressure reducer	1.6 ... 6.0 bar	9	DN 8 (up to 4 functions) DN 10 (up to 8 functions) DN 12 (up to 12 functions)
Type 3756 Booster Valves -X403/-X404 *) -X413/-X414 *)	1.4 ... 3.0 bar	9 4	DN 4 DN 10
-X405/-X406 -X407/-X408 -X52X/-X53X -X54X/-X55X	1.4 ... 3.5 bar	9/12/14	DN 6
Type 3994-0671 Diaphragm Valves	max. 3.0 bar	9	DN 4
Valves according to ISO 5599/1	max. 3.5 bar **)	see notes of the manufacturer	

\*) Only for Type 3964-XXXX00X11/-XXXX00X12 Pilot Valves with diaphragm switch

\*\*) For minimum pressure see notes of the manufacturer

## Electrical connection



As far as the electrical installation of the device is concerned, the relevant electrotechnical regulations and the accident prevention regulations of the country in which the device is used must be observed. In Germany these are the VDE regulations and the accident prevention regulations of the employers' liability insurance association.

For mounting in hazardous areas, the respective national regulations of the country in which the device is used applies. In Germany this is VDE 0165.

For connection to certified intrinsically safe electric circuits, the EC-Type Examination Certificate PTB 98 ATEX 2047 applies (see page 6). When connected to DC voltage signals, correct polarity must be ensured.

The enclosure must not be opened.

### Connecting cables

The power supply is connected with a plug-type connector according to DIN 43 650, form C (contact clearance 8 mm) or a plug-type connector according to industrial standard, form C (contact clearance 9.4 mm).

It is recommended that connecting cables with a conductor cross-section of minimum 0.5 mm<sup>2</sup> and an external diameter of 3.5 to 6 mm are used.

To guarantee the protection class, the cable socket must be installed with a flat gasket placed underneath.

### Manual operation function/exhaust air filter



For safety circuits, only pilot valves without manual operation function should be used.

The pilot valve is optionally provided with a manual operation function ① (see Fig. 5). When a nominal signal is not available, the pilot valve can be operated by a pushbutton or a pushbutton switch using a screw driver (screw driver point 4.5 mm).

Aeration ensues via an exhaust air filter ② at the enclosure. To guarantee a safe function, the exhaust air filter must not be covered.

### Connecting diagram

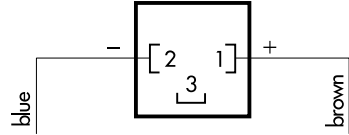
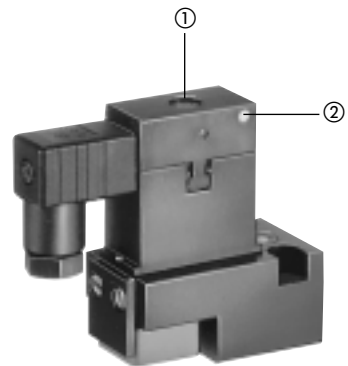

Fig. 4

### Manual operation function/ exhaust air filter



- ① Manual operation function
- ② Exhaust air filter

Fig. 5

## Certifications

EC-Type Examination Certificate  
PTB 98 ATEX 2047



II 2 G EEx ia IIC T6

The following table shows the permissible ambient temperature within the temperature classes:

Temperature class	T 6	T 5	T 4
Ambient temperature	-20 ... +60 °C	-20 ... +70 °C	-20 ... +80 °C

For connection to a certified intrinsically safe electric circuit, the maximum permissible values for input voltage  $U_i$ , input current  $I_i$ , input power  $P_i$ , internal inductance  $L_i$  and internal capacitance  $C_i$  are shown in the following table:

$U_i$	25 V	27 V	28 V	30 V	32 V
$I_i$	150 mA	125 mA	115 mA	100 mA	90 mA
$P_i$	no power limit				
$L_i$	negligible				
$C_i$	negligible				

**Note:** The EC-Type Examination Certificate is available on request

(Specifications subject to change without notice)

---

**SAMSOMATIC**  
AUTOMATIONSSYSTEME  
GMBH

- A subsidiary of SAMSON AG

Weismüllerstrasse 20-22  
D-60314 Frankfurt am Main  
P. O. Box 101901  
D-60019 Frankfurt am Main  
Telephone +49-69-40090  
Telefax +49-69-4009644

A.