



Figure 1 · TROVIS 5430

Contents	Page
1. General	4
1.1 Notes for the user	4
1.2 Technical data	5
1.3 Resistance values of sensors	6
2. Installation	7
2.1 Installing the controller	7
2.2 Installing the sensors	8
3. Electrical connections	8
3.1 General notes	8
3.2 Connecting the controller	8
3.3 Connecting the sensors	8
3.4 Connecting the actuator	9
3.5 Connecting the pumps	9
3.6 Terminal connection diagrams	9
4. Description of controller functions	11
4.1 Optimizing	11
4.2 Flash adaptation	12
4.3 Reduced operation	12
4.4 Summertime operation	12
4.5 Delayed outdoor temperature adaptation	13
4.6 Automatic clock reset, summertime/wintertime	13
4.7 Public holidays and vacations	13
4.8 Thermal disinfection of drinking water storage tank	14
4.9 Return flow temperature limiting	14
4.10 Buildup of charging temperature via the return flow sensor with the heating loop switched off	15
4.11 Limiting of control deviation for the OPEN signal	15
4.12 Forced charging of the drinking water storage tank	15
4.13 Room sensor	15
4.14 Frost protection	15
4.15 Sensor failure / operation errors	16
4.16 Forced actuation of pumps	16
4.17 Master switchover for heating up of drinking water in storage tank charging system	16
4.18 Monitoring of a flow maximum temperature for heating up of drinking water	17
5. System diagrams	18
5.1 System code number 1	18
5.2 System code number 2	19
5.3 System code number 3	24
5.4 System code number 4	27

- 6. Operation 29**
- 6.1 Operating mode selection 29
- 6.2 The operating levels 30

- 7. Commissioning and adjusting the controller 35**
- 7.1 Configuration 35
- 7.1.1 System code number adjustment 35
- 7.1.2 Function block adjustment 35
- Code number setting 36
- 7.1.3 Function block lists 37
- 7.1.4 Sensor calibration 39
- 7.2 Parameter entries 40
- 7.2.1 Default value adjustment 40
- 7.2.2 Entry or modification of user data - overview 41
- Heating characteristics and temperatures 41
- Heating utilization periods 44
- Time data, heating up drinking water 47
- Time data, circulation pump 47
- Adjustment of current time, date and year 48
- Public holidays 48
- Vacations 49

- 8. Data sheets 50**



The device may only be installed and put into operation by specialist personnel familiar with installation, commissioning and operation of this product. It is assumed that the device is transported and stored correctly.

The controller is intended for use with high-voltage systems. For connection and maintenance the relevant safety regulations must be observed

1. General

The digital heating and district heating controller TROVIS 5430 is for weather-sensitive flow temperature control of heating systems, i.e. by way of a heating characteristic the flow temperature of a heating loop is regulated in such a way that the desired room temperature is adjusted, independent of the outside temperature. The return flow temperature can be limited depending on the outside temperature. Furthermore, the controller is capable of regulating heating up of drinking water.

The controller reads the respective temperature via a sensor and relays it to the central processor via corresponding input units. This modulates a control signal for the closed control loop according to the adjusted setpoint value. Depending on the configuration, the output unit converts this signal into a three-step or two-step signal. In addition, the controller controls the heating circulation pump, the heat exchanger charging pump as well as the storage loading pump.

Validity of these mounting and operating instructions

as of **firmware release 1.12**

(current firmware release appears for 2 secs. when power is switched on)

Modifications to firmware release 1.01:

Supplement to system 4

1.1 Notes for the user

The installation of the controller described in the following and its electrical connections are to be carried out by authorized personnel only.

The adjustments concerning the configuration described in chapter 7 also require a specialist knowledge of heating systems and should only be carried out by a specialist. The function descriptions and system configurations described in chapters 4 and 5 are also intended for his use.

Commissioning of the controller is normally carried out by the specialist - all adjustment data should be entered in the data sheet in chapter 8.

Temperature values and time programs are preset for the controller as default values and can be altered by the user during commissioning or later on in chapter 7.2 (parameter entries).

1.2 Technical data

Inputs	According to selected system codes, 2-phase circuit
Sensor inputs	Maximum of 7 configurable inputs for sensors (PTC or Pt 1000) (Heating/drinking water loop) 2 flow temperature sensors 1 room temperature sensor 1 outdoor temperature sensor 1 return flow temperature sensor 2 storage temperature sensors
Binary inputs	Storage thermostat
Additional inputs	Room control device for adjusting room temperature and selecting operating mode, potentiometer
Outputs	According to selected system code number
Control signal	Three-step signals: 20 to 250 V~, 0.5 A~ On-off signal: 20 to 250 V~, 0.5 A~ No DC voltage circuits!
Binary outputs	4 outputs for controlling pumps Non-isolated: 230 V~, 2 A~
Auxiliary power	230 V~ (+10 %/-15 %), 48 to 62 Hz
Power supply	Approx. 2 VA
Temperature range	0 to 50 °C (operation), -10 to 60 °C (storage)
Degree of protection	IP 40 according to IEC 529
Class of protection	I according to VDE 0106
Degree of contamination	2 according to VDE 0110
Overvoltage category	II according to VDE 0110
Humidity rating	F according to VDE 40040
Noise immunity	According to EN 50082 part 1
Noise emission	According to EN 50081 part 1
Weight	Approx. 0.6 kg

1.3 Resistance values of sensors

Resistance thermometer with PTC measuring element

Sensor resistance elements (with controller disconnected)

Sensor for outdoor temperature type 5224, for flow and return flow temperature type 5264, 5265, for storage tank temperature type 5264

°C	-20	-10	0	+10	+20	+25	+30	+40	+50	+60	+70	+80	+90	+100	+110	+120
Ω	694	757	825	896	971	1010	1050	1132	1219	1309	1402	1500	1601	1706	1815	1925
Room control device type 5244 (remote control)																
Switch at "Clock" position Terminal 1 and 2											°C	+10	+15	+20	+25	+30
											Ω	679	699	720	741	762

Resistance thermometer with Pt 1000 measuring element

Sensor for outdoor temperature type 5227, for flow and return flow temperature type 5207-21, 5207-26, 5207-27, 5277 (thermowell required) and 5267 (contact sensor with 3 m cable), for storage tank temperature type 5207-46, 5207-47 and 5207-48

Sensor for room temperature type 5257

°C	-35	-30	-25	-20	-15	-10	-5	0	5	10
Ohms	862.5	882.2	901.9	921.6	941.2	960.9	980.4	1000.0	1019.5	1039.0
°C	15	20	25	30	35	40	45	50	55	60
Ohms	1058.5	1077.9	1097.3	1116.7	1136.1	1155.4	1174.7	1194.0	1213.2	1232.4
°C	65	70	75	80	85	90	95	100	105	110
Ohms	1251.6	1270.7	1289.8	1308.9	1328.0	1347.0	1366.0	1385.0	1403.9	1422.9
°C	115	120	125	130	135	140	145	150		
Ohms	1441.7	1460.6	1479.4	1498.2	1517.0	1535.8	1554.5	1573.1		

2. Installation

2.1 Installing the controller

The controller consists of the controller housing with electronics and a housing rear panel with terminal strips. The housing rear panel can be ordered as a flat or deep version.

To connect electrically, the front screws must be loosened and the controller housing must be separated from the rear panel.

In the case of a wall mounting, the housing rear panel must be mounted on a wall using three screws. Hole spacing is given in diagram 2.

In the case of a panel mounting, the controller housing is inserted through the panel section and the enclosed screw brackets inserted on the left and right housing sides (if necessary, turn out screw completely before inserting). Then turn the screws in until the ends are firmly in contact with the rear side of the panel.

The panel section is 138^{+1} mm wide x $92^{+0.8}$ mm high.

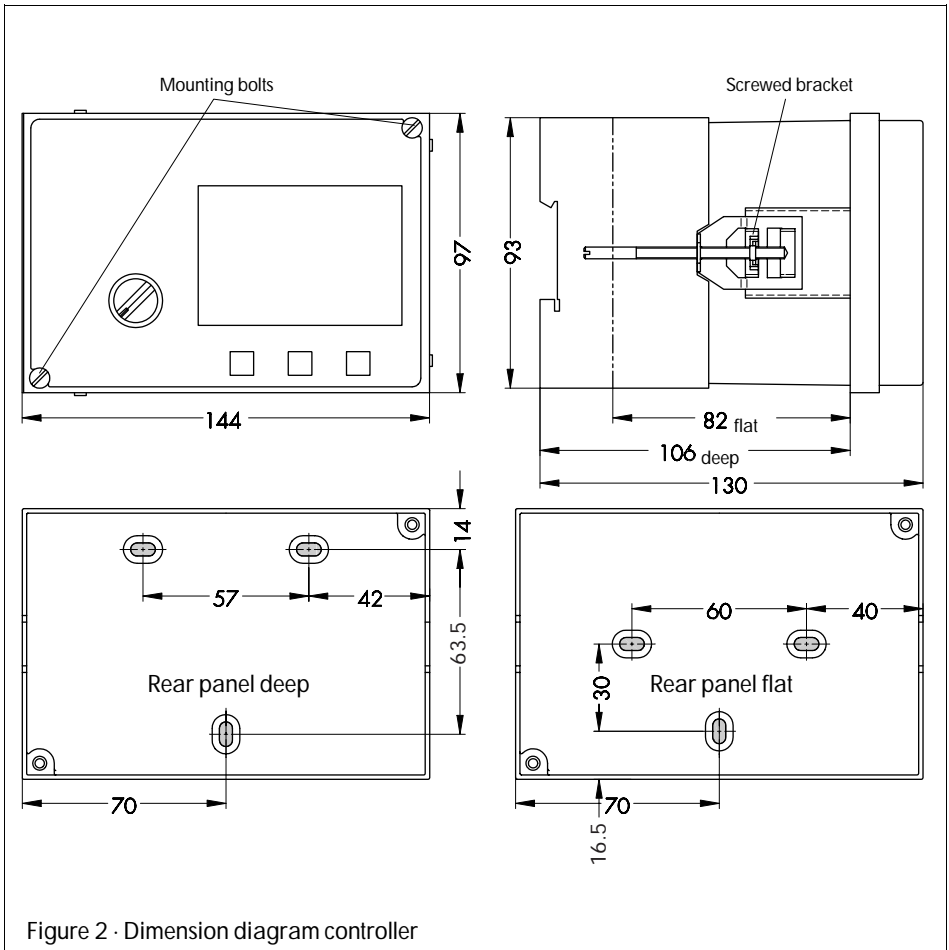

Figure 2 · Dimension diagram controller

2.2 Installing the sensors

2.2.1 Outdoor sensors

Mount outdoor sensors using two screws in a suitable location on an outside wall. Ensure that the sensor is not mounted above any warm air exits (windows, ventilation slats etc.). In the case of a detached building, if possible, mount the sensor on the wall next to the preferred living area.

2.2.2 Flow/return flow sensor

Mount the sensor as a duct temperature sensor or as a contact sensor in an easily accessible location in the vicinity of the heat exchanger.

Duct temperature sensor: Insert the duct temperature sensor in an existing thermowell and push in as far as it will go.

Contact sensor: Remove insulation in the area of the flow line where the sensor is to be mounted and clean the pipe to the bare metal. Press the sensor firmly onto the pipe and fasten securely using the accompanying tensioner.

2.2.3 Room sensor

Mount the sensor in a suitable location on the wall, approx. 150 cm high. On no account should air circulation be impeded by cupboards, curtains or similar objects.

3. Electrical connections

3.1 General notes



When laying cables and connecting the controller, VDE regulations and local electric company regulations must be observed. For this reason, the work must be carried out by a specialist.

Sensor and mains lines must be in separate cables. If contactors are in the vicinity of the controller or if inductive consumer circuits exist nearby, then these must be wired with noise suppression capacitors to avoid interference with the controller.

Radio interference suppression: The controller type 5430 with SAMSON actuators is interference-suppressed according to EN 50081 part 1 and 50082 part 1. If other actuators are used, or if other actuators with sources of radio interference are additionally used in a system, then the operator/persons installing a non-standard system must, in compliance with legal duties concerning radio interference suppression, ensure that the entire system complies with the demands in accordance with the above-listed standards.

3.2 Connecting the controller

Electrical connections must be carried out in accordance with the system code number predefined in the configuration (see chapter 7) according to the terminal diagram, figures 3 to 6. For the purpose of feeding cables, holes should be made at the locations marked on the housing rear panel and the enclosed cable glands inserted.

3.3 Connecting the sensors

Connect cables with a minimum cross-section of $2 \times 0.5 \text{ mm}^2$ at the terminal strip of the housing rear panel.

3.4 Connecting the actuator

Wire cables as humid area cables with a minimum cross-section of 1.5 mm² to the terminals of the controller output. When commissioning, it is necessary to check the direction of rotation, i.e. whether connections have been made correctly by positioning the operating switch to + and - for opening and closing the valve.

3.5 Connecting the pumps

Connect all cables with a minimum of 1.5 mm² to the controller terminals according to the corresponding circuit diagram (system 1, 2, 3 or 4).

3.6 Terminal wiring diagrams

The terminal wiring diagrams listed in the following (figures 3, 4, 5 and 6) contain all possible input and output connections for the respective system code number. If input or output connections are to remain unassigned, then this must be defined in the configuration, chapter 7.1 (level CO1 to CO SYS).

Legend :

- FG** Potentiometer (terminal 3 on room control device type 5244)
- RF** Room sensor (terminal 1 on room control device type 5244)
- AF** Outdoor sensor
- RüF** Return flow sensor
- VF** Flow sensor
- GNDF** Sensor earth
- UP** Circulation pump
- SLP** Storage loading pump
- ZP** Circulation pump
- PE** Grounding conductor
- NRK and L RK** power supply actuator

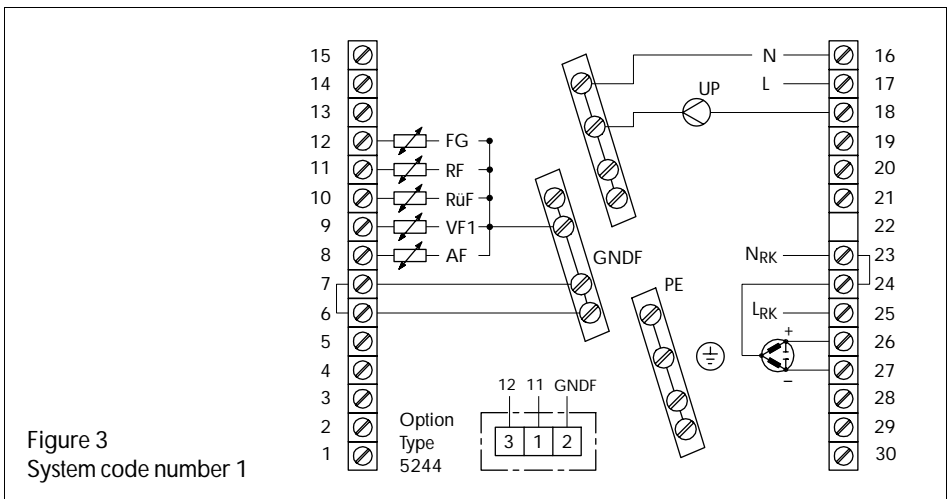

Figure 3
System code number 1

Figure 4
System code number 2

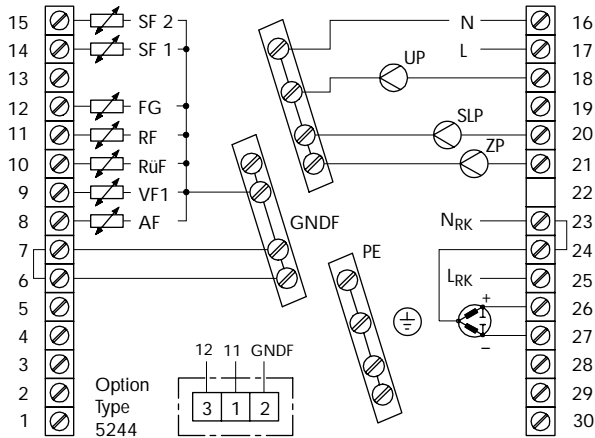

Figure 5
System code number 3

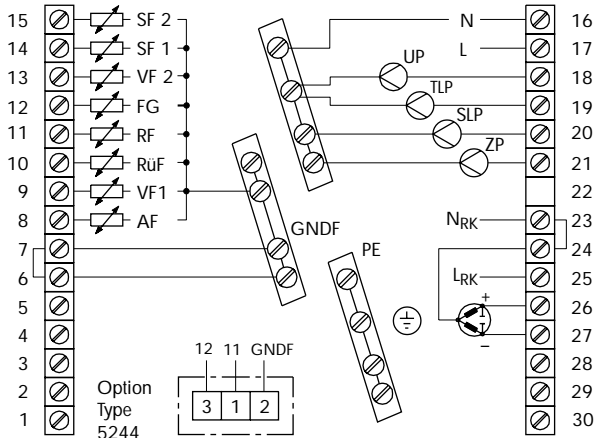
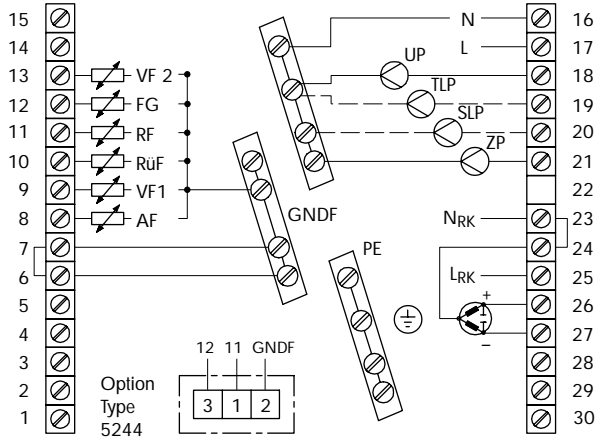

Figure 6
System code number 4



4. Description of controller functions

The following function descriptions are intended to assist comprehension of the settings required for operation.

The controller functions depend on the selected system code number, 1, 2, 3, or 4, depicted and described in chapter 5.

The tables on pages 37 and 38 can be used to clarify the configuration levels (CO) and function blocks (FB) described in the function descriptions.

4.1 Optimizing

The controller is capable of independently establishing the most appropriate times for switching the heating system on and off in periodically used buildings. For this purpose, the function block setting FB 1 = ON (linked with FB 2 = ON) is selected in configuration level CO1.

In contrast to reduced operation, the heating system is switched off at the latest at the beginning of the period of non-usage.

A so-called reference room containing the necessary room temperature sensor and representing the entire building is monitored with regard to an adjustable "sustaining temperature". If the temperature falls below this value, the heating system will operate until the sustaining temperature (with approx. 0.5 °C added for differential gap) is exceeded, using the maximum permissible flow temperature.

The controller selects switch-on time for commencing rated operation in such a way that the "room setpoint value" (temperature adjustable at controller) is just reached at the beginning of rated operation (tolerance for comfort 0.5 °C). This switch-on time may be up to 6 hours prior to the time set for commencement of rated operation (this will for instance be the case when commissioning the function "optimizing", as the controller as yet has no information regarding the characteristics of the building).

If no room sensor is connected, then heating system switch-on time can be postponed with regard to the outdoor temperature in CO1 by FB 2 = ON and Selection = 1. The maximum permissible pre-heating time is adjustable, a reference room is omitted.

With all system code numbers, drinking water requirements are not taken into consideration during the heating up period.

The controller selects heating system switch-off time in such a way that switching off the heating before the end of rated operation has no noticeable effect on the desired room temperature (comfort tolerance) towards the end of rated operation (for example sunlight can lead to an increase in room temperature especially when flash adaptation is not used, and thus to premature switching off). Switch-off time can be up to 2 hours before the time set for the end of the usage period.

If no room sensor is connected, the controller reduces the flow temperature towards the end of rated operation. If, at the beginning of reduced operation, the outdoor temperature exceeds 10 °C (default value: adjustable), then the heating system remains switched off. If the temperature falls below this limiting value during reduced operation, then the reduced return flow temperature is regulated.

If, in the course of one day, 2 or 3 rated operating times have been set, then a "reduced room setpoint value" (temperature adjustable at controller) is monitored instead of the "sustaining temperature".

4.2 Flash adaptation

It is possible to achieve a direct reaction to deviations in room temperature via the function block setting CO1 FB 3 = EIN (linked to FB 1 = ON): so-called flash adaptation counteracts deviations in room temperature within time-controlled rated operation by raising or lowering the heating characteristic by up to 10 °C (parallel adjustment of the heating characteristic).

This takes place within a time lapse of 10 minutes if the room temperature deviates from the setpoint value by more than 0.5 K. The heating characteristic adjustment takes place in steps of 1 K. With flash adaptation, the possibility of correcting the setpoint value on the remote control does not exist. Flash adaptation is terminated, i.e. the parallel adjustment is cancelled, at the end of time-controlled rated operation.

Attention! Cooling such as draughts or open windows affect control! Short-term overheating of rooms may occur after such cooling is no longer effective!

4.3 Reduced operation

In the case of reduced operation, the heating loop generally operates a flow temperature setpoint value defined by the heating characteristic, being a setpoint reduced by the value entered in "reduction of flow temperature for reduced operation".

If however, during reduced operation, the outdoor temperature exceeds the value entered as the "outdoor temperature limit for switching off during reduced operation", then the heating loop is automatically switched off by the controller; by the control valve being closed and the heating circulation pump UP being switched off after two valve running periods (the control valve running period is adjustable at the controller). If the temperature falls below the limiting value (less 0.5 °C differential gap), then heating operation starts up again immediately.

4.4 Summertime operation

During the summertime the heating loop is automatically switched off by the controller; the control valve is closed and the heating circulation pump UP is switched off after an adjustable time period. The "temperature and time-controlled summertime operation" function is linked to the setting CO1 FB 6 = ON. These are two independent functions whose effects may overlap:

The outdoor temperature level is decisive for starting up exclusively temperature-controlled summertime operation. If the temperature exceeds the "outdoor temperature limit for summertime operation" (default setting 22 °C; adjustment range: 0 to 50 °C) adjustable in the parameter level, then summertime operation starts up immediately.

If the temperature falls below the limiting value (less 1.0 °C differential gap), then heating operation starts up again immediately. This function is independent of the function block setting CO1 FB 6 = ON.

The following is decisive for starting up temperature and time-controlled summertime operation

1. The daytime mean temperature level (calculated between 0700 and 2200 hrs). If on 2 successive days the temperature exceeds the outdoor temperature limit adjustable in the configuration level, linked to the function block setting CO1 FB = ON (default setting 18 °C; adjustment range: 0 to 50 °C), and if
2. The current date is within the effective time period linked to the function block setting CO1 FB 6 = ON, adjustable in the configuration level (default setting 01/06 to 30/09), then sum-

meritime operation commences on the second day. If the daytime mean temperature level falls below the outdoor temperature limit on two successive days, then summertime operation is terminated on the following day.

4.5 Delayed outdoor temperature adaptation

A calculated outdoor temperature is used to determine the flow temperature. This delayed adaptation occurs

- a) only if the outdoor temperature falls, or
- b) independent of outdoor temperature variations.

If the outdoor temperature varies within a very short period, e.g. by 12 °C, then the "calculated outdoor temperature" is adapted to the outdoor temperature in small steps over a period of 4 hours with a delayed setting of 3 °C/h.

It is possible to avoid unnecessary heating central system overloads, overheating of buildings, e.g. warm winds, (case a), or temporarily insufficient heating due to excessive sunlight to the outdoor sensors (case b) using the setting CO1 FB = ON.

The selection immediately following the function block setting CO1 FB 5 = ON: Selection 1 means delaying only in the case of falling outdoor temperatures.

Selection 2 means delaying when the outdoor temperature rises and falls.

Subsequently the delay setting is entered (default setting 3 °C/h; adjustment range: 1 to 6 °C/h). In the operating level, an active delayed adaptation to the outdoor temperature is indicated by a flashing display. As long as the  key is held down, the "calculated outdoor temperature" is displayed.

4.6 Automatic clock reset, summertime/wintertime

The clock time reset function is linked to the function block setting CO SYS FB 3 = ON. The clocks are automatically reset on the last Sunday in March at 0200 hrs and on the last Sunday in October at 0300 hrs.

4.7 Public holidays and vacations

The controller has the capability of defining 20 public holidays and 10 vacation periods (parameter level PASYS). The following public holidays are preset as standard: 01/01, 01/05, 25/12 and 26/12 (deletion is of course possible).

On public holidays the heating loop relies on time data as for Sundays (heating time data); during vacation periods reduced operation or standby operation occurs. Heating up of drinking water is not affected by public holiday and vacation settings when the controller is on a standard setting. Only if the function block setting is CO2 FB 7 = ON, will heating up of drinking water function as for Sunday settings (time data, drinking water).

Subsequently, no heating up of drinking water occurs during a vacation period (frost protection monitoring as of +5 °C).

4.8 Thermal disinfection of drinking water storage tank

This function cannot be used in conjunction with a storage tank thermostat.

On all systems with heating up of drinking water the function block setting CO2 FB 5 = ON causes the storage tank to be charged at 75 °C every week on a selected day at 0000 hrs.

The heat exchanger charging pump TLP is immediately switched on, regardless of the flow temperature values which have been measured. If the charging temperature attains the current storage tank temperature at the storage tank sensor SF1 and if the master switchover is active CO2 FB 3 = ON, then the controller switches over to the flow sensor in the storage tank charging loop, the storage tank charging pump SLP switches on and regulates a fixed value of 75 °C. If CO2 FB 3 is OFF, or system code number 2 is active, then the master switchover remains inactive.

The circulation pump ZP is now switched off if in the configuration CO2 FB 4 OFF is set, i.e. ZP does not run according to time program during storage tank charging.

If a temperature of 70 °C is attained at the storage tank sensor SF 1 or at the storage tank sensor SF 2 (if two storage tank sensors are used), however at the latest at 0400 hrs, thermal disinfection is terminated (pump lag may occur).

If at the end of thermal disinfection, for instance due to reasons to do with hydraulics, the increased storage tank setpoint value is not attained, then the symbol "operation error" will flash in the display.

This warning is acknowledged manually by calling up the "Error" level and confirming the error message (error 02) with the enter key. This warning resets itself automatically when the increased storage tank setpoint value is attained during a later disinfection phase.

4.9 Return flow temperature limiting

In order to be able to operate a district heating system economically, it is necessary to extract as much heat as possible from the heat conductor (water) coming from the heating supplier. The temperature difference between network flow and return flow is an energy efficiency indicator. A large difference in temperature indicates a high efficiency level, a small difference in temperature indicates a low efficiency level. With preset network flow temperatures a return flow sensor is sufficient for evaluating the difference in temperature.

The function is as follows: Limiting of the return flow temperature can depend either on the outdoor temperature (floating) or be fixed. If the return flow temperature measured at the return flow sensor RfF exceeds the value calculated as a result of the preset return flow characteristic or the fixed limiting value by, say, 2 °C, then the respective calculated setpoint value or the fixed setpoint value setting (return flow temperature heating, charging temperature) is reduced by 2 °C. In this way the primary flow will be reduced and the return flow temperature will drop. In the case of limiting, both the measured value display "return flow temperature" as well as the setpoint value display (return flow temperature heating, charging temperature) will blink. The function is already activated by the function block setting CO SYS FB 1 = ON.

In the case of system code numbers 2 and 3 (heated up drinking water from the secondary loop), it is standard during heating up of drinking water to switch over from the heating side return flow temperature limiting value (usually calculated from the return flow temperature limiting characteristic) to the limiting value "return flow limiting temperature during heating up of drinking water" (temperature adjustable at controller). In this way it is safe to run low return flow limiting temperatures during the seasonal interim between summer and winter (or vice-versa) without endangering proper charging of the storage tank.

4.10 Buildup of charging temperature via the return flow sensor with the heating loop switched off

This function is only active with system code number 2. If, during the usage period, the heating loop is switched off, then in the case of storage tank charging the storage loading pump is only switched on when the temperature at the return flow sensor attains the temperature level measured at storage tank sensor 1. This prevents cold water entering the storage tank when loading begins. During this time, return flow temperature limiting is adjusted to the flow temperature setpoint value. The function block setting CO2 FB 8 = OFF allows this function to be deselected.

4.11 Limiting of control deviation for the OPEN signal

When using the controller to regulate steam pressure it is advisable to activate limiting of control deviation for the OPEN signal. This function can be used to dampen the reaction of the controller to setpoint deviations which result in opening the primary control valve, thus allowing in particular the starting up process of such systems to be less problematic. The reaction of the controller to setpoint value deviations resulting in closing of the control valve is not influenced. This function is activated via CO SYS FB 6 = ON for all system code numbers.

The entry for limiting the standard deviation to between 2 and 10 °C (standard setting 2 °C) immediately follows the function block setting CO SYS FB 6.

4.12 Forced charging of the drinking water storage tank

This function is implemented as standard on all system code numbers with heating up of drinking water, can however not be used in conjunction with a storage tank thermostat (CO2 FB 1 and FB 2 = OFF).

In order to guarantee sufficient charging of the drinking water storage tank at the beginning of the rated operational time (or at the beginning of the heating up phase during optimizing operation), forced charging commences one hour prior to the time set for the start of the heating loop usage period (or one hour prior to the calculated beginning of heating up in optimizing operation), insofar as the utilization period of the drinking water loop does not terminate at the beginning of the utilization period of the heating loop.

Charging of the storage tank is terminated, as usual, by the differential gap for storage tank sensor SF 1 being exceeded, or by the temperature "drinking water requirement OFF" at storage tank sensor SF2 being exceeded.

4.13 Room sensor

If the room sensor is activated by CO1 FB 1, but neither optimizing nor flash adaptation is activated, the room temperature setpoint value is displayed but not used for controlling purposes.

4.14 Frost protection



As a rule, the heating circulation pump UP is switched on when the outdoor temperature falls below 0 °C. The circulation pump ZP is also switched on as long as no storage tank charging occurs.

If the flow temperature falls below 5 °C, then a setpoint value of 20 °C is regulated for 5 minutes. If the drinking water storage tank temperature falls below 5 °C outdoor rated operating times of the drinking water loop, then storage tank charging commences (exception: systems with a storage tank thermostat). Storage tank charging terminates when the warm water temperature exceeds 10 °C.

Frost protection is not active in manual operation.

4.15 Sensor failure/operation errors

Interruptions or a short circuit of the sensor lines as well as other operational errors are displayed in the operating level by an "ERROR" message. If this level is opened, then the controller indicates the defective sensors by corresponding combinations of symbols. Operational errors are displayed using the following number codes:

- Err 1: New reading in of cold start values. Acknowledgment in the error level via the  key.
- Err 2: Increased storage tank setpoint value during thermal disinfection not attained.
Acknowledgment in the error level via the  key.
- Err 3: Device not calibrated. No acknowledgment possible.
- Err 4: The operating switch was in a non-valid position for more than 10 seconds, e.g. between two switch positions, or is defective.

Outdoor temperature sensor AF: in the case of a defective outdoor sensor, a flow temperature setpoint value of 50 °C or the value set under "max. flow temperature" is run (if the temperature value "max. flow temperature" is less than 50 °C).

Flow temperature sensor VF 1: in the case of flow sensor failure the controller continues to function in the last valve position.

Flow temperature sensor drinking water storage tank VF 2: A failure of this sensor only leads to regulation of the flow temperature setpoint value for the drinking water exchanger on the VF 1. The warning display will blink all the same.

Return flow temperature sensor RüF: In the case of a defective return flow sensor the controller continues to function without return flow temperature limiting.

Room temperature sensor RF: In the case of room sensor failure the controller functions in accordance with the settings for operation with no room sensor, e.g. is switched over from optimizing to reduced operation. In the case of adapted operation, this is cancelled; the most recently determined heating characteristic remains unaltered.

Storage tank temperature sensor SF 1 and SF 2: if one of the two sensors fails, storage tank charging no longer occurs.

4.16 Forced actuation of pumps

The circulation pump is activated by program once a day between 1200 and 1201 hrs. Forced running of the storage loading pump or of the heat exchanger charging pump commences between 1201 and 1202 hrs.

4.17 Master switchover for heating up of drinking water in storage tank charging system

If under system code number 3 an additional flow sensor (VF 2) downstream of the heat exchanger for heating up of drinking water is desired in addition to the standard flow sensor (VF 1), then CO2 FB 3 must be set to ON on the controller. This has the effect of mastering of the closed control loop being switched over from VF1 to VF2 one minute after the storage loading pump is being switched on.

4.18 Monitoring of a flow maximum temperature for heating up of drinking water

If heating up of drinking water with master switchover is selected (possible only on system code number 3), the controller monitors the flow temperature at the flow sensor for the heat exchanger during storage charging.

If this, for instance, exceeds an adjustable maximum value due to increased warm water usage on the drinking water side, the controller uses this value until this increase in requirements is no longer valid.

Attention! Under certain circumstances (e.g. scale deposits in the heat exchanger) it is possible that this maximum value setting may not be terminated.

To prevent unintentional limiting, the default value is set to 120 °C by the manufacturer and must be modified according to requirements.

5. System diagrams

Preliminary remarks:

The system diagrams depicted contain only the system components relevant to the control, not however safety relevant system components.

If a temperature regulator (TR) or a safety temperature monitor (STW) or additionally a pressure limiter (DB) is required, a control device with a safety function according to DIN 32730 must be used.

If a TR/STW combination according to DIN 4747 part 1 is required, a DB (if necessary) according to DIN 4751 should be selected.

A TR/STB combination according to DIN 4753 should, if necessary, be selected for heating up of drinking water.

Heating control (all systems)

The circulation pump UP runs in rated operation. The flow temperature setpoint value is calculated from the heating characteristic (gradient or 4-point characteristic CO1 FB4 = ON).

The circulation pump UP runs in reduced operation. The flow temperature setpoint value is calculated from the heating characteristic (gradient or 4-point characteristic) less the value entered under "reduction of flow temperature for reduced operation" (in the case of a 4-point heating characteristic, a reduction value for characteristic points 2 and 3 each should be entered).

5.1 System code number 1

(This system does not process heating up of drinking water.)

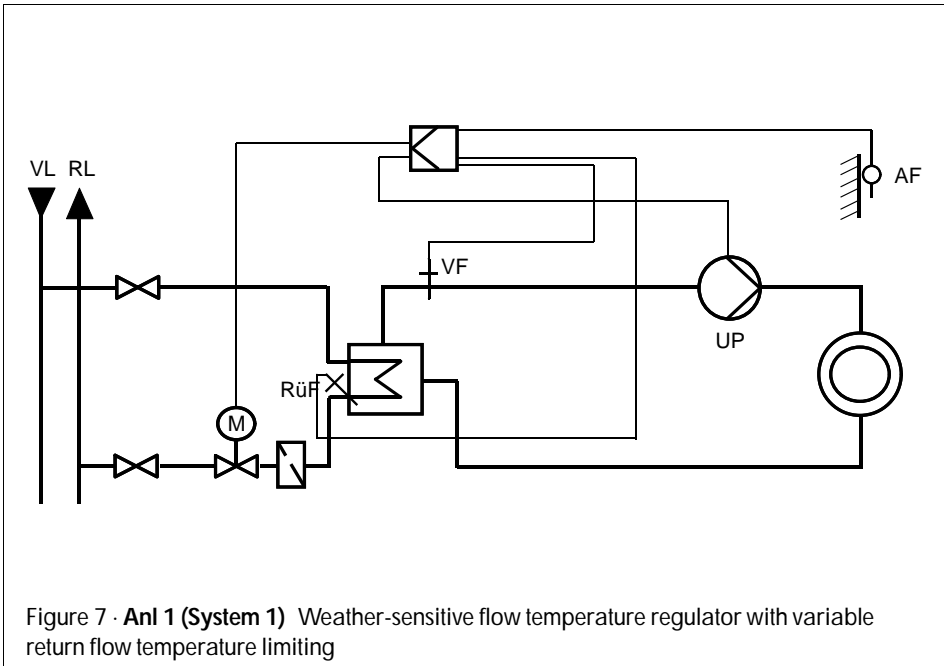

Figure 7 · Anl 1 (System 1) Weather-sensitive flow temperature regulator with variable return flow temperature limiting

5.2 System code number 2

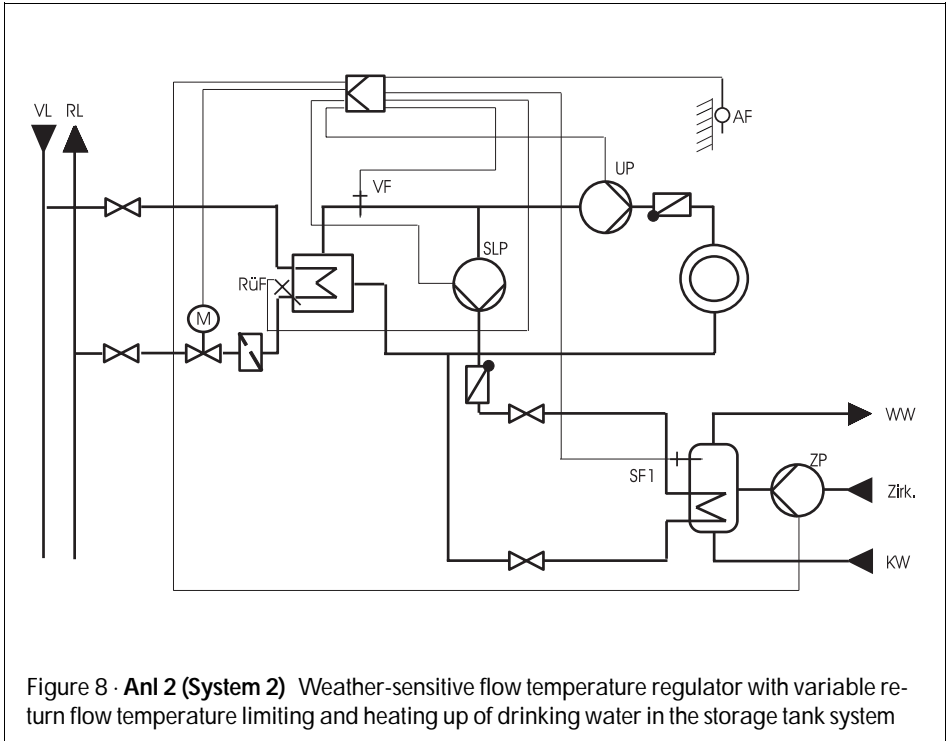

Figure 8 · Anl 2 (System 2) Weather-sensitive flow temperature regulator with variable return flow temperature limiting and heating up of drinking water in the storage tank system

Processing heating up of drinking water

Four different cases are distinguished:

A) The temperature at the flow sensor is higher than the charging temperature setpoint value

If the temperature in the storage tank falls below the value for drinking water requirement ON at sensor SF1 or if the temperature falls below the value set at the storage tank thermostat, commencement of storage tank charging initially only leads to a reduction of the excessive flow temperature via the heating loop.

At 5K above the charging setpoint value (measured at flow sensor VF), at the latest after 3 minutes, the storage loading pump (described as SLP in the following) starts up. At the same time the circulation pump (in the following described as UP) is switched off; the circulation pump (in the following described as ZP) runs according to the function block setting.

If the requirement is terminated by exceeding the adjustable differential gap at sensor SF1 or the preset differential gap at the storage tank thermostat, the controller initially runs at a fixed definable value at sensor VF. When this is attained, at the latest after two running periods of the control valve, the UP is switched on and the SLP is switched off. The ZP runs according to a time program.

B) The temperature at the flow sensor is less than the charging temperature setpoint value, but higher than 40 °C

If the temperature in the storage tank falls below the value for drinking water requirement ON at sensor SF1 or if the temperature falls below the value set at the storage tank thermostat, commencement of storage tank charging initially only leads to a buildup of the charging temperature via the heating loop.

At 5K below the charging setpoint value (measured at flow sensor VF), the SLP starts up. At the same time the UP is switched off; the ZP runs according to the function block setting.

If the requirement is terminated by exceeding the adjustable differential gap at sensor SF1 or the preset differential gap at the storage tank thermostat, the controller initially runs at a fixed definable value at sensor VF. When this is attained, at the latest after two running periods of the control valve, the UP is switched on and the SLP is switched off. The ZP runs according to a time program.

C) The temperature at the flow sensor is less than 40 °C

If the temperature in the storage tank falls below the value for drinking water requirement ON at sensor SF1 or if the temperature falls below the value set at the storage tank thermostat, commencement of storage tank charging leads to an immediate buildup of the charging temperature via the storage tank, i.e. the UP is switched off and the SLP is switched on. The ZP runs according to the function block setting.

If the requirement is terminated by exceeding the adjustable differential gap at sensor SF1 or the preset differential gap at the storage tank thermostat, the controller operates again according to the heating characteristic; while the control valve is closing, the flow temperature is monitored at sensor VF. If this is reduced down to a fixed definable value, at the latest however after two running periods of the control valve, the UP is switched on and the SLP is switched off. The ZP runs according to a time program.

D) Summertime operation or switched off operation

If the temperature in the storage tank falls below the value for drinking water requirement ON at sensor SF1 or if the temperature falls below the value set at the storage tank thermostat, commencement of storage tank charging leads to an immediate buildup of the charging temperature via the storage tank, i.e. the SLP is switched on. The ZP runs according to the function block setting.

If CO2 FB 8 = ON, the SLP is only switched on when the temperature at sensor RÜF is higher than the temperature at sensor SF1.

When the requirement is terminated, the control valve is closed. While the control valve is closing, the flow temperature is monitored at sensor VF. If this is reduced down to a fixed definable value, at the latest however after two running periods of the control valve, the UP is switched on and the SLP is switched off. The ZP runs according to a time program.

System code number 2 with CO2 FB 6 = ON selection: 1 (parallel pump operation)

Processing heating up of drinking water in the storage tank system with parallel pump operation

A) The temperature at the flow sensor is higher than the charging temperature setpoint value

If the temperature in the storage tank falls below the value for drinking water requirement ON at sensor SF1 or if the temperature falls below the value set at the storage tank thermostat, commencement of storage tank charging initially only leads to a reduction of the excessive flow temperature via the heating loop.

At 5K above the charging setpoint value (measured at flow sensor VF), at the latest after 3 minutes, the SLP starts up. The ZP runs according to the function block setting. If a value of more than 2 K below the charging temperature is registered for a time period of 3 minutes, the UP is switched off for 10 minutes.

If the requirement is terminated by exceeding the adjustable differential gap at sensor SF1 or the preset differential gap at the storage tank thermostat, the controller initially runs at a fixed definable value at sensor VF. When this is attained, at the latest after two running periods of the control valve, the SLP is switched off and the UP continues.

The ZP runs according to a time program.

B) The temperature at the flow sensor is less than the charging temperature setpoint value, but higher than 40 °C

If the temperature in the storage tank falls below the value for drinking water requirement ON at sensor SF1 or if the temperature falls below the value set at the storage tank thermostat, commencement of storage tank charging initially only leads to a buildup of the charging temperature via the heating loop.

At 5K below the charging setpoint value (measured at flow sensor VF), the storage loading pump SLP starts up. The ZP runs according to the function block setting. If a value of more than 2 K below the charging temperature is registered for a time period of 3 minutes, the UP is switched off for 10 minutes.

If the requirement is terminated by exceeding the adjustable differential gap at sensor SF1 or the preset differential gap at the storage tank thermostat, the controller initially runs at a fixed definable value at sensor VF. When this is attained, at the latest after two running periods of the control valve, the SLP is switched off and the UP continues to run. The ZP runs according to a time program.

C) The temperature at the flow sensor is less than 40 °C

If the temperature in the storage tank falls below the value for drinking water requirement ON at sensor SF1 or if the temperature falls below the value set at the storage tank thermostat, commencement of storage tank charging leads to an immediate buildup of the charging temperature via the storage tank, i.e. the UP is switched off and the SLP is switched on. The ZP runs according to the function block setting.

If the requirement is terminated by exceeding the adjustable differential gap at sensor SF1 or the preset differential gap at the storage tank thermostat, the controller operates again according to the heating characteristic; while the control valve is closing the flow temperature is monitored at sensor VF. If this is reduced down to a fixed definable value, at the latest however after two running periods of the control valve, the UP is switched on and the SLP is switched off. The ZP runs according to a time program.

D) Summertime operation or switched off operation

A drinking water requirement leads to an immediate buildup of the charging temperature via the storage tank, i.e. the SLP is switched on. The ZP runs according to the function block setting.

If CO2 FB 8 = ON, then the SLP is only switched on when the temperature at sensor RUF is higher than the temperature at sensor SF1.

When the requirement is terminated the control valve is closed. While the control valve is closing, the flow temperature is monitored at sensor VF. If this is reduced down to a fixed definable value, at the latest however after two running periods of the control valve, the UP is switched on and the SLP is switched off. The ZP runs according to a time program.

System code number 2 with changeover valve CO2 FB 6 = ON selection: 2 (changeover valve)

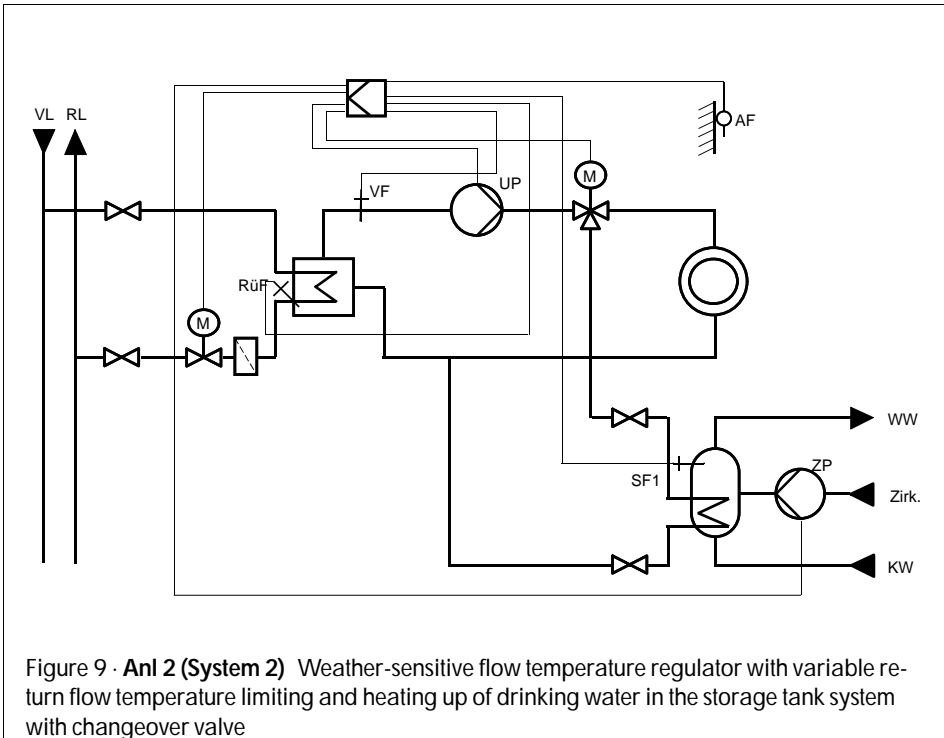

Figure 9 · Anl 2 (System 2) Weather-sensitive flow temperature regulator with variable return flow temperature limiting and heating up of drinking water in the storage tank system with changeover valve

Processing heating up of drinking water in the storage tank system with changeover valve

A) The temperature at the flow sensor is higher than the charging temperature setpoint value

If the temperature in the storage tank falls below the value for drinking water requirement ON at sensor SF1 or if the temperature falls below the value set at the storage tank thermostat, commencement of storage tank charging initially only leads to a reduction of the excessive flow temperature via the heating loop.

At 5K above the charging setpoint value (measured at flow sensor VF), at the latest after three minutes, the changeover valve begins to conduct the heating medium in the direction of the storage tank.

The UP must continue to run for storage tank charging! The ZP runs according to the function block setting.

If the changeover valve is a motor valve, a limit switch at the drive can be used to conduct part of the heating medium to the heating loop during storage tank charging.

If the requirement is terminated by exceeding the adjustable differential gap at sensor SF1 or the preset differential gap at the storage tank thermostat, the controller initially continues to operate using a fixed definable value at sensor VF. If this is attained, at the latest however after two running periods of the control valve, the control valve begins to conduct the heating medium in the direction of the heating loop again. The ZP runs according to a time program.

B) The temperature at the flow sensor is less than the charging temperature setpoint value, but higher than 40 °C

If the temperature in the storage tank falls below the value for drinking water requirement ON at sensor SF1 or if the temperature falls below the value set at the storage tank thermostat, commencement of storage tank charging initially only leads to a buildup of the charging temperature via the heating loop. At 5K below the charging setpoint value the changeover valve begins to conduct the heating medium in the direction of the storage tank. The ZP runs according to the function block setting.

If the requirement is terminated by exceeding the adjustable differential gap at sensor SF1 or the preset differential gap at the storage tank thermostat, the controller initially runs at a fixed definable value at sensor VF. When this is attained, at the latest after two running periods of the control valve, the changeover valve begins to conduct the heating medium in the direction of the heating loop again. The ZP runs according to a time program.

C) The temperature at the flow sensor is less than 40 °C

A drinking water requirement leads to an immediate buildup of the charging temperature via the storage tank, i.e. the changeover valve begins to conduct the heating medium in the direction of the storage tank. The ZP runs according to the function block setting.

If the requirement is terminated by exceeding the adjustable differential gap at sensor SF1 or the preset differential gap at the storage tank thermostat, the controller operates again according to the heating characteristic; while the control valve is closing, the flow temperature is monitored at sensor VF. If this is reduced down to a fixed definable value, at the latest however after two running periods of the control valve, the changeover valve begins to conduct the heating medium in the direction of the heating loop again. The ZP runs according to a time program.

D) Summertime operation or switched off operation

A drinking water requirement leads to an immediate buildup of the charging temperature via the storage tank, i.e. the UP is switched on and the changeover valve begins to conduct the heating medium in the direction of the storage tank. The ZP runs according to the function block setting. When the requirement is terminated the control valve is closed. While the control valve is closing, the flow temperature is monitored at sensor VF.

If this is reduced down to a fixed definable value, at the latest however after two running periods of the control valve, the changeover valve switches again and the UP is switched off. The ZP runs according to a time program.

5.3 System code number 3

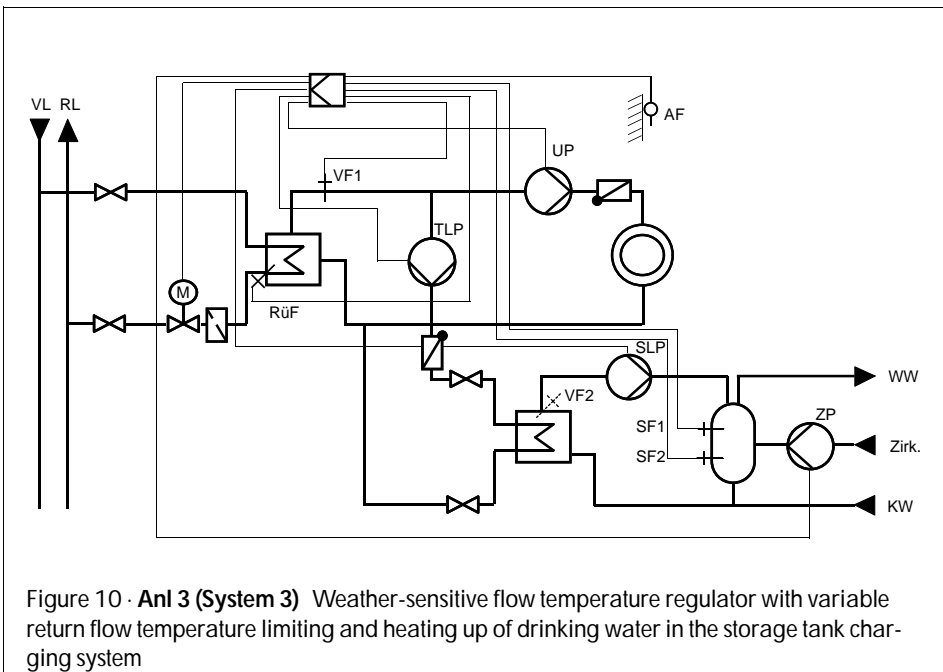

Figure 10 · Anl 3 (System 3) Weather-sensitive flow temperature regulator with variable return flow temperature limiting and heating up of drinking water in the storage tank charging system

Processing heating up of drinking water

A) The temperature at the flow sensor is higher than the charging temperature setpoint value

If the temperature in the storage tank falls below the value for drinking water requirement OFF at sensor SF2 or if the temperature falls below the value set at the storage tank thermostat, commencement of storage tank charging initially only leads to a reduction of the excessive flow temperature via the heating loop.

At 5 K above the charging setpoint value (measured at flow sensor VF), at the latest after 3 minutes, the heat exchanger pump TLP and storage loading pump SLP start up. At the same time the UP is switched off; the ZP runs according to the function block setting.

If the requirement is terminated by exceeding the adjustable differential gap at sensor SF2 or the preset differential gap at the storage tank thermostat, the controller initially runs at a fixed definable value at sensor VF1. When this is attained, at the latest after two running periods of the control valve, the UP is switched on and the TLP is switched off. If CO2 FB 3 = ON, the SLP is switched off if the temperature at sensor VF2 falls below an adjustable value, in all cases however after two running periods of the control valve. The ZP runs according to a time program.

B) The temperature at the flow sensor is less than the charging temperature setpoint value

If the temperature in the storage tank falls below the value for warm water requirement OFF at sensor SF2 or if the temperature falls below the value set at the storage tank thermostat, commencement of storage tank charging initially only leads to a buildup of the charging temperature via the heat exchanger loop, i.e. the UP is switched off, the ZP runs according to the function block setting. At the same time the TLP is switched on. If the temperature at flow sensor VF 1 at-

tains the temperature at storage tank sensor ON SF1, the SLP is switched on. If the requirement is terminated by exceeding the adjustable differential gap at sensor SF1 or the preset differential gap at the storage tank thermostat, the controller operates again according to the heating characteristic; the UP is switched on. The TLP is switched off if the temperature at sensor VF1 falls below an adjustable value. If CO2 FB 3 = ON, the SLP is switched off if the temperature at sensor VF2 falls below an adjustable value, in all cases however (with CO2 FB 3 = OFF also) after two running periods of the control valve. The ZP runs according to a time program.

C) omitted

D) Summertime operation or switched off operation

If in the storage tank the temperature falls below the value for warm water requirement OFF at sensor SF2 or if the temperature falls below the value set at the storage tank thermostat, commencement of storage tank charging initially only leads to a buildup of the charging temperature via the heat exchanger loop, i.e. the TLP is switched on, the ZP runs according to the function block setting. If the temperature at flow sensor VF 1 attains the temperature at storage tank sensor ON SF1, the SLP is switched on.

If the requirement is terminated by exceeding the adjustable differential gap at sensor SF1 or the preset differential gap at the storage tank thermostat, the control valve closes and the flow temperature is monitored at sensor VF1. The TLP is switched off if the temperature at sensor VF1 falls below a definable fixed value. If CO2 FB 3 = ON, the SLP is switched off if the temperature at sensor VF2 falls below a definable fixed value, in all cases however (with CO2 FB 3 = OFF also) after two running periods of the control valve. The ZP runs according to a time program.

System code number 3 with CO2 FB 6 = ON (parallel pump operation)

A) The temperature at the flow sensor is higher than the charging temperature setpoint value

If the temperature in the storage tank falls below the value for drinking water requirement OFF at sensor SF2 or if the temperature falls below the value set at the storage tank thermostat, commencement of storage tank charging initially only leads to a reduction of the excessive flow temperature via the heating loop.

At 5 K above the charging setpoint value (measured at flow sensor VF1), at the latest after 3 minutes, TLP and SLP start up. The UP continues to run, the ZP runs according to the function block setting. If a value of more than 2 K below the charging temperature is registered for a time period of 3 minutes, then the UP is switched off for 10 minutes.

If the requirement is terminated by exceeding the adjustable differential gap at sensor SF2 or the preset differential gap at the storage tank thermostat, the controller initially runs at a fixed definable value at sensor VF1. When this is attained, at the latest after two running periods of the control valve, the TLP is switched off. Subsequently the controller operates according to the heating characteristic again. The SLP continues to run for a period of two control valve running periods. If CO2 FB 3 = ON, the SLP is switched off if the temperature at sensor VF2 falls below a definable fixed value, in all cases however (with CO2 FB 3 = OFF also) after two running periods of the control valve. The ZP runs according to a time program.

B) The temperature at the flow sensor is less than the charging temperature setpoint value, but higher than 40 °C

If in the storage tank the temperature falls below the value for warm water requirement ON at sensor SF1 or if the temperature falls below the value set at the storage tank thermostat, commencement of storage tank charging initially only leads to a buildup of the charging temperature via the heat exchanger loop parallel to operation of the heating loop; the TLP is switched on. If the temperature at flow sensor VF 1 attains the temperature at storage tank sensor ON SF1, the SLP is switched on. The ZP runs according to the function block setting. If a value of more than 2 K below the charging temperature is registered for a time period of 3 minutes, the UP is switched off for 10 minutes.

If the requirement is terminated by exceeding the adjustable differential gap at sensor SF1 or the preset differential gap at the storage tank thermostat, the controller operates again according to the heating characteristic; the flow temperature is monitored at sensor VF1. If this is reduced to a definable fixed value, the TLP is switched off. The SLP is only switched off after two running periods of the control valve.

If CO2 FB 3 = ON, the SLP is switched off if the temperature at sensor VF2 falls below a definable fixed value, in all cases however (with CO2 FB 3 = OFF also) after two running periods of the control valve. The ZP runs according to a time program.

C) The temperature at the flow sensor is less than 40 °C

A drinking water requirement leads to an immediate buildup of the charging temperature via the heat exchanger loop, i.e. the TLP is switched on. The ZP runs according to the function block setting. If the temperature at flow sensor VF1 attains the temperature at flow sensor ON SF1, the SLP is switched on and the UP is switched off.

If the requirement is terminated by exceeding the adjustable differential gap at sensor SF1 or the preset differential gap at the storage tank thermostat, the control valve closes and the flow temperature is monitored at sensor VF1. If this is reduced to a definable fixed value, the TLP is switched off. The UP is switched on. The SLP is only switched off after two running periods of the control valve.

If CO2 FB 3 = ON, the SLP is switched off if the temperature at sensor VF2 falls below a definable fixed value, in all cases however (with CO2 FB 3 = OFF also) after two running periods of the control valve. The ZP runs according to a time program.

D) Summertime operation or switched off operation

A drinking water requirement leads to an immediate buildup of the charging temperature via the heat exchanger loop, i.e. the TLP is switched on. The ZP runs according to the function block setting. If the temperature at flow sensor VF1 attains the temperature at flow sensor ON SF1, the SLP is switched on and the UP remains switched off.

If the requirement is terminated by exceeding the adjustable differential gap at sensor SF1 or the preset differential gap at the storage tank thermostat, the control valve closes and the flow temperature is monitored at sensor VF1. If this is reduced to a definable fixed value, the TLP is switched off. The SLP is only switched off after two running periods of the control valve.

If CO2 FB 3 = ON, the SLP is switched off if the temperature at sensor VF2 falls below a definable fixed value, in all cases however (with CO2 FB 3 = OFF also) after two running periods of the control valve. The ZP runs according to a time program.

For heating up of drinking water the following general rule applies: Charging is interrupted after 20 minutes for 10 minutes in order to continue heating operation.

5.4 System code number 4

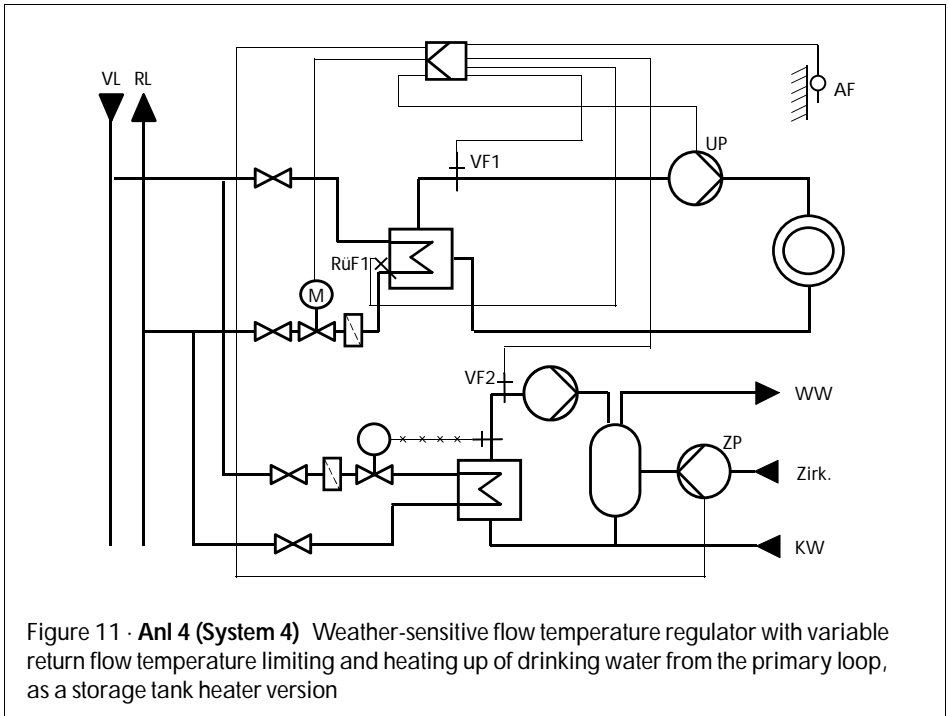

Figure 11 · Anl 4 (System 4) Weather-sensitive flow temperature regulator with variable return flow temperature limiting and heating up of drinking water from the primary loop, as a storage tank heater version

Heating up of drinking water with reverse control (with CO2 FB 9 = ON)

In case of house stations using a temperature regulator without auxiliary power for heating up of drinking water built into the primary side, priority can be guaranteed for this regulator via reverse control.

Reverse control is only activated when heating up of drinking water is released by means of an attendant time program and the heating loop is not at the same time switched off (e.g. during summer operation).

If the temperature measured at flow sensor VF2 falls below the adjusted setpoint value for heating up of drinking water by more than 5 K for the cycle time entered under CO2 FB 9, the setpoint value for the heating loop is reduced by 5 K to enable heating up of drinking water. This reduction may attain the value in the parameter "minimum flow temperature".

If at the commencement of reverse control the current flow temperature of the heating loop is below its setpoint value, the heating flow temperature is reduced by 5 K to accelerate heating up of drinking water.

If the drinking water temperature measured at flow sensor VF2 is within 5 K below its setpoint value, the current setpoint value of the heating loop is maintained.

If the drinking water temperature at flow sensor VF2 exceeds the setpoint value, the setpoint value of the heating loop is incremented in steps of 5 K. As a general rule, reverse control terminates when the time program for heating up of drinking water has ended.

6. Operation

6.1 Operating mode selection

The operating mode can be selected with the operating switch.

The switch is accessible when the door at the front is opened.

The default setting is time-controlled operation, the switch positions with their respectively assigned symbols are as follows:

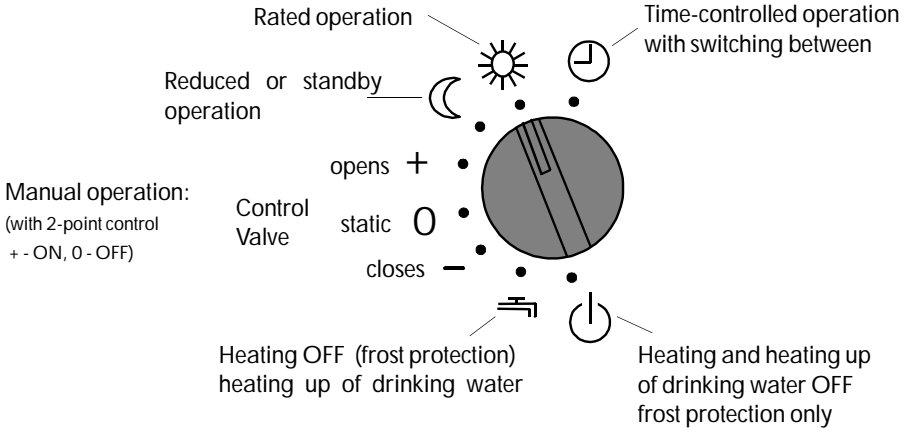

6.1.1 Heating remote control

(On room device type 5244 only)

It is possible to change the operating mode or correct the setpoint value within the heating loop directly from the room using the remote control.

Switch positions on the remote control only take effect if the operating switch on the controller is at the clock symbol position.

- 🕒 Time-controlled operation
- ☀️ Rated operation
- 🌙 Reduced or standby operation
- + Raise room temperature
- Lower room temperature
- 0 No correction

Setpoint value corrections during rated operation times are only effective if no adaptation operation is set (chapter 4.1 and 4.2).

6.2 The operating levels

Controller adjustment and operation is via three keys. They enable you to switch from one operating level to another to request data on the display or to enter data.



Entry keys:

For adjusting and requesting displays and values in ascending and descending order



Accept key:

Operating level: for displaying setpoint values entered

Parameter level: for selecting and accepting values and data which have been entered

Configuration level: for selecting and accepting the system code number and the function blocks

After connecting the power supply during commissioning, the controller enters the operating level. In order to set up the controller, it is necessary to switch from the operating level first to the configuration level and then to the parameter levels.

Figure 12 shows an operating level overview, displaying the menu fields. Menu fields may be randomly selected at every level using the enter keys (up or down).

Pressing the accept key accesses the respective sub-menu. The enter keys select the desired configuration or parameter item for a request or in order to make an entry.

Exiting the sub-menu is by switching to the display **End** and pressing the accept key. This accesses the next menu field.

Menu fields COPA or INFO must be selected to switch from **INFO** level to **COPA** level or vice-versa.

Pressing the accept key accesses the desired level and from there the required menu field is reached by way of the enter keys.



Simultaneous pressing of both enter keys allows you to exit a sub-menu at any time.

Except when a symbol blinks while entering, it is not possible to exit.

6.2.1 Configuration levels (CO1 – CO SYS)

These levels are for adapting the controller and its possible functions to the system requirements, see chapter 7.1.

6.2.2 Parameter levels (PA1 – PA SYS)

User data, such as time, date, characteristic, setpoint values, usage times etc., see chapter 7.2, are entered here.

6.2.3 Operating level (INFO1 – INFO 2)

Here the controller is normally in rated operation with time-controlled switching to reduced or standby operation. Using the **operating switch** on the front panel it is possible to switch to other operating modes, usage times and current operational status levels are displayed in the LCD field.

If **manual operation** is active and if frost protection is inactive, then the menu field **PU** appears where pumps **PU 1** to **PU 4** (symbols in figure at bottom) can be switched.

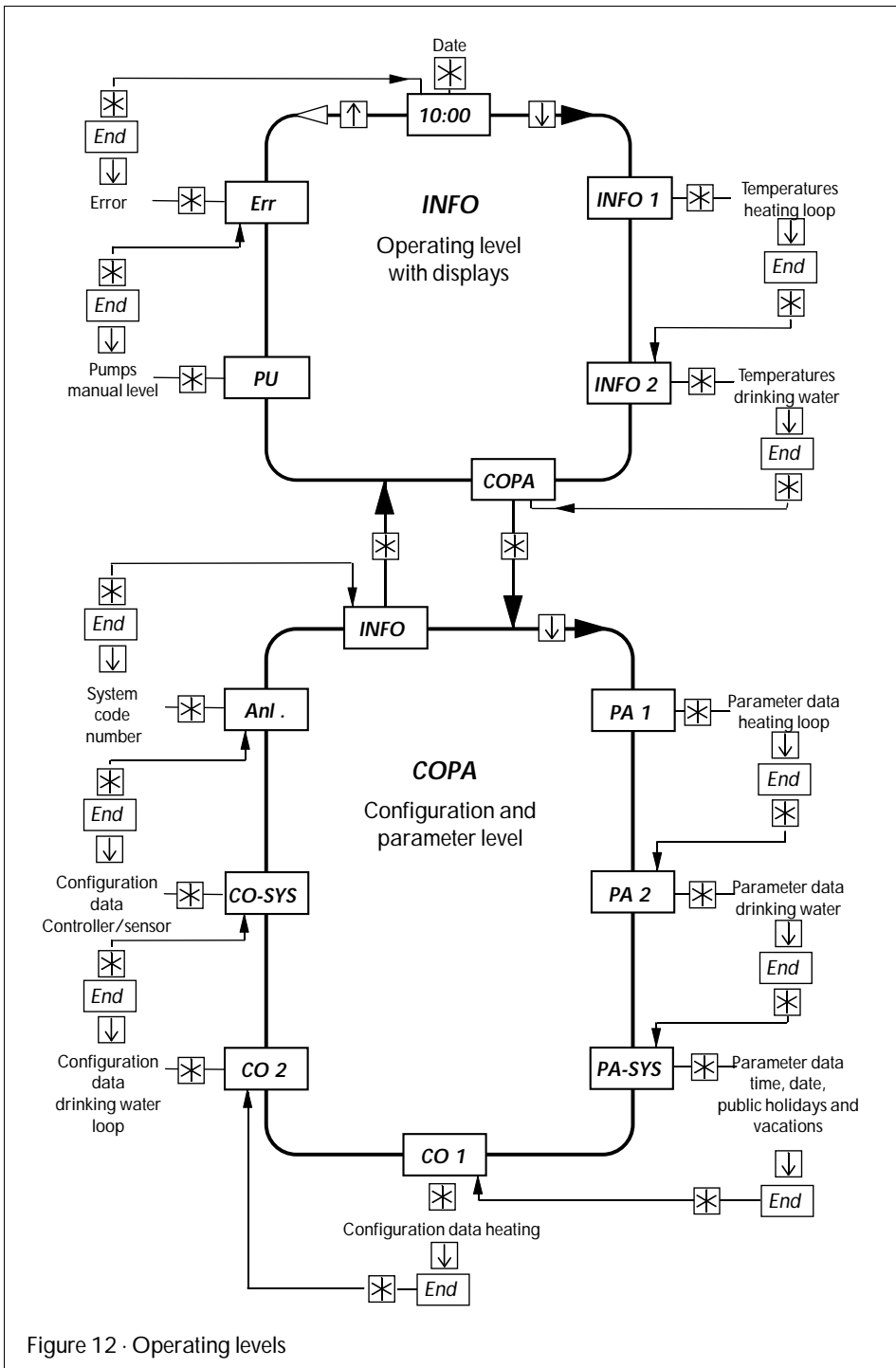



Figure 12 · Operating levels

In the case of an operation error, e.g. a sensor failure, the assigned symbol blinks in the bottom lefthand corner and the menu field **Err** appears. After entering this level the error is displayed, see chapter 4.15.

After connecting the power supply, the basic display with all symbols, the device type **5430**, the firmware release, e.g. **E 1.10**, and the system code number, e.g. **An1 1** appear for 2 seconds at a time.

Then the display with the current time appears and selected symbols from figure 13. Further symbols with their display values and meanings are listed in the tables on the following pages.

To prompt current controller loop data, the appropriate INFO level must be selected via the  key and the data prompt must be sent off by pressing the  key.

If other displays are required, e.g. current temperature values, proceed as follows:









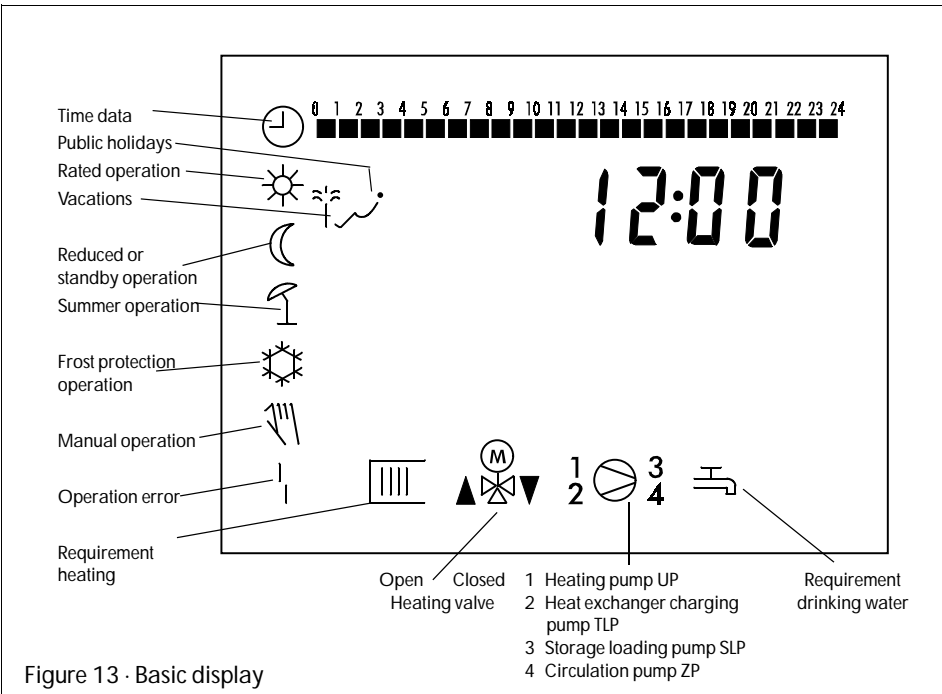







Press the  key, sensor value appears or



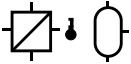

press the  key, the previous screen appears.

If, instead of the current temperature value, the attendant setpoint value is desired, press and hold down the accept key .

Continued pressing of the  key will make further sensor values with different symbols appear. These depend on the system code number entered in the configuration in chapter 7.1 as well as on the set function blocks.



Symbol and display value	Meaning	Remark
 °C	Outdoor temperature	Hold  key down delayed outdoor temperature when CO1 FB 05 = ON
 °C	Flow temperature heating	Setpoint value display: Hold  key down (blinks for return flow limiting)
 °C	Charging temperature	On system 2 and 3 Setpoint value display: Hold  key down
 °C	Return flow temperature	(Only with return flow sensor) Display value blinks when limiting active. Limiting value display: Hold  key down
 °C	Room temperature	(Only with room sensor) Setpoint value display: Hold  key down for adaptation and optimizing operation
 Date	Public holidays	Display only appears if public holidays have been entered. On public holidays the controller reacts as for Sundays. (Heating up of drinking water loop depends on configuration)
 Date	Vacations	Display only appears if vacation periods have been entered. During vacations continuous reduced or standby operation (Switching off of drinking water loop depends on configuration)
 °C	Charging temperature (storage tank flow)	On system 3 and 4 Setpoint value display: Hold  key down display value on system 4 blinks when reverse control active
 °C	Storage tank temperature	On system 2 and 3 with one storage tank sensor
 °C	Differential gap	Display value drinking water requirement ON: Hold  key down

Symbol and display value	Meaning	Remark
 followed by	°C Storage tank temperature top	On system 2 and 3 with two storage tank sensors Display value drinking water requirement ON: Hold  key down
	°C Storage tank temperature bottom	Display value drinking water requirement OFF: Hold  key down

7. Commissioning and adjusting the controller

To commission, switch on the power supply.

After brief intermediate displays, the controller switches to the operating level with the time display.

To adjust the controller, it must first be configured. The desired user data must then be entered under parameter entries in chapter 7.2.

7.1 Configuration

When configuring the controller, the functions of which it is capable must be adapted to the system requirements. First, the appropriate system layout must be selected from figures 7 to 11. Then the functions required for the identified system layout must be determined by selecting certain function blocks.

7.1.1 System code number selection (An1)



Press  until **COPA** appears in the display.

Press  in the top righthand corner **PA 1** appears (parameter for heating loop); then:

Press  until the currently active system code number **An1 1, 2, 3 or 4** appears

If the code number displayed is to be altered:

Press  the display **An1** blinks

Press   and adjust the code number of the selected system layout (An1 1 to An1 4, figures 7 to 11)

Press  thereby accepting the selected system code number, adjust the attendant function blocks as follows

7.1.2 Function block adjustment

When selecting additional sensors and/or functions not contained in the basic setting, these must be taken into account by adjusting corresponding function blocks (ON or OFF). The meaning of the function blocks is detailed in the lists on the following pages.







After adjusting and accepting the system code number

Press  until **CO1** (configuration level for heating loop) appears in the display.

If it is desired to alter the basic function block setting, proceed as follows:

Press  to access the configuration level with the display of the first function block **F01 to 0 or 1**

Additionally, a bar graph with the basic setting of the functions blocks belonging to the adjusted system code number appears in the display (only visible if not all function blocks are set to OFF = 0). Below the number row 1...24, black fields indicate function blocks which are switched on and vacant fields indicate function blocks which are switched off, with the corresponding field to the right and beneath the respective number.

- Press   and adjust the number of the function block in which an alteration is to be made.
- Press  the function block number blinks.
- Press  to switch the function block **on F 01x - 1** or
- Press  to switch the function block **off FOx - 0**
- Press  the setting is accepted, the next function block appears
- Carry out adjustment of other function blocks in the same way.

When selecting function blocks marked in the following table as SZ, a code number will be requested..





Only after the valid code number has been entered will the function block settings and all accompanying parameter and configuration data be accessible.

Code number setting

The code number is on page 55. Cut out or make the code number illegible to prevent access by unauthorized persons.

After the last key entry, a correctly entered code number is valid for all items for 10 minutes.

0 appears in the display

- Press  and hold the key down until the code number is almost reached. Using the
-   keys, adjust in steps
- Press  to accept the code number setting



Safeguarded function blocks are now accessible and can be adjusted in the manner previously described.

Important:

Parameter adjustment is directly linked to switching on of certain function blocks, therefore under all circumstances observe the notes in the function block list.

Parameters which must be set immediately will blink in the display with the corresponding symbol.

If the default value displayed is to be altered:

- Press   keys and adjust to the desired value
- Press  to accept the value.

7.1.3 Function block lists

Function block list for the heating loop (CO1)

FB – Function block SZ – Code number required WE – FB set by manufacturer Anl – System code number					
FB	Function	SZ	WE	Anl	Remark (values in parentheses are default values)
1	Room sensor (RF)		OFF	1,2,3,4	ON: selection 1 = room control device type 5244 2 = standard sensor and potentiometer 1000 to 2000 Ω
2	Optimizing		OFF	1,2,3,4	ON: selection 1: Switch on acc. to outdoor temperature and reduce according to time program. Parameter: pre-heating time 0...360 min. (120) 2: Switch on according to outdoor temperature. Reduce according to room sensor. Parameter: pre-heating time 0...360 min. (120) (only when FB1 = ON) 3: Switching on and off option acc. to room sensor (only when FB1 = ON)
3	Flash adaptation		OFF	1,2,3,4	only when FB 1 ON
4	Characteristic		OFF	1,2,3,4	OFF: characteristic according to gradient ON: characteristic according to 4 points
5	Delayed outdoor temperature adaptation		OFF	1,2,3,4	ON: selection 1 = delay only when outdoor temp. drops 2 = delay always Parameter: 1 to 6 °C/h (3 °C/h) delay
6	Summer operation (time-controlled relaying of outdoor temperature)		OFF	1,2,3,4	ON: parameter: 01.01. 31.12. (01/06) Summer operation period begins 01/01 ... 31/12 (30/09) Summer operation ends 0.0...50.0 (18 °C) outdoor temperature limiting value

Function block list for general configuration (CO 2)

FB	Function	SZ	WE	Anl	Remark
1	Storage tank sensor 1		ON	2,3	OFF: processing storage tank thermostat only OFF when FB2 OFF
2	Storage tank sensor 2		OFF ON	2 3	OFF, when only one SF desired only when CO2 FB1=ON storage tank thermostat: FB1 OFF
3	Master switchover for heating up of drinking water		OFF	3	ON: switchover to sensor behind the heat exchanger for heating up of drinking water (VF 2)

4	Dur. storage tank charging circul. pump runs acc. to time program		OFF	2,3	ON: depending on time program
5	Thermal Disinfection		OFF	2,3	ON: Only when CO2 FB1=ON parameter: 0...7 (3) day of disinfection (0 = daily)
6	Parallel pump operation		OFF	2,3	Selection only for system 2: 1 = parallel pump operation with UP + SLP 2 = trigger changeover valve and UP
7	Public holiday and vacation data valid also for heating up of drinking water		OFF	2,3,4	
8	Charging temperature buildup via return flow sensor when heating loop OFF		ON	2	Only when CO SYS FB 1 = ON
9	Reverse control		OFF	4	ON: parameter: cycle time 60...600 s (300 s)

Function block list for general configuration (CO SYS)

FB	Function	SZ	WE	Anl	Remarks
1	Return flow primary	n	ON	1,2,3,4	Parameter: 0.1...10.0 (1.0) factor return flow temperature limiting
2	Sensor selection		OFF	1,2,3,4	ON: Pt 1000 sensor OFF: PTC sensor
3	Autom. clock reset, summer-/wintertime		ON	1,2,3,4	
4	Manual level locking	n	OFF	1,2,3,4	Manual operation disabled
5	Selection control		ON	1,2,3,4	ON: three-step control Parameter: Kp = 0.1...50.0 (2.0) Tn = 0...999 (120) s Ty = 15...240 s (120) s OFF: on-off control Parameter: differential gap = 1...50 °C (5 °C) min. operating time = 0...600 s (120 s) min. non-operatnl. time = 0...600 s (120 s)
6	Limiting the control deviation for the OPEN signal		OFF	1,2,3,4	ON: only when CO SYS FB5 ON Parameter: 2...10 °C (2 °C) max. control deviation
FB	Function	SZ	WE	Anl	Remarks
7	Release contin. signal	n	OFF	1,2,3,4	



8	Sensor calibration	n	OFF	1,2,3,4	Parameter: temperature value (measured value ± 10 K) for all sensors connected according to current configuration
9	Default values parameter	n	OFF	1,2,3,4	Brief activation of ON position for reset to default values

7.1.4 Sensor calibration

The measured values for all connected sensors can be changed or reset.

When calibrating a sensor the currently displayed sensor value is to be altered in such a way that it coincides with a temperature value (comparison value) measured directly at the measuring location.

The sensor is calibrated in the configuration level CO-SYS in function block F 8.

Press   keys and select menu field CO-SYS

Press  function block F01 appears

Press  until F08 is displayed

Press  function block is accepted. 0 appears in the display



Press  and set code number, see page 55

Press  the code number is accepted, F08 blinks in the display

Press  to switch on FB 8 F08 - 1

Press  the symbol for the outdoor sensor and the related current temperature value appear (at first without calibration)

Press  the displayed sensor value is accepted, the sensor symbol blinks

Press   until the display value coincides with the comparison value

Press  the adjusted temperature value is accepted, the symbol for next sensor is displayed

Press  and calibrate other sensors in the same manner



VF-flow sensor



RF-room sensor



Flow sensor
Heat exchanger
charging loop



AF-outdoor sensor



RF-return flow sensor



SF1 - SF2
Storage tank sensor

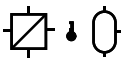

Flow sensor
Storage tank charging loop

At **End** symbol, exit calibration menu by pressing the  key.

Sensor symbols:

7.2 Parameter entries

Depending on the configuration which has now been set up, only system specific parameter items are displayed on the parameter level.

If you are still on the configuration and parameter level **COPA**, press the  key until **PA1** appears in the top right corner of the display to access the parameter item for entry of heating loop data.

Press  to enable data entry on this level



If you are in the information level **INFO** or the operating level, proceed as follows:

Press  until **COPA** appears in the display



Press  **PA1** appears in the top right corner

Press  to enable data entry on this level

Proceed as follows for data entry:

Press   keys to select individual parameter items on the sub-level such as characteristic gradient or level

Press  to accept a parameter item

Press   to alter values and

Press  to accept values

To select other parameter levels:

Press  until the desired level appears

Press  to enable data entry on this level

The following overview in chapter 7.2.2 contains a list of all user-adjustable parameter items. For entry purposes, however, only those parameter items are taken into consideration which correspond to the system configuration determined in chapter 7.1.

7.2.1 Default value adjustment

The function block FB9 on the configuration level CO SYS allows all parameters entered by the user to be reset to the default values (works settings) set at the time of system delivery. (Code number required).

The controller is ready for operation using the default values. However, it requires entry of the current data for time, date and year in the PA SYS level (see also quick instructions inside the cover).

The default values are listed in the following overview.

User guidance in the following chapter requires that, after switching on or after configuration, the controller is on the information level and that the clock setting is in the display!

7.2.2 Entry or modification of user data - overview

Parameter items, screen symbols, default values, remarks

Press  **COPA** appears in the display

Parameter level PA1

Press  to access the COPA level, **PA1** appears in the display

Press  to access the parameter level **PA1**,
the first parameter item for the heating characteristic appears.

Heating characteristics

The default characteristics for flow and return flow have a **gradient value** which can be adjusted accordingly.

If a 4-point setting of the heating characteristic is desired, the function block (**FB4 - 1**) in the configuration level CO1 must be switched on.

Heating characteristic gradient

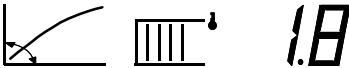

Outdoor and return flow temperature assignment is determined by an inclination value (0.4...3.2).

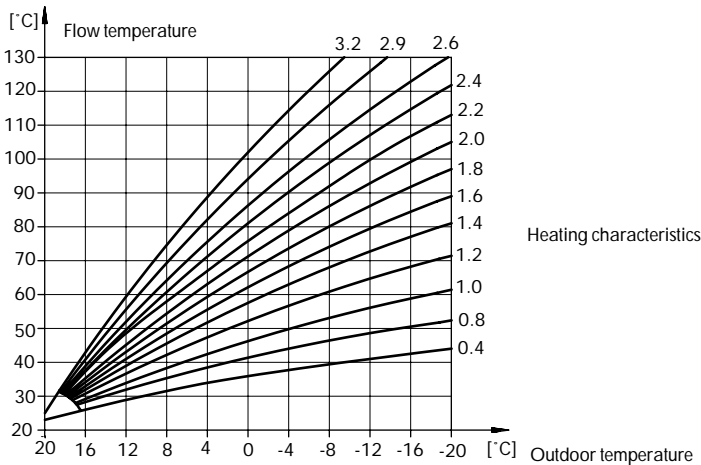

If a modification is desired:

Press  the parameter blinks

Press   and set the desired gradient value

Press  the value is accepted, the next parameter item appears

Heating characteristic level

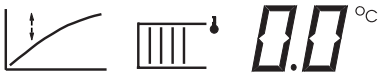

Parallel adjustment of the heating characteristic, upwards (positive value) or downwards (negative value) (-30...+30°C).

If a modification is desired:

- Press the parameter blinks
- Press and enter the desired adjustment value in °C
- Press the value is accepted

Characteristics according to 4 points (CO1 FB 4 = ON)

Press to access parameter level PA1, the menu for the characteristic appears



- Press display the next value or
- Press the symbol blinks
- Press adjust to the desired value
- Press the value is accepted



Points 2 to 4 are entered in the same way. The corresponding point is marked by a square to the right below numbers 1 to 4.

Default setting °C	point 1	point 2	point 3	point 4
Outdoor temperature	-15	-5	5	15
Flow temperature	70	55	40	25
Return flow temperature	65	50	35	20



The reducing temperature at point 2 and point 3 is entered in the same manner. The corresponding point is marked by a square to the right below numbers 2 or 3.

Max. flow temperature



(min. flow temperature up to 130 °C)

Min. flow temperature



(20 °C up to max. flow temperature)

If max. flow temp. = min. flow temp. is set, this results in fixed value control.

Reduction of flow temperature in reduction operation



(0 to 50 °C)

Description, see
Reduced operation, chapter 4.4

Inclination of return flow characteristic



(0.4 to 3.2)

Level of return flow characteristic



(-30 to 30 °C)

Assignment of outdoor and return flow temperature is determined by a gradient value as for flow temperature, see also figure for heating characteristics, page 41.

Max. return flow temperature



(min. return flow temperature up to 90 °C)

Min. return flow temperature



(20 °C up to max. return flow temperature)

If max. return flow temp. = min. return flow temp. is set, this results in a fixed limiting value.

Limiting value of outdoor temperature for return to rated operation during reduction operation



(-30 up to max. outdoor temperature)

Limiting value of outdoor temperature for switching off during reduction operation



(min. outdoor temperature up to 50 °C)

Limiting value of outdoor temperature for summer operation



(0 to 50 °C)

Room setpoint value



Reduced room setpoint value



Sustaining temperature



Only with optimizing, when settings CO1 F 02 = 1 and for flash adaptation F 03 = 1.

Description, see optimizing and flash adaptation, chapters 4.1, 4.2 and 4.4.

Heating utilization periods

A maximum of 3 heating periods may be entered for time-controlled operation (operating switch set to the clock symbol), where the heating automatically switches over from rated operation to reduced operation (see chapter 4.3).

The default setting for daily rated operation is between 0700 and 2200 hrs. During this time period the heating operates according to the preset heating characteristic (see page 41), governed by the outdoor temperature.

In order to save energy during periods of non-use, e.g. at night, the heating switches over to reduced operation at 2200 hrs. During reduced operation the heating operates, for instance, with a flow temperature reduced by 20 °C. (The values for reduced operation are preset as a reduction point, page 42, or reduction during reduced operation, page 43). After reduced operation has ended, the heating switches back to rated operation at 0700 hrs.



From the **COPA** level

Press  to access parameter level **PA 1**

Press  then

Press  until the heating time program is displayed



Time data can be entered in time blocks 1 – 7 (Mo n - Sun), 1 – 5 (Mon - Fri) and 6 – 7 (Sat – Sun) or day-to-day 1 (Mon), 2 (Tue), 3 (Wed) etc. The desired block can be selected using the   keys.

Important: Time blocks entered can only be checked for day-to-day entry.

If, for checking, block type entry is called up, the controller automatically enters default values for the heating times!

For rated operation, periods must be entered alternatively between START and STOP.
 If the 2nd and 3rd time periods are not required, **00:00** should be entered at START and STOP respectively (default setting).
 If START and STOP are set to the same time value, this results in continuous reduction or standby operation (non-usage).

If changes for default time settings are desired:

Press  key to access the entry level for heating loop time data

Time block 1 - 7 is displayed.



1 . . . 7

Press  until time block 1 – 5, time block 6 – 7 or day-to-day entry 1, 2, 3 etc. appears, in order to enter desired times.



If, for instance, the same time data is desired for every day, select block 1 - 7

Press  the block is accepted,

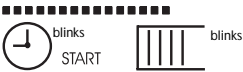

the start of the 1st time period appears in the display. START appears, the clock and heating symbol blink. The currently set time period is additionally displayed in the bar graph.





7:00

Press   and set the start for rated operation (time period 1) (time grid 30 min, bar graph continues to display)



Press  the set value is accepted, STOP appears and the end of the 1st time period (default **22:00**)

Press   and set the end of rated operation (time period 1)

Press  the set value is accepted, START appears and the start of the 2nd time period (default **00:00**)

Press   and set the start of rated operation (time period 2)

Press  the set value is accepted, STOP appears and the end of the 2nd time period (default **00:00**)

Press   and set the end of rated operation (time period 2)

Press  and accept the set value

Data for the 3rd time period is entered as described above.

Then:

Press   and select time block from 1 - 5, 6 - 7 or day-to-day entry

Rated operation for an individual day may be altered again by repeating the entries.

Press  several times, if required, to exit the time program, the display shows pump lag time.



Pump lag time



240 sec

(60 to 600 secs)

Press  the symbol blinks

Press   to alter lag time

Press  and accept the value entered

End appears in the display, heating loop data entry in the parameter level **PA1** is complete

Press  **PA2** appears in the display, the parameter level for entry of data for heating up of drinking water

Parameter level PA2 entries

Drinking water requirement ON



40.0 °C

(20 to 90 °C)

followed by

on system 2 and 3 with only
one storage tank sensor SF1



Differential gap



5.0 °C

(0 to 30 °C)

Press  the symbols blink

Press   set temperature

Press  the value is accepted

Drinking water requirement ON



40.0 °C

(20 to 90 °C)

followed by

on system 2 and 3 with
two storage tank sensors
SF1 and SF2
(CO2 FB 1 = ON, FB 2 = ON)



Drinking water requirement OFF



45.0 °C

(20 to 90 °C)

Press  the symbols blink

Press   set temperature

Press  the value is accepted

Enter the following display values in the same manner.

Charging temperature (return flow setpoint value during heating up of drinking water)



55.0 °C

On system 2, on system 3, 4 without "storage tank" symbol (20 to 90 °C)

Stop charging

Max. value for switching off the storage loading pump on system 2 or TLP on system 3)



48.0 °C

(20 to 90 °C)

Max. value for switching off the storage loading pump on system 3



48.0 °C

(20 to 90 °C)

Heat exchanger limiting temperature during charging



120.0 °C

(20 to 120 °C)
On system 3, when CO2 FB 3 = ON

Return flow limiting temperature during heating up of drinking water



45.0 °C

(20 to 90 °C)
CO SYS FB 1 = ON

After acceptance, the display **0NR** appears.

The code number is required for altering the temperature value! (see page 36)

Time data, heating up of drinking water

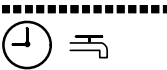

1...7

Default rated operation **1 – 7 00:00 to 24:00**

Entry as for heating usage periods described on page 42.

Time data for circulation pump ZP

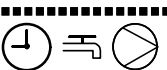

1...7

Default rated operation **1 – 7 00:00 to 24:00**

After acceptance of the last time value, **End** appears in the display. Entry of usage times for heating up of drinking water in parameter level **PA2** is complete.

Press , **PA-SYS** appears in the display, the parameter level for entry of time, date, public holidays and vacations.

Entering current time, date, year as well as public holidays and vacations

After pressing the accept key, from the **PA2** level directly to the **PA-SYS** level or from the **COPA** level

Press  until **PA-SYS** appears



Entries in parameter level **PA-SYS**

Press  a time value is displayed





10:00

Press  the clock symbol blinks

Press   and set the current time

Press  the time is accepted, a date value appears

Press  the clock symbol blinks

Press   and set the current date

Press  the date is accepted, a year value is displayed

Press  the clock symbol blinks

Press  and set the current year

Press  the number is accepted,

the symbol for entry of public holidays appears in the display

Press  to continue to the entry field for vacations or

Press  again to exit entries at **End**.

If values deviating from the default values are to be entered:

Public holidays (max. of 20 days may be entered)





Default: 01/01, 01/05, 25/12 and 26/12

Entering of additional days:

Press  1st default value is displayed

Press  until ---- appears.

Press  public holiday symbol blinks

Press   and set additional public holiday



Press  and accept the date entered

Deleting dates entered:

Press  1st default value is displayed

Press  until public holiday to be deleted appears

Press  public holiday symbol blinks

Press   until ---- appears (between 31/12 and 01/01)

Press  public holiday is deleted

Additional public holidays as previously described

Vacations (max. of 10 periods may be entered)



Default: ----

Entering vacation periods:

- Press start ---- is displayed
- Press vacation symbol blinks
- Press and enter start of vacation period
- Press and accept date vacation symbol blinks, STOP is displayed
- Press and enter end of vacation period
- Press and accept the date entered

Deleting vacation periods:

- Press start of 1st vacation period is displayed
- Press until start of vacation period to be deleted appears
- Press vacation symbol blinks
- Press until ---- appears (between 31/12 and 01/01)
- Press vacation period is deleted

Additional vacation data as previously described.

8. Data sheets

Station
User
Responsible SAMSON office
System code number

Function block settings in the configuration levels								
CO1			CO2			CO SYS		
No.	ON	OFF	No.	ON	OFF	No.	ON	OFF
1			1			1		
2			2			2		
3			3			3		
4			4			4		
5			5			5		
6			6			6		
			7			7		
			8			8		
			9			9		

Heating loop Characteristics and limiting values				
Return flow characteristic according to gradient				
Flow charac. acc. to gradient (0.4 to 3.2) [1.8]				
Level (-30.0 to 30.0) [0.0] °C				
Reduction red. oper. (0.0 to 50.0) [20.0] °C				
Return flow characteristic according to gradient				
RL charac. acc. to gradient (0.4 to 3.2) [1.2]				
Level (-30.0 to 30.0) [0.0] °C				
Characteristic according to 4 points (CO1 FB 4 = ON)				
Point	1	2	3	4
Outdoor temp. (-30 to 50 °C)	[-15.0]	[-5.0]	[5.0]	[15.0]
Flow temp. (20 to 130 °C)	[70.0]	[55.0]	[40.0]	[25.0]
Return flow temp. (20 to 90 °C)	[65.0]	[65.0]	[65.0]	[65.0]
Reduction (0 to 50 °C)	xxxx	[20.0]	[20.0]	xxxx
Max. flow temperature (min. FT to 130.0) [90.0] °C				
Min. flow temperature (20.0 to max. FT) [20.0] °C				
Max. return flow temperature (min. RT to 90.0 °C) [65.0] °C				
Min. return flow temperature (20.0 °C to max. RT) [65.0] °C				
Limiting values outdoor temperature				
Reduction operation (limit rated operation up to 50.0) [10.0] °C				
Summer operation (0.0 to 50.0) [22.0] °C				
Rated ops in red. ops. (-30.0 limit red. ops) [-15.0] °C				
Setpoint values for room temperatures				
Rated operation (10.0 to 40.0) [20.0] °C				
Reduced operation (10.0 to 40.0) [17.0] °C				
Sustained temperature (10.0 to 40.0) [10.0] °C				
Summer operation (CO1 FB 6 = ON)				
Start				
End				
Limiting value outdoor temp. (0.0 to 50.0) [18.0] °C				
Control deviation limiting for OPEN signal (CO SYS FB 6 = ON)				

Limiting value (2.0 to 10.0) [2.0] °C	
---------------------------------------	--

Control parameter	
Kp (0.1 to 50.0) [2.0]	
Tn (1 to 999) [120] s	
Valve running period Ty (15 to 240) [120] s	
Diff. gap 2-point outp. (1.0 to 50.0) [5.0] °C	
Lag time UP (60 to 600) [240] s	

Usage times heating loop (0700 to 2200 hrs)							
	Mon	Tue	Wed	Thu	Fri	Sat	Sun
Start 1							
End 1							
Start 2							
End 2							
Start 3							
End 3							

Public holidays (01/01,01/05,25/12,26/12) [20 days may be entered]							

Vacation periods (----) [10 periods may be entered]							

Heating up of drinking water	
Setpoint values	
Requirement ON (20 to 90) [40] °C	
Requirement OFF (20 to 90) [45] °C	
Differential gap (0 to 30) [5] °C (only when CO2 FB 2 = OFF)	
Charging/setpoint temperature (20 to 90) [55] °C	
TLP OFF (20 to 90) [48] °C	
SLP OFF (20 to 90) [48] °C (only when CO2 FB 3 = ON)	
Return flow limiting (20 to 90) [45] °C	
Max. flow temp. for heating up of drinking water (20 to 120) [120] °C (only when CO2 FB 3 = ON)	

Thermal disinfection	
Daily disinfection (0)	
Weekly disinfection (1 – 7 = Mo – So)	

Usage times heating up of drinking water (0000 to 2400 hrs)							
	Mon	Tue	Wed	Thu	Fri	Sat	Sun
Start 1							
End 1							
Start 2							
End 2							
Start 3							
End 3							

Time data circulation pump (0000 to 2400 hrs)							
	Mon	Tue	Wed	Thu	Fri	Sat	Sun
Start 1							
End 1							
Start 2							

End 2							
Start 3							
End 3							

Code number

1732





SAMSON AG · MESS- UND REGELTECHNIK
Weismüllerstraße 3 · D-60314 Frankfurt am Main
Postfach 10 19 01 · D-60019 Frankfurt am Main
Telephone (0 69) 4 00 90 · Telefax (0 69) 4 00 95 07

EB 5430 EN

S/C 08.97