

Electric Control Valves

Types 3226/5857, 3226/5824, 3226/5825,
3226/5757-7, 3226/5725-7

SAMSON

Pneumatic Control Valves

Type 3226/2780



Type 3226/5857
Type 3226/5757-7



Type 3226/5824



Type 3226/2780-2 · Version with
Type 3760 Positioner

Fig. 1 · Control valves

Mounting and Operating Instructions

EB 5863 EN

Edition October 2010

CE

Contents	Page
1	General safety instructions 3
2	Design and principle of operation 4
2.1	Technical data 6
2.2	Possible combinations 7
2.3	Nameplate 8
2.4	Customer inquiries 8
3	Installation 8
3.1	Mounting position 8
3.2	Strainer 8
3.3	Additional mounting instructions 9
4	Mounting, connecting and configuring the actuator 10
4.1	Mounting 10
4.2	Connection 10
4.3	Configuration 10
5	Maintenance 11
6	Dimensions and weights 12

Definitions of the signal words used in these instructions

WARNING!

indicates a hazardous situation which, if not avoided, could result in death or serious injury.

NOTICE

indicates a property damage message.

Note: *Supplementary explanations, information and tips*

1 General safety instructions

For your own safety, follow these instructions concerning the mounting, start up and operation of the control valve:

- ▶ The control valves must be installed, started up and serviced by fully trained and qualified personnel only, observing the accepted industry codes and practices.
Make sure employees or third persons are not exposed to any danger.
All safety instructions and warnings in these mounting and operating instructions, particularly those concerning installation, start-up and maintenance, must be observed.
- ▶ For appropriate operation, make sure that the control valve is only used in applications where the operating pressure and temperatures do not exceed the operating values based on the sizing data submitted in the order.
Note that the manufacturer does not assume any responsibility for damage caused by external forces or any other external factors.
Any hazards which could be caused in the control valve by the process medium or operating pressure are to be prevented by means of appropriate measures.
- ▶ For installation and maintenance, make sure the relevant section of the pipeline is depressurized and, depending on the process medium, drained as well. If necessary, allow the control valve to cool down or warm up to reach ambient temperature prior to starting any work on it.
- ▶ The actuators are designed for use in low voltage installations.
For wiring and maintenance, you are required to observe the relevant safety regulations.
- ▶ Take necessary measures to ensure that the power supply cannot be reconnected inadvertently.
- ▶ Take care while performing adjustment work on live parts. Never remove any covers!

To avoid damage to any equipment, the following also applies:

- ▶ Proper shipping and appropriate storage are assumed.

Note: The control valves fulfill the requirements of the European Pressure Equipment Directive 97/23/EC. Valves with a CE marking have a declaration of conformity which includes information about the applied conformity assessment procedure.
The declaration of conformity is available on request.

2 Design and principle of operation

The three-way valves in the version with male thread connection and welding ends or threaded ends can be used for both mixing or diverting valves. The valves vary in the plug arrangement and must be installed accordingly. The version with female thread can only be used for mixing valves.

The process medium flows through the three-way valve in the direction indicated by the arrow. The position of the plug (3) determines the cross-sectional area of flow between the plug and the seat (2). The plug stem follows the actuator stem, which is changed by the control signal acting on the actuator, owing to the force of the valve spring (5).

The valve (1) and actuator (8) have a force-locking connection.

Fail-safe position

For three-way valves mounted to an actuator with fail-safe action, the control valve has two different positions which become effective upon power supply failure:

Actuator stem extends

- ▶ Port B of the mixing valve closes upon power supply failure
- ▶ Port A of the diverting valve closes upon power supply failure

Actuator stem retracts

- ▶ Port A of the mixing valve closes upon power supply failure
- ▶ Port B of the diverting valve closes upon power supply failure

Electric actuators

The Types 5857, 5824 und 5825 Electric Actuators can either be controlled using a three-stepping point signal or, in the version with positioner, with continuous signals which can be adjusted in ranges from 0 to 20 mA or 0 to 10 V. Various optional electric accessories can be mounted onto the control valve. The Type 5825 Electric Actuator is able to perform a fail-safe action. Refer to Table 4.

Controllers with electric actuators

The actuator consists of a digital controller which is integrated into the electric actuator housing. The Types 5757-7 and 5725-7 Controllers with Electric Actuators are suited for heating and cooling applications. They are controlled by continuous signals which can be adjusted in ranges from 0 to 20 mA or 0 to 10 V. Type 5725-7 is able to perform a fail-safe action. Refer to Table 4.

Pneumatic actuators

A control signal from 0.4 to 1 bar is used by the Type 2780-1 Pneumatic Actuator and a control signal from 0.4 to 2 bar is used by Type 2780-2 Pneumatic Actuator at the loading pressure connection. The pneumatic actuators require a supply pressure of at least 0.2 bar above the maximum bench range. The actuators are available for fail-safe action "Actuator stem extends (FA)" or "Actuator stem retracts (FE)".

Special versions

- ▶ DVGW-tested version as diverting valve
- ▶ DVGW-compliant version (materials and lubricants same as DVGW-tested version) as mixing valve

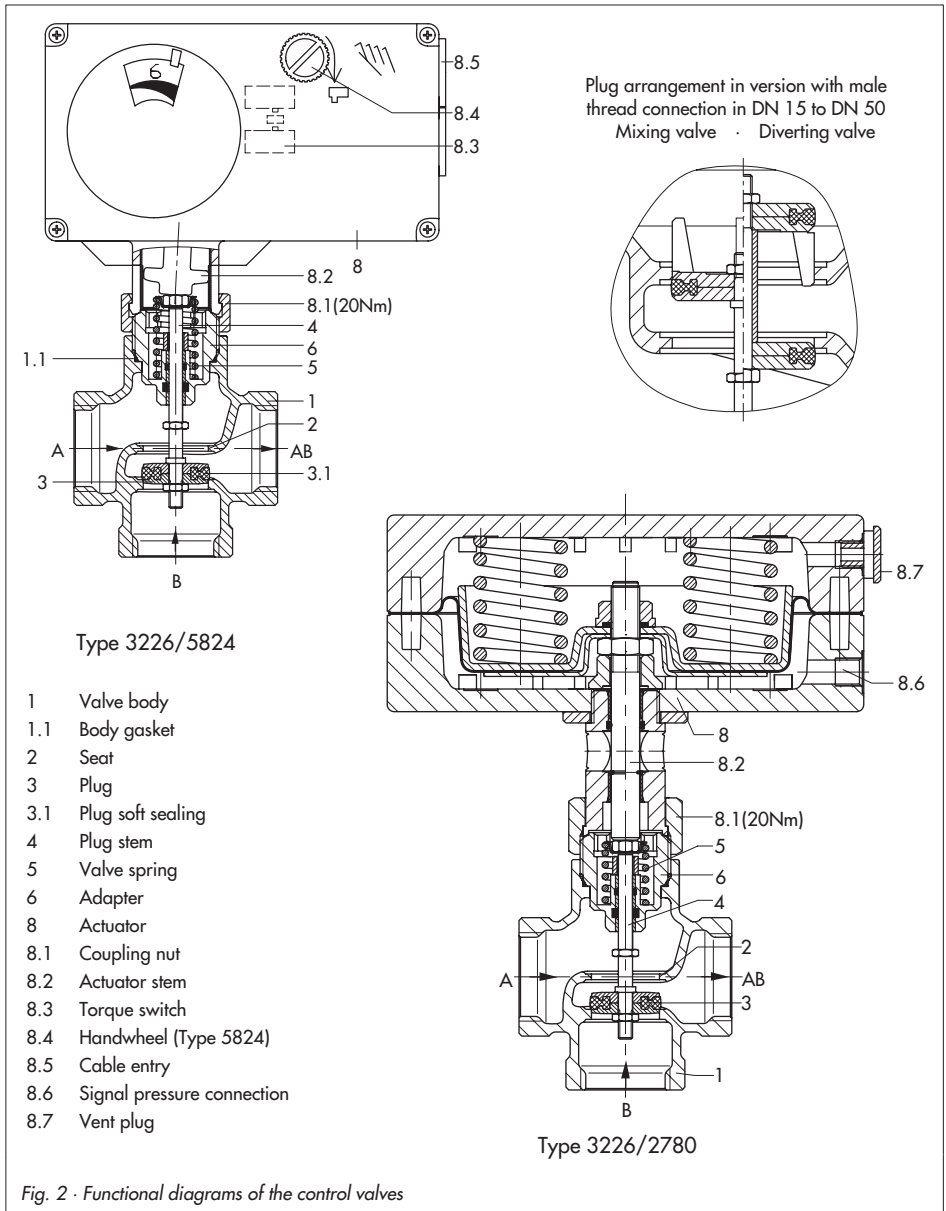

Fig. 2 - Functional diagrams of the control valves

2.1 Technical data

Table 1 · Technical data: Type 3226 Three-way Valve · All pressures in bar (gauge)								
Nominal size	Mixing or diverting valve with male thread	DN	15	20	25	32	40	50
Thread size	Mixing valve with female thread	G	½	¾	1	–	–	–
Nominal pressure		PN	25					
DVGW version		PN	10					
Permissible temperature range		°C	+5 (–15 ¹⁾) to 150 ²⁾					
DVGW version		°C	+5 to 90 °C ³⁾					
Permissible differential pressure for actuators								
Types 5857, 5757-7		bar	4	2.6	1.8	–	–	–
Types 5824, 5825, 5725-7, 2780		bar	4	4	4	1.7	1.1	1.1
Rated travel		mm	6	6	6	12	12	12
Seat/plug sealing	Soft sealing							
Leakage rate acc. to DIN EN 60534-4	Class IV (≤ 0.01 % of the K _{VS} coefficient)							

1) Version for water –15 °C to +5 °C with intermediate insulating piece (1990-1712)

2) Use intermediate insulating piece (1990-1712) in networks with a constant medium temperature between 130 and 150 °C

3) **Special DVGW-tested version:** as diverting valve only

Special DVGW-compliant version (materials and lubricants same as DVGW-tested): as mixing valve only

Table 2 · Materials: Type 3226 Three-way Valve	
Valve body	CC491K (G-CuSn5ZnPb)
Plug	CW617N (CuZn40Pb2zh) with EPDM
Packing	O-rings made of FKM and EPDM
Welding ends	St 37
Threaded ends	Red brass

Table 3 · Nominal sizes and K _{VS} coefficients: Type 3226 Three-way Valve											
Nominal size	Mixing or diverting valve with male thread	DN	15		20	25	32	40	50		
Thread size	Mixing valve with female thread	G	½		¾	1	–	–	–		
K _{VS}			1.0	1.6	2.5	4	6.3	10	16	25	40
Rated travel		mm	6	6	6	6	6	6	12	12	12

2.2 Possible combinations

Table 4 · Possible combinations: Type 3226 Three-way Valve/actuator											
Type	Fail-safe action: Actuator stem		Nominal size DN						Connection size G		
	extends	retracts	15	20	25	32	40	50	½	¾	1
Electric actuators											
5857 ¹⁾	–	–	•	•	•	–			•	•	•
5824-10	–	–	•	•	•	–			•	•	•
5824-13 ²⁾	–	–	•	•	•	–			•	•	•
5825-10	•	–	•	•	•	–			•	•	•
5825-13 ²⁾	•	–	•	•	•	–			•	•	•
5825-15	–	•	•	•	•	–			•	•	•
5824-20	–	–	–			•	•	•	–		
5824-23 ²⁾	–	–	–			•	•	•	–		
5825-20	•	–	–			•	•	•	–		
5825-23 ²⁾	•	–	–			•	•	•	–		
5825-25	–	•	–			•	•	•	–		
Controllers with electric actuators for heating and cooling applications											
5757-7 ¹⁾	–	–	•	•	•	–			•	•	•
5725-710	•	–	•	•	•	–			•	•	•
5725-715	–	•	•	•	•	–			•	•	•
5725-720	•	–	–			•	•	•	–		
5725-725	–	•	–			•	•	•	–		
Pneumatic actuators											
2780-1	•	•	•	•	•	•	•	•	•	•	•
2780-2	•	•	•	•	•	•	•	•	•	•	•

- ¹⁾ The valve spring in the Type 3226 Valve intended for mounting on the Types 5857 and 5757-7 is different from that of the Type 3226 intended for other actuators. Actuators with a larger nominal thrust (e.g. Type 5824) may also be combined with valves for Types 5857 and 5757-7, however, not vice versa.

- ²⁾ Actuator with half transit time

2.3 Nameplate

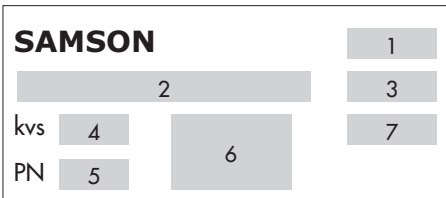

1 Type designation

2 Configuration ID (Var.-ID)

3 Date of manufacture

4 K_{VS} coefficient

5 Nominal pressure

6 Version

Mixing valve Diverting valve

7 Max. perm. temperature

2.4 Customer inquiries

Please submit the following details:

- ▶ Type designation
- ▶ Configuration ID (Var.-ID)
- ▶ Date of manufacture

3 Installation

If the valve and actuator are delivered separately, install the valve into the pipeline and mount the actuator afterwards.

3.1 Mounting position

The valve can be mounted in any desired position. Nevertheless, the electric actuators and controllers with electric actuators must not be mounted in a suspended position.

- ▶ Choose a place of installation where the ambient temperature does not exceed or fall below the permissible limits specified for the actuator. Make sure you can freely access the valve even after the entire plant has been completed.
- ▶ Thoroughly flush the pipeline before installation.
- ▶ Observe appropriate assignment of flow and return flow to ports **A**, **B** and **AB** (Fig. 3).
- ▶ Install a strainer (e.g. SAMSON Type 2 NI) upstream of the valve inlet to prevent that any sealing parts, weld spatter and other impurities carried along by the process medium impair the proper functioning of the valve, above all the tight shut-off.
- ▶ Make sure the valve is mounted free of stress. If necessary, support the piping near the connections.

3.2 Strainer

- ▶ Install a strainer upstream of the valve inlet with the filter element vertically suspended.
- ▶ Remember to leave enough space to remove the filter element.

- ▶ Install the strainer such that the direction of flow corresponds to the arrow.

3.3 Additional mounting instructions

We recommend to install a hand-operated shut-off valve upstream of the strainer and downstream of the control valve to be able to shut down the plant for cleaning and maintenance, and when the plant is not used for longer periods of time.

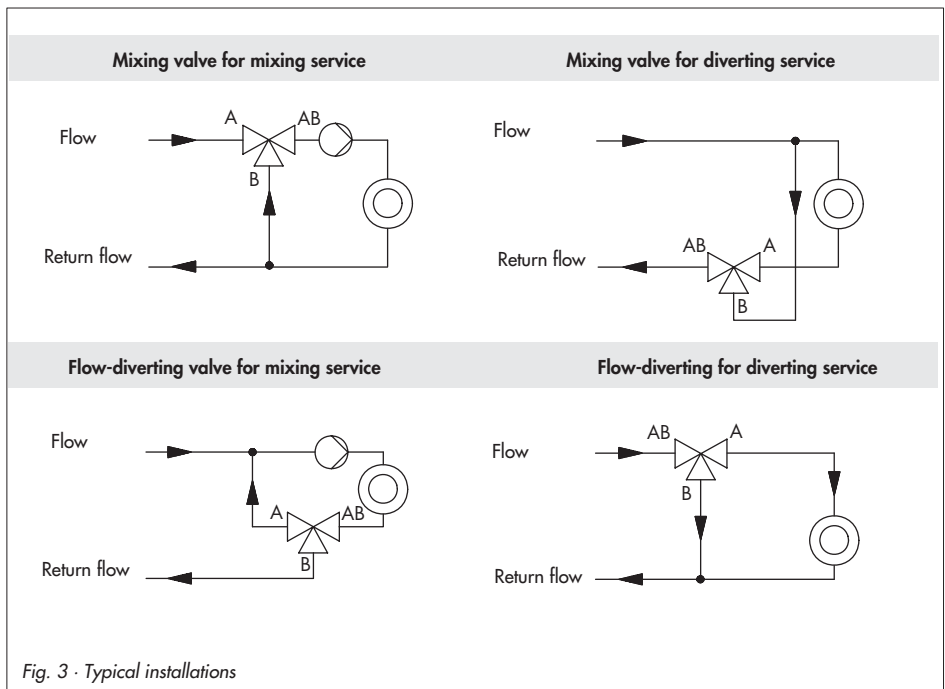

4 Mounting, connecting and configuring the actuator

NOTICE

The instructions to mount the valve onto the actuator, to perform electrical or pneumatic connections as well as to configure the actuator are described in detail in the Mounting and Operating Instructions (EB) of the actuator:

- Refer to EB 5857 EN for Type 5857 Electric Actuator
- Refer to EB 5824-1 EN for Type 5824 Electric Actuator (three-stepping point signal) or EB 5824-2 EN for Type 5824 Electric Actuator (version with positioner)
- Refer to EB 5824-1 EN for Type 5825 Electric Actuator (three-stepping point signal) or EB 5824-2 EN for Type 5825 Electric Actuator (version with positioner)
- Refer to EB 5757-7 EN for Type 5757-7 Controller with Electric Actuator
- Refer to EB 5725-7 EN for Type 5725-7 Controller with Electric Actuator
- Refer to EB 5840 EN for Type 2780 Pneumatic Actuator

It is essential to read the Mounting and Operating Instructions of the corresponding actuator.

4.1 Mounting

Mount the actuator on the valve connection/intermediate insulating piece as described in the corresponding Mounting and Operating Instructions.

4.2 Connection

Perform the electrical or pneumatic connections of the actuator as described in the corresponding Mounting and Operating Instructions.

4.3 Configuration

The electric actuator versions with positioner and the controllers with electric actuator can be adapted to the control task.

Configure the actuator as described in the corresponding Mounting and Operating Instructions.

5 Maintenance

The control valve is subject to natural wear. Depending on the conditions the valve is operated in, it needs to be checked at regular intervals. If leakage to the atmosphere occurs, disassemble the valve and replace damaged parts.

NOTICE

When working on the control valve, make sure the relevant section of the plant has been depressurized and, depending on the process medium, drained as well.

For high medium temperatures, allow the section of the plant to cool down to ambient before starting any work.

Make sure the control signal for the actuator is switched off and the signal pressure line of a pneumatic actuator is removed.

6 Dimensions and weights

Table 5.1 · Type 3226 Three-way Valve							
Valve with male thread connection							
Nominal size	DN	15	20	25	32	40	50
Length L	mm	65	70	75	100	110	130
Height H2	mm	51			61		
Height H3	mm	40	40	40	60	65	65
... with welding ends							
Connection size R	G	¾	1	1¼	1¾	2	2½
Pipe Ød	mm	21.3	26.8	33.7	42	48	60
Width across flats SW		30	36	46	59	65	82
Length L2	mm	210	234	244	268	294	330
Height H4	mm	112	122	124	149	162	175
Weight without actuator	kg	3.2	3.6	4.0	6.1	7.0	8.0
... with threaded ends							
Male thread A	G	½	¾	1	1¼	1½	2
Width across flats SW		30	36	46	59	65	82
Length L3	mm	128	143	158	179	195	227
Height H5	mm	71.5	76.5	81.5	99	108	114
Weight without actuator	kg	3.2	3.6	4.0	6.1	7.0	8.0
Valves with female thread							
Connection size	G	½	¾	1	–		
Length L1	mm	65	75	90	–		
Height H1	mm	40	40	40	–		
Height H2	mm	51			–		
SW1		27	34	46	–		
Weight without actuator	kg	0.9	1.1	1.3	–		

Table 5.2 · Electric actuators				
	Type	5857	5824	5825
Weight	kg	0.7	1.0	.25

Table 5.3 · Controllers with electric actuators		
	5757-7	5725-7
Weight	0.7	1.3

Table 5.4 · Pneumatic actuators		
	2780-1	2780-2
Weight	2	3.2

Electric control valves

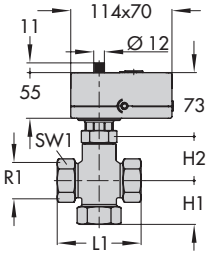

Types 3226/5857, 3226/5757-7
up to DN 25 only
Version with female thread

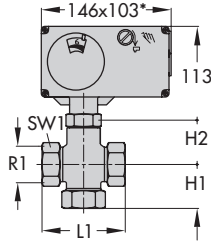

Types 3226/5824-xx,
Types 3226/5825-xx
Types 3226/5725-7xx

* Dimensions for Type 5824-x3 and
Type 5825-x3 Actuators: 146 x 136

Pneumatic control valves

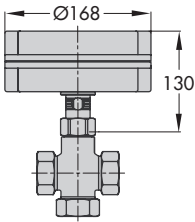

Type 3226/2780-1

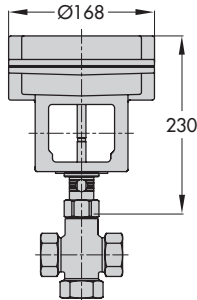

Type 3226/2780-2

Versions

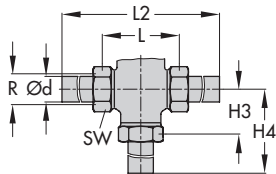

Version with welding ends

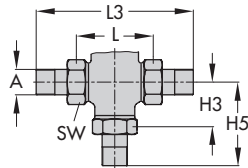

Version with threaded ends



SAMSON AG · MESS- UND REGELTECHNIK
Weismüllerstraße 3 · 60314 Frankfurt am Main · Germany
Phone: +49 69 4009-0 · Fax: +49 69 4009-1507
Internet: <http://www.samson.de>

EB 5863 EN

2010-11