



Fig. 1 · Type 6132-04 rail-mounting unit



Fig. 2 · Type 6132-01 rack-mounting unit

1. Description

1.1 Application

These converters serve as intermediate element to provide transition between pneumatic and electric measuring and control equipment.

The pneumatic input signal ranging from 0.2 to 1 bar (for Type 6132-04 also from 0.4 to 2 bar) is converted into an electric dc or dc voltage signal from 4(0) to 20 mA or 1(0) to 5 V and from 2(0) to 10 V.

Versions

Type 6132-01 rack-mounting unit

Type 6132-04 rail-mounting unit

1.2 Options

Type 6132-01 with limit switch

This converter can be equipped with a limit switch (7) which activates the built-in LED and the relay with floating double-throw contact (8) whenever the limit value is exceeded or not reached.

The operating mode of the LED (LED ON when the limit value is either exceeded or not reached) and the relay (open-circuit or closed-circuit connection) can be chosen by means of jumpers.

The limit value is adjusted through a potentiometer and by means of test sockets that are installed on the front plate.

Type 6132-01 with test sockets

This converter can be equipped with additional test sockets in order to check the pneumatic input signal and the electric output signal during operation.



WARNING

Assembly, start-up and operation of the device may only be performed by trained and experienced personnel familiar with this product.

According to these Mounting and operating instructions, trained personnel is referred to persons who are able to judge the work they are assigned to and recognize possible dangers due to their specialized training, their knowledge and experience as well as their knowledge of the relevant standards.

Any hazards which could be caused by the operating pressure are to be prevented by means of appropriate measures.

Proper shipping and appropriate storage are assumed.

1.3 Technical data according to VDE/VDI 2191 · Pressures in bar (gauge)

Type	6132-01	6132-04
Input	0.2 to 1 bar, overloadable up to 2 bar	0.2 to 1 bar, overloadable up to 5 bar
Output	4 to 20, 0 to 20 mA or 0 to 10, 2 to 10 V	4 to 20, 0 to 20 mA or 0 to 5, 1 to 5 V and 0 to 10 V, 2 to 10 V
Permissible load	≤ 650 Ω at 4 to 20 mA and 0 to 20 mA ≥ 2 kΩ at 1 to 10 V and 0 to 10 V	≤ 750 Ω at 20 mA $\hat{=}$ 15 V ≥ 2 kΩ at 0(1) to 5 V and 0(2) to 10 V
Limit switch Switching capacity Switching current Switching voltage	Double-throw contact (switching contact) max. 300 W 3 A, cos φ = 1 230 V AC	
Power supply	24 V DC (18 to 36 V) 1.5 W	230, 115, 24 V AC (+10 to -15 %) 50/60 Hz 3 VA
Performance ¹⁾		
Characteristic Deviation from characteristic	Output linear to input ≤ 0.2 %	
Hysteresis	≤ 0.1 %	≤ 0.05 %
Dead band	≤ 0.03 %	
Ripple of output signal	≤ 0.5 %	
Temperature influence	≤ 0.2 %/10 K for zero and span	≤ 0.15 %/10 K for zero and span
Power influence	≤ 0.1 %	≤ 0.05 %
	applies to voltage changes within the given limits	
Load influence	≤ 0.1 % in the load range	≤ 0.05 % in the load range
EMC noise emission	EN 5008 Part 1	
EMC noise immunity	EN 50082 Part 2	
Device safety	EN 61010	
Class of protection	I	
Overvoltage category	II	
Degree of contamination	2	
Environmental conditions		
Degree of protection DIN VDE 0450	IP 00	IP 20
Ambient temperature	-20 to +65 °C	-20 to +70 °C
Storage temperature	-40 to +85 °C	
Weight approx. kg	0.35	

¹⁾ Error specifications refer to output span

1.4 Principle of operation (Figs. 3)

The pressure transducer (1) converts the pressure p of the pneumatic input signal into an electric dc voltage signal.

For the Type 6132-01, the pressure transducer is a strain gauge, whereas for Type 6132-04, it is a capacitive sensor.

The dc voltage signal is proportional to the pressure and is amplified to a defined level in the measuring amplifier (3). The lower range value and the measuring span can be adjusted via potentiometers located at the front plate.

The output stage (4) issues a load-independent dc signal of 4 to 20 (0 to 20) mA or a dc voltage signal of 0 to 5 (1 to 5) V or 0 to 10 V (2 to 10 V).

Jumpers and switches are used to select the output signals. The mains transformer (5) and the rectifier (6) supply the converter with power and isolate it from the mains.

Converters with 24 V supply are isolated by means of a dc module. The latter is used instead of the rectifier (6) and the mains transformer (5).

2. Installation

2.1 Mounting

Rack-mounting units are principally supplied as factory-wired 19" racks and form part of a pre-assembled automation unit.

The electric plug connectors correspond with DIN 41 612 (Form F). The built-in pneumatic plug connectors seal the air lines when the converter is removed.

Rail-mounting units are mounted on a top-hat rail according to DIN EN 50 002. These units can be mounted in any position.

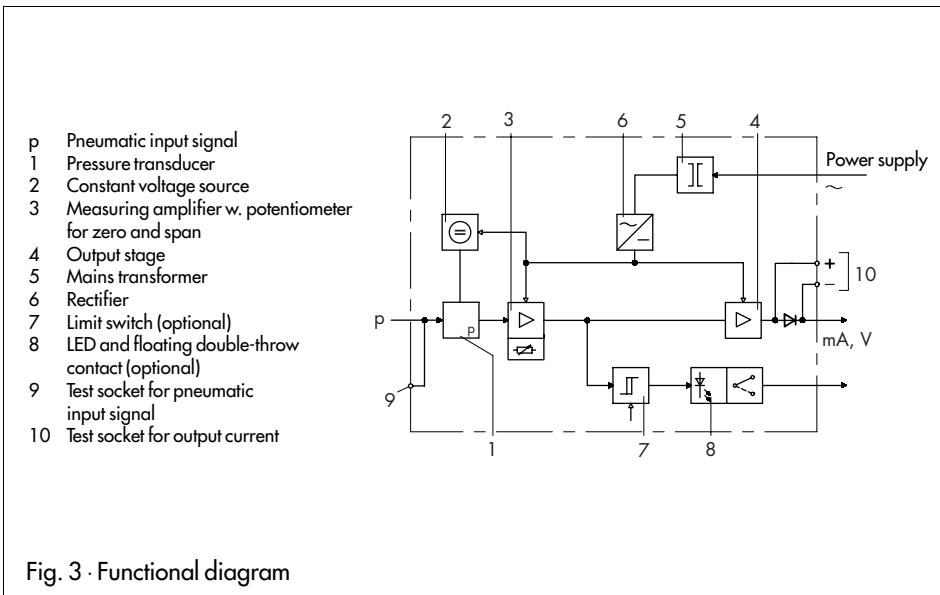

2.2 Electrical connections (Fig. 5)



For electrical installations, you are required to observe the relevant electrotechnical regulations and the accident prevention regulations of your country.

In Germany, these are the VDE regulations and the accident prevention regulations of the employers' liability insurance.

In **rack-mounting units**, the electrical connection is determined by the rack. The electrical connections are also shown below.

In **rail-mounting units**, the wires must be connected to the terminals of the converter. The terminals are designed for wire sizes of 0.5 to 2.5 mm².

The connection lines for voltage supply and the output signal must be installed separately from one another!

Fuses

Rack-mounting units are secured by means of a fuse according to DIN VDE 0820 Part 22 / IEC 127-2.

For 220 V AC = 63 mA, 110 V AC = 100 mA and for 24 V AC and 24 V DC = 315 mA

Rail-mounting units have a self-resetting overcurrent protection.

Rack-mounting units with **test sockets** for checking the output signal have an interlock diode integrated in the output circuit. Thus, you can connect an ammeter with an internal resistance of $R_i \leq 10 \Omega$.

When the output is a voltage signal, a 5 k Ω resistor must be connected between the test socket and the output terminal to provide protection against short-circuit.

To keep the measuring error as small as possible, you should only use voltmeters with an internal resistance of $R_i \geq 5 \text{ M}\Omega$.

2.3 Pneumatic connection

In **rack-mounting units**, the pneumatic connection is determined by the rack.

In converters with **test socket**, the pneumatic input signal can be taken from the self-sealing test socket during operation.

Rail-mounting units have a hose connection for hose sizes of 4 x 1 mm.

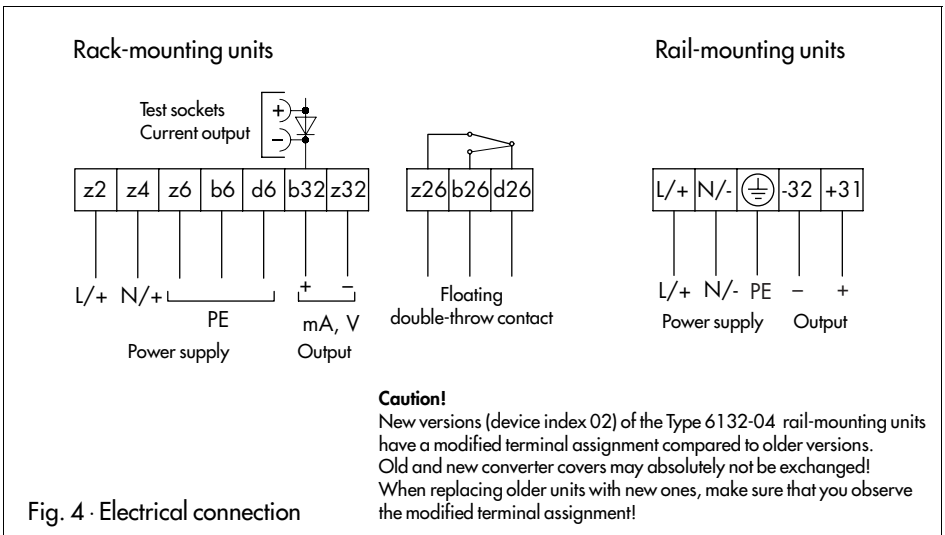

Fig. 4 - Electrical connection

3. Operation

The converter has been tested by the manufacturer and the output signal adjusted to the desired range.

Should you, despite careful assembly, notice any discrepancies which are caused by the converter, you can check zero and measuring span yourself on site.

To do this, isolate the converter from the system. The adjusters for zero and measuring span are easily accessible on the front plate.

Connect the pneumatic input to a pressure transducer and the electric output (Fig. 4) to an ammeter of sufficient accuracy.

3.1 Adjusting the converter

Correcting zero

Adjust the input signal to 0.2 bar (or to 0.4 bar for a signal range of 0.4 to 2 bar).

The ammeter must indicate an output signal of 4(0) mA, or the voltmeter must indicate 2(0) V.

If any deviations occur, use the potentiometer for zero to correct them.

Correcting the measuring span

When increasing the input signal of the converter from 0.2 (0.4) to 1 (2) bar, the associated output signal must read 20 mA on the ammeter or 10 V on the voltmeter.

If any deviations occur, use the potentiometer for measuring span to correct them.

At the end of this procedure, check again for zero and measuring span and correct them once more, if necessary.

3.2 Converting the output signal

The output signal of the converter can be subsequently changed from a current signal to a voltage signal or vice versa.

You also have the possibility of shifting the lower range value.

After having converted the output signal, check the output signal as described in chap. 3.1 and correct it, if necessary.

3.2.1 Rack-mounting units

The output signal depends on how the jumpers (plug-in locations 8 to 19, OUTPUT) are arranged on the push-on terminal strip ST3 of the printed circuit board.

If additional test sockets are installed on the front plate, the plug-in locations 1 to 6 (TEST SOCKET) must also be occupied.

To access the PCB, unthread the four screws at the front and the rear. Then, pull off the front plate together with the lateral cover.

Select the desired signal and the desired range by placing the jumpers correspondingly, as indicated in Table 1.

3.2.2 Rail-mounting unit

The switch S1, the slide switches S1.1 and S1.2 and also the rotary switch S2 which are all located on the PCB determine the output signal.



Caution!

Disconnect voltage!

To access the PCB, lever off the plate with the pneumatic connection using a small screwdriver (plate is clamped into the housing).

Take out the electronics section.

Pre-select the desired output signal by turning the switch S2 clockwise ⌚ to obtain a current signal or counterclockwise ⌚ to obtain a voltage signal.

Then, determine the range by switching on or switching off the switches S1.1 and S1.2 as shown in Table 3.

Table 1 · Push-on terminal strip ST3 (rack-mounting unit)						
Output signal	Version w. test sockets		Jumpers at			
	0 to 10 V	2-3	5-6	8-9	11-12	14-15
2 to 10 V	2-3	5-6	9-10	11-12	14-15	17-18
0 to 20 mA	1-2	4-5	8-9	12-13	15-16	18-19
4 to 20 mA	1-2	4-5	9-10	12-13	15-16	18-19

Table 2 · Push-on terminal strip ST2 (rack-mounting unit)		
	Jumpers at	
	Closed-circuit current	Working current
LED	1-2	2-3
Relay	5-6	4-5

Table 3 · Switch S1 and S2 (rail-mounting unit)				
Output signal	Current [mA]	Voltage [V]		
Switch	S2 – position ☉	S2 – position ☉	S1 – S1.1 and S1.2	
	0 to 20	0 to 10	S1.1 = ON	S1.2 = OFF
	4 to 20	2 to 10	S1.1 = OFF	S1.2 = OFF
		0 to 5	S1.1 = ON	S1.1 = ON
		1 to 5	S1.1 = OFF	S1.1 = ON

3.4 Limit signal

(only for rack-mounting units with limit switches)

If you want the converter to signalize a limit value when a certain output signal is generated, proceed as follows:

Use the push-on terminal strip ST2 on the PCB to determine whether the LED should be on or off when the limit value is reached and also whether the relay should close or open.

For open-circuit connection or closed-circuit connection, use the jumpers and refer to Table 2.

Adjusting the limit value $\sqrt{\quad}$

Adjust the limit value to a voltage signal between 0 and 10 V via the potentiometer $\sqrt{\quad}$.

The value to be adjusted is a percentage value (0 to 10 V = 0 to 100 %) and is referred to the output signal of the converter.

Assuming that a limit value should be signalized at 85 % of the output signal, adjust the potentiometer $\sqrt{\quad}$ such that a voltmeter connected to the test sockets $\sqrt{\quad}$ indicates 8.5 V.

The additional test sockets \oplus enable to check the measured value (0 to 10 V = 0 to 100 %) during operation.

4. Dimensions in mm

Rack-mounting units

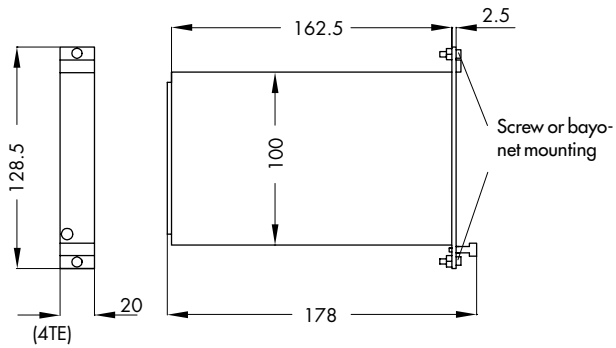

Rail-mounting units

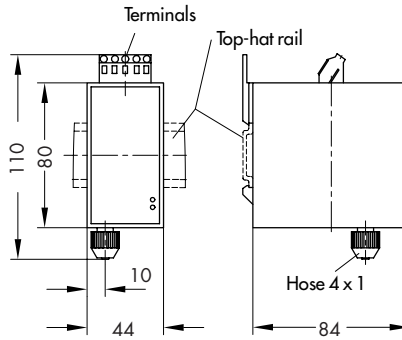

SAMSON AG · MESS- UND REGELTECHNIK
Weismüllerstraße 3 · D-60314 Frankfurt am Main
Telefon (0 69) 4 00 90 · Telefax (0 69) 4 00 95 07
Internet: <http://www.samson.de>

EB 6132 EN

S/C 12.98