

System 6000 Electropneumatic Converters for Pneumatic Signals Type 6134 p/i Converter

for two-wire connection

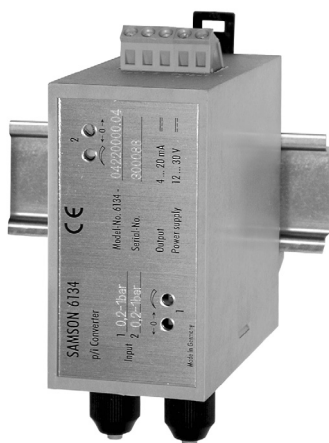

Fig. 1 · Type 6134-04 p/i Converter with one or two p/i converter units, rail-mounting unit



Fig. 2 · Type 6134-x3 p/i Converter, field unit

Mounting and Operating Instructions

EB 6134 EN

Edition October 2008



| Contents | | Page |
|----------|--|------|
| 1 | Description | 4 |
| 1.1 | Application | 4 |
| 1.2 | Versions | 4 |
| 1.3 | Technical data | 5 |
| 1.4 | Principle of operation | 6 |
| 2 | Installation | 7 |
| 2.1 | Mounting position | 7 |
| 2.2 | Mounting | 7 |
| 2.3 | Electrical connection | 7 |
| 2.4 | Pneumatic connection | 8 |
| 3 | Operation | 10 |
| 3.1 | Correcting zero | 10 |
| 3.2 | Correcting the span | 10 |
| 4 | Dimensions in mm | 11 |
| 5 | Servicing explosion-protected devices | 12 |
| | Certificate of conformity | 13 |



General safety instructions

- ▶ *The device is to be mounted, started up or operated only by trained and experienced personnel familiar with the product. According to these mounting and operating instructions, trained personnel is referred to as individuals who are able to judge the work they are assigned to and recognize possible dangers due to their specialized training, their knowledge and experience as well as their knowledge of the applicable standards.*
- ▶ *Explosion-protected versions of this device are to be operated only by personnel who have undergone special training or instructions or who are authorized to work on explosion-protected devices in hazardous areas.*
- ▶ *Proper shipping and appropriate storage are assumed.*
- ▶ **Note:** *The device with a CE marking fulfils the requirements of the directives 94/9/EC and 89/336/EEC.
The declaration of conformity is available on request.*

1 Description

1.1 Application

The converters are used as intermediate elements between pneumatic and electric measuring and control equipment. The standardized pneumatic input signal



between 0.2 bar and 1 bar is converted into an electric DC signal between 4 mA and 20 mA. Other ranges are available on request.

1.2 Versions

| Order no. | 6134- | X | X | X | X | X | X | X | X | X |
|------------------------------------|------------------------------|---|---|---|---|---|---|---|---|---|
| Explosion protection | | | | | | | | | | |
| Without | | 0 | | | | | | | | |
| ⊗ II 2G EEx ia IIC T6 acc. to ATEX | | 1 | 3 | | | | | | | |
| ⊗ II 2G EEx d IIC T6 acc. to ATEX | | 2 | 3 | | | | | | | |
| Housing | | | | | | | | | | |
| Field unit | | | 3 | 0 | | | | | | |
| Rail-mounting unit | with one p/i converter unit | 0 | 4 | 1 | | | | | | |
| | with two p/i converter units | 0 | 4 | 2 | | | | | | |
| Input | | | | | | | | | | |
| 0.2 bar to 1 bar | | | | | 1 | | | | | |
| 3 psi to 15 psi | | | | | 2 | | | | | |
| Electrical connection | | | | | | | | | | |
| Rail-mounting unit | Screw terminals | 0 | 4 | | | 0 | | | | |
| Field unit | ½ - 14 NPT | | 3 | 0 | | 1 | | | | |
| | M 20 x 1.5 | | 3 | 0 | | 2 | | | | |
| Pneumatic connection | | | | | | | | | | |
| Hose connection | | 0 | 4 | | | 0 | 0 | | | |
| ¼ - 18 NPT | | | 3 | 0 | | | 1 | | | |
| ISO-228/1 - G ¼ | | | 3 | 0 | | | 2 | | | |
| Degree of protection | | | | | | | | | | |
| IP 20 | | 0 | 4 | | | 0 | 0 | 0 | | |
| IP 54 | | | 3 | 0 | | | | 1 | | |
| IP 65 | | | 3 | 0 | | | | 2 | | |
| Output pressure gauge | | | | | | | | | | |
| Without | | | | | | | | | 0 | |
| With | | | 3 | 0 | | | | | 1 | |
| Temperature range | | | | | | | | | | |
| T _{min} ≥ -20 °C | | | | | | | | | | 0 |
| T _{min} ≥ -40 °C | | | 3 | 0 | | | | | | 1 |

1.3 Technical data

All pressures as gauge pressures. Other pressures on request.

| p/i Converter | Type | 6134-04 | 6134-03, -13, -23 |
|---|------|--|---|
| Version | | Rail-mounting unit | Field unit |
| Explosion protection acc. to ATEX (94/9/EC) | | - |  II 2G EEx ia IIC T6  II 2G EEx d IIC T6 |
| p/i converter units per device | | 1 or 2 | 1 |
| Input | | 0.2 to 1.0 bar (3 to 15 psi), can be overloaded up to 5 bar (72.5 psi) | |
| Output | | 4 to 20 mA ^{1), 2)} | |
| Permissible load at 0(4) to 20 mA | | $R_B = \frac{U_s - 12 V}{20 \text{ mA}}$, $U_s = \text{supply voltage}$ | |
| Power supply | | Two-wire circuit 24 V ₋ , voltage range 12 to 30 V ₋ ^{1), 2)} | |
| Performance | | | |
| Characteristic | | Output linear to input | |
| Deviation from terminal-based conformity | | For limit point setting: $\leq 0.2\%$ ³⁾ | |
| Hysteresis | | Negligible | |
| Ripple of output signal | | $\leq 0.5\%$ ³⁾ | |
| Temperature influence | | For zero and span: $\leq 0.15\%/10 \text{ K}$ ³⁾ | |
| Power supply and load influence | | - | |
| EMC noise emission | | EN 61000-6-3 | |
| EMC noise immunity | | EN 61000-6-2 | |
| Ambient conditions | | | |
| Degree of protection DIN EN 60529 | | IP 20 | IP 54/IP 65 |
| Ambient temperature | | -20 to 70 °C | Without explosion protection: -20 to 70 °C -40 to 70 °C (only with IP 65) Explosion protection ²⁾ : -20 to 60 °C -40 to 60 °C (only with IP 65) |
| Storage temperature | | -40 to 80 °C | -40 to 80 °C |
| Weight | | 1 converter unit: 0.225 kg 2 converter units: 0.285 kg | 1.005 kg |

1) Type 6134-13: intrinsically safe power circuit

2) For details (electric data, connection conditions etc.) refer to EC type examination certificate

3) Errors relating to output span

Description

| Connections and installation | Type 6134-04 | Types 6134-03, -13, -23 |
|--------------------------------|---|---|
| Mounting position | Any | Exhaust faces downward |
| Pneumatic connection (input) | Hose connection for 4 x 1 mm hose, outside \varnothing 6 mm | 2 x tapped hole (use optionally on left or right): ISO 228/1 - G 1/4 or 1/4 - 18 NPT |
| Electrical connection (output) | Terminals for 0.5 to 2.5 mm ² wires Rigid cable: 0.2 to 4 mm ² Flexible cable: 0.2 to 2.5 mm ² | Female thread: M 20 x 1.5 or 1/2 - 14 NPT, Internal: terminals for 0.5 to 2.5 mm ² wires Rigid cable: 0.2 to 4 mm ² Flexible cable: 0.2 to 2.5 mm ² |
| Mounting | 35-mm-wide top-hat rail, DIN EN 60715 | Bracket for wall mounting (included in scope of delivery) or clamp for mounting to 2" pipe, 1400-5656 |

1.4 Principle of operation (Fig. 3)

The pressure p of the standardized pneumatic signal is converted into an electric DC voltage signal by a capacitive ceramic pressure sensor (1). The DC voltage signal, which is proportional to the pressure, is amplified to a defined level by the amplifier (3).

Both the lower range value and span can be adjusted using potentiometers. The constant voltage source (2) supplies the DC voltage at a constant level. Control equipment can be connected to the output circuit.

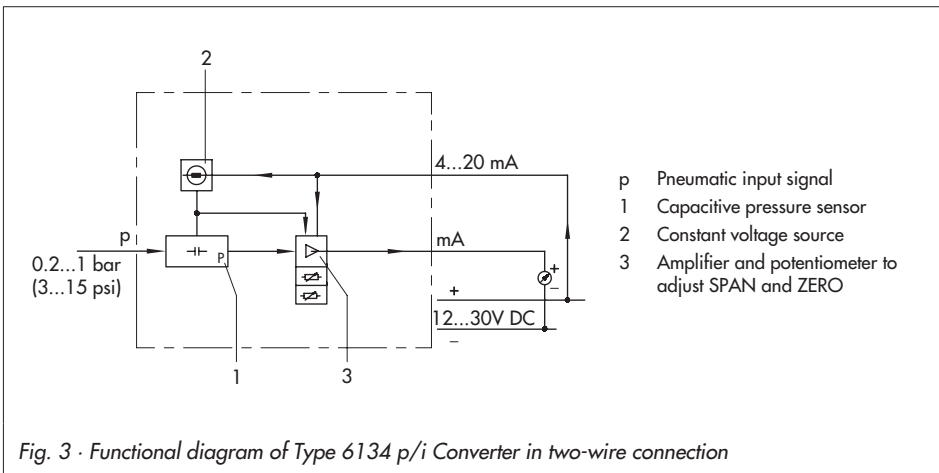

Output circuit:

In a two-wire circuit, the maximum permissible load impedance at the output is calculated as follows:

$$U_B = U_S - U_A \quad R_B = U_B / 20 \text{ mA}$$

U_B Max. permissible load impedance

R_B Max. permissible load

U_S Supply voltage of the two-wire circuit

U_A 12 V, minimum required input voltage of Type 6134

Example: $U_S = 20 \text{ V DC}$

Max. permissible load impedance at output:

$$U_B = 20 \text{ V} - 12 \text{ V} = 8 \text{ V}$$

Load: $R_B = U_B / 20 \text{ mA} = 400 \Omega$

2 Installation

2.1 Mounting position

Rail-mounting units: any desired position

Field units: mounted in horizontal position with the pressure gauge (or stopper plug) facing upward – cable entry at the bottom. With IP 54, the stopper plug must always face downward, at a 90° angle to the floor.

2.2 Mounting

Rail-mounting units: attached to 35 mm top-hat rail according to DIN EN 60715

Field units: attached with mounting bracket (included in scope of delivery) to a wall. A clamp (order no. 1400-5656) is required for attachment to 2" pipes.

2.3 Electrical connection (Fig. 4)



For electrical installation, you are required to observe the relevant electrotechnical regulations and the accident prevention regulations that apply in the country of use. In Germany, these are the VDE regulations and the accident prevention regulations of the employers' liability insurance. The following regulations apply for installation in hazardous areas: EN 60079-14:2003; VDE 0165 Part 1:1998 "Electrical apparatus for explosive gas atmospheres" and EN 50281-1-2; VDE 0165 Part 2:1999 "Electrical apparatus for use in the presence of combustible dust".

The maximum permissible values specified in the EC type examination certificate (U_i or U_o , I_i or I_o , P_i or P_o , C_i or C_o , and L_i or L_o) apply when connecting intrinsically safe equipment.

Caution! The terminal assignment specified in the certificate must be adhered to! Switching the assignment of the electrical terminals may cause the explosion protection to become ineffective!

Do not loosen enameled screws in or on the housing.

- ▶ Screw off the cover of the case. Connect the wires for the input signal to terminals 11 (+) and 12 (-) using suitable screw glands or connectors.
- ▶ Secure grounding conductor at the ground terminal located either inside or outside the case.

The terminals are designed for wires in sizes between 0.5 mm² and 2.5 mm².

Make sure the lines for the voltage supply and the output signal are installed separately.

EEx d versions must be connected using an approved metal cable entry (certificate of conformity) or a seal box pipe. Versions with a certificate of conformity are to be equipped with permanently sealed cable entries.

2.4 Pneumatic connection (Fig. 5)

Note!

Make sure the supply air is free of oil and dust. Observe the maintenance instructions for connected pressure reducing stations. Thoroughly blow out all air connections before attachment.

Note!

When extending the exhaust by connecting a pipe either to the exhaust angle piece or directly to the G or NPT connection, make sure that no water can enter at the end of the pipe. The pipe must have a sufficiently large cross-sectional area of at least 28 mm² = 6 mm inside diameter.

For **rail-mounting units**, the connection is designed as a 4 x 1 mm hose connection.

For **field units**, bores with ISO 228/1 G 1/4 or 1/4 - 18 NPT tapped holes are available. Common screw-in fittings for metal pipes or plastic hoses can be used.

Rail-mounting unit

* Only assigned in devices with second p/i converter unit

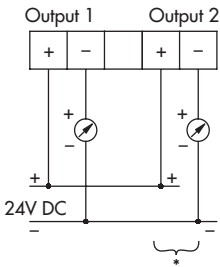

Field unit

* Intrinsically safe circuit (see EC type examination certificate) in explosion-protected versions (Ex ia)

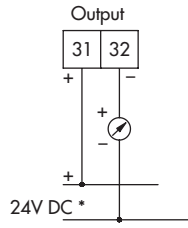
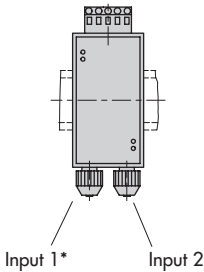

Fig. 4 · Electrical connection (two-wire connection)

Rail-mounting unit

* In version with only one p/i converter unit (Type 6134-041), only Input 1 is assigned



Field unit

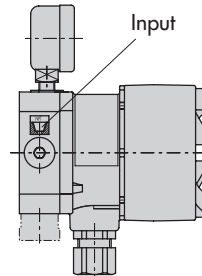

Fig. 5 · Pneumatic connection

3 Operation



Caution!

Never open flameproof devices when energized. Observe the explosion protection regulations! Damage to the thread of the cover and/or the connection thread cause the EEx d protection to become ineffective.

The manufacturer has checked the converter and set the output signal to the required range. Customers can check zero and span when settings are incorrect despite careful mounting. The ZERO and SPAN adjusters (Fig. 6) are located directly on the front panel of the rail-mounting unit. In the field unit, the adjusters can be accessed after the case cover has been removed. Disconnect the converter from the system before checking the settings.

- ▶ Connect the pneumatic input to the pressure transducer and the electric output (Fig. 4) to an adequately precise measuring instrument.

3.1 Correcting zero

Set the input signal to 0.2 bar using a pressure transducer. The measuring instrument for the output signal must read 4 mA. Correct any deviations using the **ZERO** potentiometer.

Note!

Since zero and the upper range value influence each other, check both values again and correct them, if necessary.

3.2 Correcting the span

Span corrections are not influenced by zero adjustments.

If the input signal of the convert is increased from 0.2 bar to 1 bar, the associated output signal on the measuring instrument must read 20 mA.

Correct any deviations using the **SPAN** potentiometer.

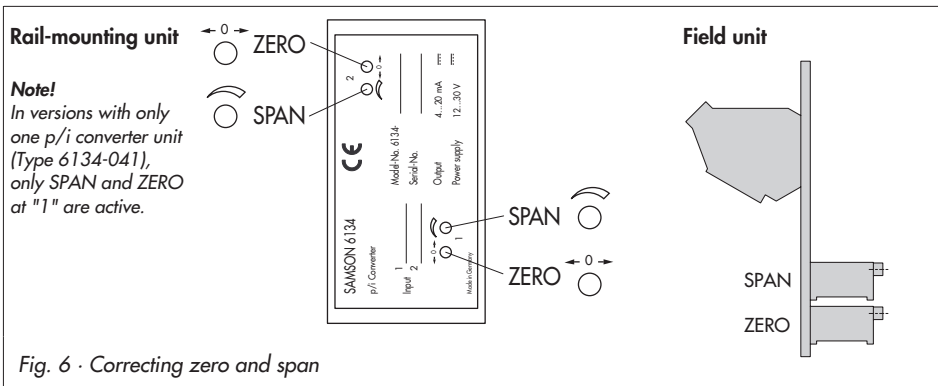

4 Dimensions in mm

Rail-mounting unit

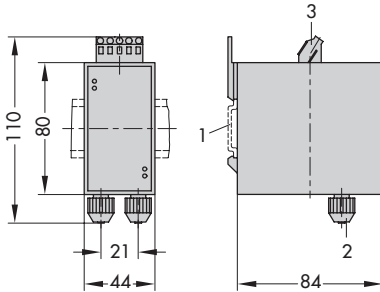

- 1 Top-hat rail
- 2 Pneumatic connection (input)
- 3 Electrical connection (output)
- 4 Clamp for pipe mounting (order no. 1400-5656)
- 5 Bracket for wall mounting, included in scope of delivery (order no. 1400-8837)
- 6 Exhaust IP 54/IP 65
- 7 Pressure gauge (order no. 1400-8838)

* Can optionally be used on the left or the right

Field unit

- Mounting on 2" pipes (bottom)
- Wall mounting (right)

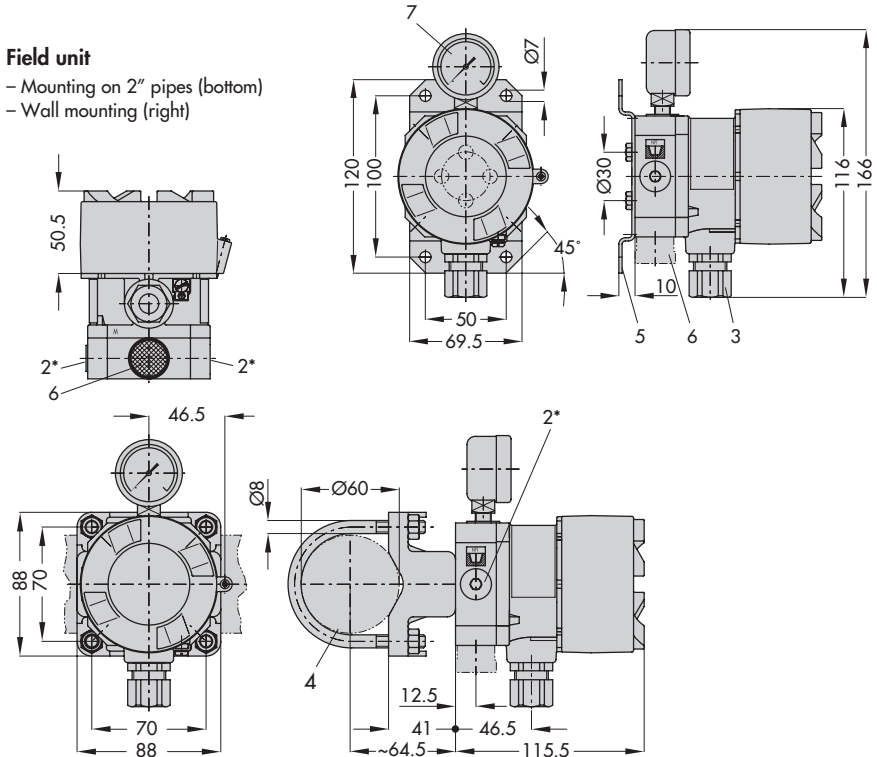

5 Servicing explosion-protected devices

If a part of the converter on which the explosion protection is based needs to be serviced, the converter must not be put back into operation until an expert has inspected it according to explosion protection requirements, has issued a certificate stating this or given the device a mark of conformity.

Inspection by an expert is not required if the manufacturer performs a routine test on the device prior to putting it back into operation. The passing of the routine test must be documented by attaching a mark of conformity to the device.

Explosion-protected components are to be replaced by original, routine-tested components from the manufacturer only.

Devices that have already been used outside hazardous areas and are intended for use inside hazardous areas in the future must comply with the safety requirements placed on repaired devices. Before being used inside hazardous areas, the devices must be tested according to the specifications stipulated under "Servicing explosion-protected devices."



TRANSLATION

EX TYPE EXAMINATION CERTIFICATE

- (1) Equipment and Protective Systems Intended for Use in Potentially Explosive Atmospheres – Directive 94/9/EC
- (2) EC Type Examination Certificate Number
- (3) **PTB 03 ATEX 1214**
- (4) Equipment: Model 6134-2... P/I-Converter
- (5) Manufacturer: SAMSON AG Mess- und Regeltechnik
- (6) Address: Weismüllerstr. 3, 60314 Frankfurt am Main, Germany
- (7) The equipment and any acceptable variation thereof are specified in the schedule to this certificate.
- (8) The Physikalisch-Technische Bundesanstalt, notified body number 0102, according to the European Commission Decision of 23 March 1994, certifies that this equipment has been found to comply with the essential health and safety requirements relating to the design and construction of equipment and protective systems intended for use in potentially explosive atmospheres specified in Annex II to the Directive.

The examination and test results are recorded in confidential report

PTB Ex. 03-13388

- (9) The essential health and safety requirements are satisfied by compliance with **EN 50014:1997 + A1 + A2 EN 50018:2000 + A1**
- (10) If the sign "PC" is placed after the certificate number, it indicates that the equipment is subject to special conditions for safe use as specified in the schedule to this certificate.
- (11) This EC Type Examination Certificate relates only to the design and examination of the specified equipment in compliance with Directive 94/9/EC. Further requirements of this Directive apply to the manufacture and supply of this equipment. These requirements are not covered by this Certificate.

Statement of Conformity without signature and seal is invalid.
This Statement of Conformity may be reproduced only in its entirety without any changes.
Errors or changes shall require the prior approval of the Physikalisch-Technische Bundesanstalt.
Physikalisch-Technische Bundesanstalt Bundesallee 100 D-38116 Braunschweig **PTB-03-134_2.doc**



- (12) The marking of the equipment shall include the following:



Zertifizierungsstelle Explosionsschutz Braunschweig, 06. November 2003
By order

(Signature) (Seal)

Dr.-Ing. H. Wehinger
Direktor und Professor

Statement of Conformity without signature and seal is invalid.
This Statement of Conformity may be reproduced only in its entirety without any changes.
Errors or changes shall require the prior approval of the Physikalisch-Technische Bundesanstalt.
Physikalisch-Technische Bundesanstalt Bundesallee 100 D-38116 Braunschweig **PTB-03-134_2.doc**

S c h e d u l e

- (13)
- (14) **EC Type Examination Certificate No. PTB 03 ATEX 1214**

(15) **Description of Equipment**

The Model 6134-2... P/I converter serves for converting a pneumatic standard signal into a pressure-proportional current signal of 4 to 20 mA in the output circuit. The converter consists of a capacitive ceramic pressure sensor with downstream transducer electronics for amplification and conversion into the 4 to 20 mA standard signal.

Technical data

Input pressure max. 2 bar
Supply voltage 10 to 30 V DC
Signal circuit 4 to 20 mA

- (16) Test report **PTB Ex_03-13388**

(17) **Special conditions**

None

Additional notes on safe operation

Connection requirements

- The Model 6134-2... P/I Converter shall be connected via cable entries or conduit systems suitable for the purpose and which satisfy at least the requirements of the standards specified on the first page and for which a separate certificate has been issued. It is mandatory that the conditions for use of the components specified in the applicable certificates are complied with.
- Cable entries (M20 x 1.5 or NPT glands) and closing plugs of the simple type shall not be used. Where the Model 6134-2... P/I Converter is connected via a conduit entry approved for this purpose, the associated sealing device shall be applied directly on the enclosure.
- Apertures not used shall be closed in compliance with EN 50018 Clause 11.9
- The connecting lead of the Model 6134-2... P/I Converter shall be installed rigidly and in such a way that it is adequately protected against damage.
- If the temperature at the point of entry is higher than $+70^{\circ}\text{C}$, adequately temperature-resistant connecting leads shall be used.

Statements of Conformity without signature and seal are invalid.
Extracts or changes shall require the prior approval of the Physikalisch-Technische Bundesanstalt.
Physikalisch-Technische Bundesanstalt Bundesallee 100 D-38116 Braunschweig **Photo-e 134_2.doc**

The user shall be informed of these Notes in a suitable manner.

Ambient temperature

The range of use of the Model 6134-2... P/I Converter extends in temperatures class T6 to ambient temperatures from -40°C to $+60^{\circ}\text{C}$, temperature class T5 to ambient temperatures from -40°C to $+70^{\circ}\text{C}$, temperatures class T4 to ambient temperatures from -40°C to $+80^{\circ}\text{C}$.

Pneumatic working medium

the user of the apparatus shall ensure that the working medium cannot form an explosive atmosphere, i. e. only gases may be used that are free from substances the existence of which could lead to an explosive atmosphere (non-combustible gases and no oxygen or gases enriched with oxygen).

(18) **Special health and safety requirements**

Satisfied by compliance with the standards specified above.

Zertifizierungsstelle Explosionsschutz
By order

Braunschweig, 6 November 2003

(Signature) (seal)

Dr.-Ing. H. Wehinger
Direktor und Professor

Statements of Conformity without signature and seal are invalid.
This Statement of Conformity may be reproduced only in its entirety, without any changes.
Extracts or changes shall require the prior approval of the Physikalisch-Technische Bundesanstalt.
Physikalisch-Technische Bundesanstalt Bundesallee 100 D-38116 Braunschweig **Photo-e 134_2.doc**

EC TYPE EXAMINATION CERTIFICATE

(1) Equipment and Protective Systems Intended for Use in Potentially Explosive Atmospheres – **Directive 94/9/EC**

(2) EC Type Examination Certificate Number

PTB 04 ATEX 2023

(3) Equipment: Model 6134... p/I Converter

(4) Manufacturer: SAMSON AG Mess- und Regellechnik

(5) Address: Weismüllerstr. 3, 60314 Frankfurt am Main, Germany

(6) The equipment and any acceptable variation thereof are specified in the schedule to this certificate.

(7) The Physikalisch-Technische Bundesanstalt, notified body number 0102 according to the EU Directive 94/9/EC, has issued this certificate. This equipment has been found to comply with the essential health and safety requirements relating to the design and construction of equipment and protective systems intended for use in potentially explosive atmospheres specified in Annex II to the Directive.

The examination and test results are recorded in confidential report.

PTB Ex. 04-23466

(8) The essential health and safety requirements are satisfied by compliance with

EN 50014:1997 + A1 + A2

EN 50020:2002

(9) If the sign "X" is placed after the certificate number, it indicates that the equipment is subject to special conditions for safe use as specified in the schedule to this certificate.

(10) According to the Directive 94/9/EC, this EC Type Examination Certificate relates only to the design and construction of the specified equipment. If applicable, further requirements of this Directive apply to the Manufacture and apply to the Manufacture and supply of this equipment.

Statements of Conformity without signature and seal are invalid.
This Statement of Conformity may be reproduced only in its entirety, without any abridgement or change, and requires the prior approval of the Physikalisch-Technische Bundesanstalt.
Physikalisch-technische Bundesanstalt Bundesallee 100 D-38116 Braunschweig **PTB 04-0134-1.deu**

(12) The marking of the equipment shall include the following:

 II 2G Ex Ia IIC T6

Zertifizierungsstelle Explosionsschutz
By order

Braunschweig, 19 March 2004

(Signature) (Seal)
Dr.-Ing. U. Jahnsmeyer
Regierungsdirektor

Statements of Conformity without signature and seal are invalid.
This Statement of Conformity may be reproduced only in its entirety, without any abridgement or change, and requires the prior approval of the Physikalisch-Technische Bundesanstalt.
Physikalisch-technische Bundesanstalt Bundesallee 100 D-38116 Braunschweig **PTB 04-0134-1.deu**

Physikalisch-Technische Bundesanstalt
Braunschweig und Berlin

PTB

(13) **S c h e d u l e**

(14) **EC Type Examination Certificate No. PTB 04 ATEX 2023**

(15) **Description of Equipment**

The Model 6134-1 p/I Converter serves for converting a standard pressure signal into a pressure-proportional current signal of 4 to 20 mA in the signal circuit.

The Model 6134-1 p/I Converter is a passive two-terminal network, which may be connected to any certified intrinsically safe circuit, provided the permissible values of UI, II and PI are not exceeded.

The media used are one-combustible gases and vapours.

The equipment is intended for use inside and outside of hazardous locations.

The correlation between temperature classification and permissible ambient temperature ranges is shown in the table below:

| Temperature class | Permissible ambient temperature range |
|-------------------|---------------------------------------|
| T6 | -40 °C ... 60 °C |
| T5 | -40 °C ... 70 °C |
| T4 | -40 °C ... 80 °C |

Electrical data

Signal circuit

Type of protection; Intrinsic safety
EEx ia IIC only for connection to a certified intrinsically safe circuit

Maximum values:

- UI = 28 V
- II = 115 mA
- PI = 1 W
- LI = negligible
- CI = 5.3 nF

Statements of Conformity without signature and seal are invalid.
This Statement of Conformity may be reproduced only in its entirety without any change.
Extracts or changes shall require the prior approval of the Physikalisch-Technische Bundesanstalt.
Physikalisch-Technische Bundesanstalt Bundesallee 100 D-38116 Braunschweig **PTB02-A134-1.doc**

Physikalisch-Technische Bundesanstalt
Braunschweig und Berlin

PTB

(16) Test report **PTB Ex 04-23466**

(17) Special conditions for safe use

None

(18) **Special health and safety requirements**

Are satisfied by compliance with the standards specified above.

Braunschweig, 19 March 2004

Zertifizierungsstelle Explosionsschutz

By order

(Signature) (seal)
Dr.-Ing. Johannesmeyer
Regierungsabteilung

Statements of Conformity without signature and seal are invalid.
This Statement of Conformity may be reproduced only in its entirety without any change.
Extracts or changes shall require the prior approval of the Physikalisch-Technische Bundesanstalt.
Physikalisch-Technische Bundesanstalt Bundesallee 100 D-38116 Braunschweig **PTB02-A134-1.doc**



SAMSON AG · MESS- UND REGELTECHNIK
Weismüllerstraße 3 · 60314 Frankfurt am Main · Germany
Phone: +49 69 4009-0 · Fax: +49 69 4009-1507
Internet: <http://www.samson.de>

EB 6134 EN

2008-10