

Globe Valve Type 3241



Fig. 1 · Type 3241 Globe Valve

Mounting and Operating Instructions

EB 8015-1 EN

Edition June 2004



Contents	Page
1	Design and principle of operation 4
2	Assembling valve and actuator 6
2.1	Travel adjustment. 6
3	Installation 6
3.1	Mounting position 6
3.2	Strainer, bypass 6
3.3	Test connection 6
4	Operation 7
5	Maintenance – Replacing parts. 7
5.1	Standard valve version 8
5.1.1	Stuffing box packing 8
5.1.2	Seat and/or plug. 9
5.2	Valve with insulating section or metal bellows seal 10
5.2.1	Stuffing box packing 10
5.2.2	Plug 10
5.2.3	Seat 12
5.2.4	Metal bellows. 12
5.2.5	Reassembly 13
5.3	Replacing the collar or seal 14
6	Material identifying marks 16
7	Description of nameplates. 17
8	Customer inquiries 18

Note!

*Non-electrical control valves which do not have a valve body lined with an insulating material coating do not have their own potential ignition source according to the risk assessment in the rare incident of an operating fault, corresponding to EN 13463-1: 2001 paragraph 5.2, and therefore do **not** fall within the scope of the European Directive 94/9/EC.*

Refer to paragraph 6.3 of EN 60079-14:1977 VDE 0165 Part 1 concerning connection to equipotential bonding system.



General safety instructions

- ▶ The control valve may only be mounted, started up or serviced by fully trained and qualified personnel, observing the accepted industry codes and practices. Make sure employees or third persons are not exposed to any danger. All safety instructions and warnings in these mounting and operating instructions, particularly those concerning assembly, start-up and maintenance, must be observed.
- ▶ The control valves fulfill the requirements of the European Pressure Equipment Directive 97/23/EC. Valves with a CE marking have a declaration of conformity that includes information about the applied conformity assessment procedure. The declaration of conformity is available on request.
- ▶ For appropriate operation, make sure that the control valve is only used in areas where the operating pressure and temperatures do not exceed the operating values which are based on the valve sizing data submitted in the order. The manufacturer does not assume any responsibility for damage caused by external forces or any other external influence! Any hazards which could be caused in the control valve by the process medium, operating pressure, signal pressure or by moving parts are to be prevented by means of the appropriate measures.
- ▶ Proper shipping and appropriate storage of the control valve are assumed.

Caution!

- ▶ For installation and maintenance work on the valve, make sure the relevant section of the pipeline is depressurized and, depending on the process medium, drained as well. If necessary, allow the control valve to cool down or warm up to reach ambient temperature prior to starting any work on the valve.
- ▶ Prior to performing any work on the valve, make sure the lines for the electrical or supply air as well as the control signal are disconnected or blocked to prevent any hazards that could be caused by moving parts.

1 Design and principle of operation

The single-seated Type 3241 Globe Valve can be combined with different actuators to form either a pneumatic control valve or an

electric control valve. Additionally, the valve can be fitted with a hand-operated actuator. Thanks to the modular design, the actuators can be exchanged, and the standard version of the valve can be supplemented to form a version with insulating section or metal bellows seal.

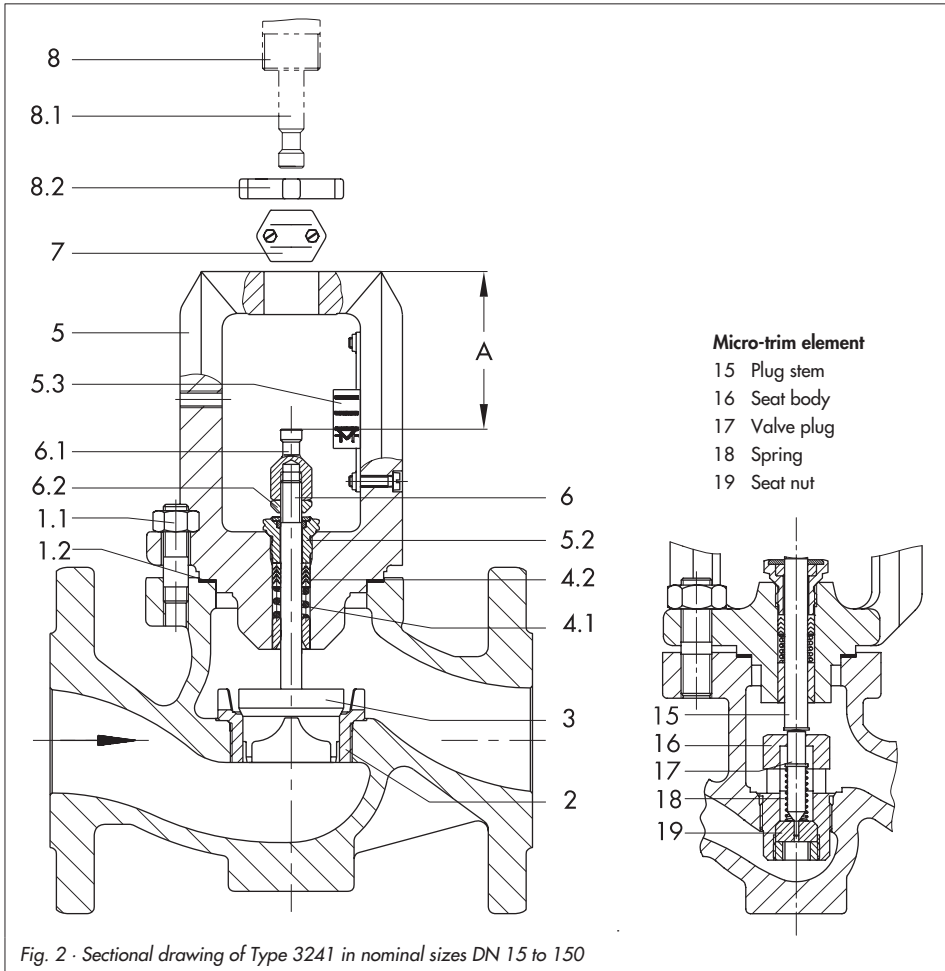

In the **micro-flow valve** version, a micro-trim element is installed in the valve body instead of the usual seat-plug assembly. The process medium flows through the valve in the direction indicated by the arrow. The position of the plug (3) determines the flow through the valve seat (2). The position of

the plug (3) is changed by the signal pressure acting on the diaphragm of the actuator (bench range). Plug (3) and actuator stem (8.1) are connected via the stem connector (7) and sealed by the spring-loaded ring packing (4.2).

Travel adjustment (with a valve closed)	
DN	Dimension A
15 to 80	75 ± 0.1
100 to 150	90 ± 0.1
200 and 250	165 (225)

- 1. Valve body
- 1.1 Nuts
- 1.2 Gasket
- 2 Seat
- 3 Plug
- 4.1 Spring
- 4.2 Packing
- 5 Valve bonnet
- 5.2 Threaded bushing
- 5.3 Travel indicator scale
- 6 Plug stem
- 6.1 Stem connector nut
- 6.2 Lock nut
- 6.3 Yoke (DN 200 and 250)
- 7 Stem connector
- 8 Actuator
- 8.1 Actuator stem
- 8.2 Nut

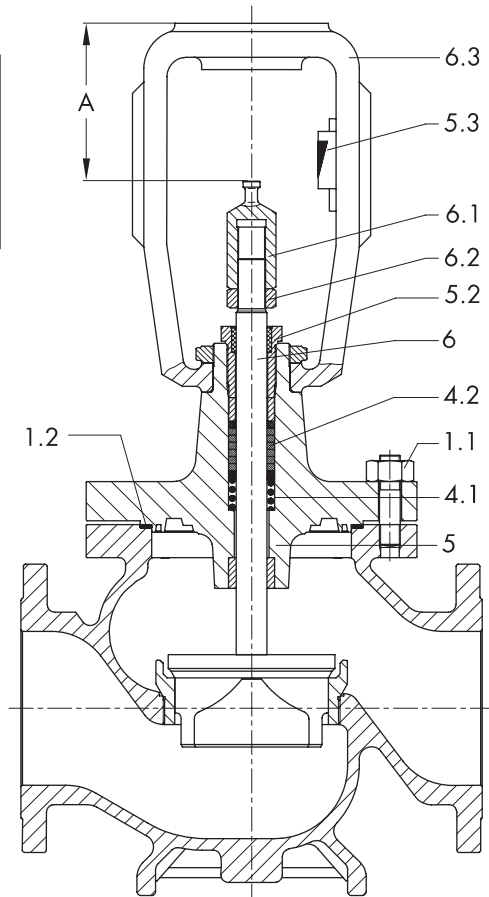

Fig. 3 · Sectional drawing of Type 3241 in nominal sizes DN 200 and 250

2 Assembling valve and actuator

Note!

Refer to the Mounting and Operating Instructions of the corresponding actuator for assembly.

2.1 Travel adjustment

When valve and actuator are shipped separately, dimension A, which extends from the top of the stem connector nut (6.1) to the top of the valve bonnet (yoke), is adjusted according to the table in Fig. 3.

Check this dimension on assembly and, if necessary, readjust it by turning the stem connector nut.

3 Installation

3.1 Mounting position

The valve can be mounted in any desired position. However, vertical installation with the actuator pointing upwards is preferable for valves in nominal size DN 100 or larger. Otherwise, difficulties during maintenance work can occur.

For valves with insulating section or metal bellows seal, or for actuators weighing more than 50 kg, mount a suitable support or suspension for the actuator.



Note!

The valve must be installed with as little vibration as possible and free of stress.
Flush the pipeline thoroughly before installation.

Note!

Do not insulate control valves which must conform to **NACE MR 0175**.

3.2 Strainer, bypass

We recommend you to install a SAMSON Type 2 Strainer upstream of the valve body. We also recommend to install a shut-off valve both upstream of the strainer and downstream of the valve, as well as a bypass, so that you do not need to shut down the plant for maintenance.

3.3 Test connection

If there is a test connection (G 1/8) at the upper flange of a valve version with metal bellows seal (Fig. 6), you can check the tightness of the bellows there. Particularly for liquids and vapors, we recommend you to install a suitable leak indicator at the test connection, such as a contact pressure gauge, an outlet into an open vessel or an inspection window.

4 Operation

As the operating instructions only apply when the valve is used in conjunction with an actuator, refer to the associated Mounting and Operating Instructions of the actuator mounted on the valve.

5 Maintenance – Replacing parts

The control valve is subject to natural wear, especially at the seat, plug and packing. Depending on the application, the valve needs to be checked regularly to prevent against possible failures.

If leakage occurs, this could be caused by a damaged packing or a defective metal bellows.

If the valve does not seal properly, the tight shut-off may be impeded by dirt or other impurities caught between the seat and plug, or by damaged seat joints.

Remove the parts, clean them thoroughly and replace them, if necessary.

Note!

Suitable seat and special tools as well as the appropriate tightening torques required for installation are listed in EB 029 EN (formerly WA 029 EN) which can be viewed on the Internet at http://www.samson.de/pdf_en/e00290en.pdf.



Note!

Before servicing or disassembling the control valve, depressurize the concerned section of the plant and drain it, if necessary, depending on the medium used.

Wait until the medium has cooled down, if necessary.

As valves are not free of cavities, there might still be residual medium in the valve.

This applies, in particular, for valve versions with insulating section and metal bellows seal.

We recommend removing the valve from the pipeline.

Caution!

On performing any work on the valve body, first shut off the electric or pneumatic auxiliary energy supply and block it as well as interrupt the control signals to prevent any hazards caused by moving parts.

Remove the actuator from the valve before carrying out any work on the valve body.

5.1 Standard valve version

5.1.1 Stuffing box packing

1. Remove the body nuts (1.1) as well as the valve bonnet (5) together with the plug stem and plug from the body.
2. Unscrew the stem connector nut and lock nut (6.1 and 6.2) from the plug stem.
3. Unscrew the threaded bushing (5.2) out of the stuffing box. Pull the plug stem together with the plug out of the valve bonnet.
4. Pull all stuffing box parts out of the packing chamber using a suitable tool. Replace damaged parts. Clean packing chamber thoroughly.
5. Remove the gasket (1.2) and carefully clean sealing surfaces in the valve body and on the bonnet.
6. Apply lubricant (order no. 8150-0111) to all the packing parts and the plug stem (6).
7. Slide the plug stem with plug into the valve bonnet.

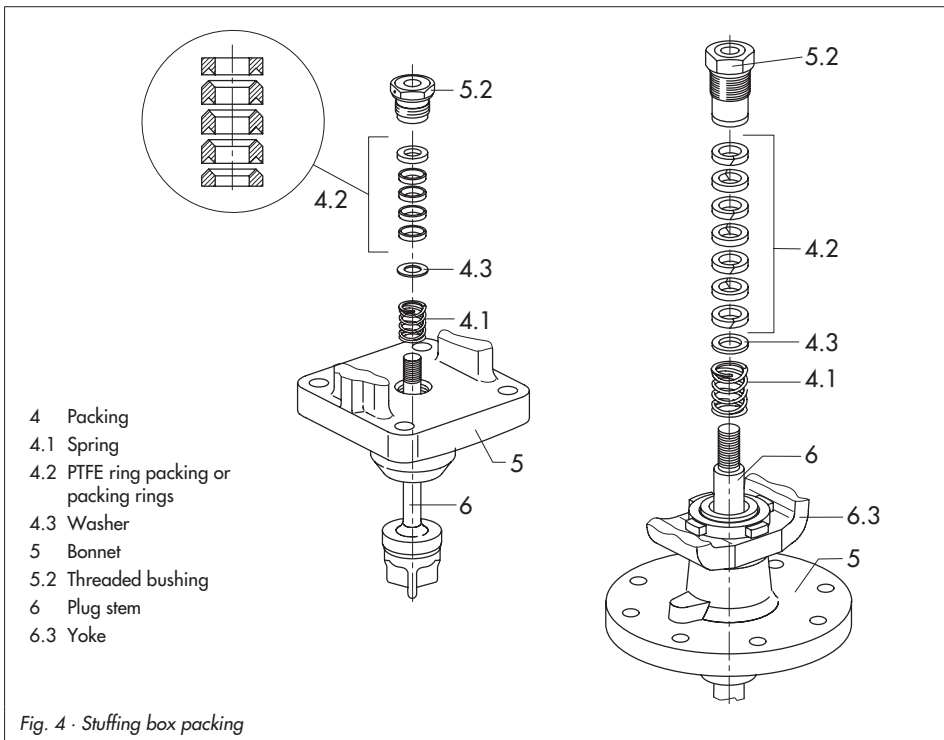

8. Insert a new gasket (1.2) into the body. Carefully place the valve bonnet onto the valve body and secure with nuts (1.1).
9. Carefully slide the stuffing box parts over the plug stem into the packing chamber. Make sure to keep the proper order.
Screw in the threaded bushing (5.2) and tighten.
10. Loosely screw the lock nut (6.2) and stem connector nut (6.1) onto the plug stem.
11. Adjust the travel as described in section 2.1 and mount the actuator.

5.1.2 Seat and/or plug

We recommend you to also replace the packing (4.2) when exchanging the seat and plug.

To exchange the packing, proceed as described in section 5.1.1.

Plug:

- ▶ Remove the old plug and replace it with a new plug with plug stem. It is possible to use the old plug again, provided it has been reworked properly. Apply lubricant (order no. 8150-0111) to the plug stem before installation.

Reworking the plug

- ▶ Slight damage at the sealing edges of the plug can be eliminated by re-turning it on a lathe. Soft-sealing plugs can only be reworked until dimension x (Fig. 5) is reached, and if the seat bore exceeds 12 mm. For seat bores of 63 mm and

larger, the entire sealing ring can be exchanged, if necessary (the plug parts are screwed together).

Seat:

- ▶ Unscrew the seat (2) using the appropriate seat wrench (see EB 029 EN). Apply lubricant (order no. 8150-0119) to the thread and sealing cone of the new seat (or possibly the old seat when it has been reworked or thoroughly cleaned) and screw it in.

Micro-flow valve version

In this version, the complete micro-trim element (Fig. 2) can be unscrewed from the valve body using a socket wrench (width across flats 27) and disassembled for cleaning.

If any parts are damaged, exchange the entire micro-trim element.

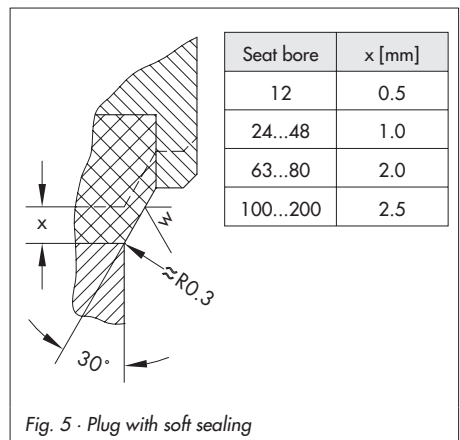

5.2 Valve with insulating section or metal bellows seal

5.2.1 Stuffing box packing

1. Remove the stem connector nut and lock nut (6.1 and 6.2) from the plug stem extension (6.3). Unscrew the threaded bushing (5.2) out of the stuffing box.
2. Remove nuts (5.4) and carefully lift the bonnet (5) over the plug stem extension.
3. Pull all packing parts out of the packing chamber using a suitable tool. Replace damaged parts. Clean packing chamber thoroughly.
4. Remove the gasket (5.5) in the intermediate piece (12) and carefully clean the sealing faces.
5. Apply lubricant (order no. 8150-0111) to all the packing parts and the plug stem (6).
6. Insert a new gasket (5.5) in the intermediate piece. Carefully place the bonnet over the plug stem extension onto the bonnet and secure with nuts (5.4).
7. Carefully slide the stuffing box parts over the plug stem extension into the packing chamber. Make sure to keep the proper order. Screw in the threaded bushing (5.2) and tighten.
8. Loosely screw the lock nut (6.2) and stem connector nut (6.1) onto the plug stem.
9. Adjust the travel as described in section 2.1 and mount the actuator.

5.2.2 Plug

When exchanging the plug, check the packing (4.2) or, preferably, replace it as described in section 5.1.

DN 15 to DN 150: To unscrew the plug (6) from the plug stem extension (6.3), screw two nuts onto the protruding thread of the extension to hold the plug stem extension in place.



Caution!

To prevent damage to the version with the bellows seal (no bellows in the version with insulating section), make sure no torque is transmitted to the bellows, which is connected to the intermediate piece. We recommend you to use a clamping tool (see EB 029 EN).

1. Remove the nuts (1.1).
2. Remove the intermediate piece (12) together with the plug stem extension, plug stem and plug from the valve body.
3. Remove gasket (1.2) and carefully clean the sealing faces in the valve body and on the intermediate piece.
4. Use an appropriate wrench to hold the nuts stationary, which are screwed onto the plug stem extension. Clamp the plug stem using a suitable tool and screw it out of the plug stem extension.
Caution! Do not twist the plug stem extension with the welded-on bellows!
5. Apply lubricant (order no. 8150-0111) to the end of the plug stem (6) of the new or old, reworked plug (3).

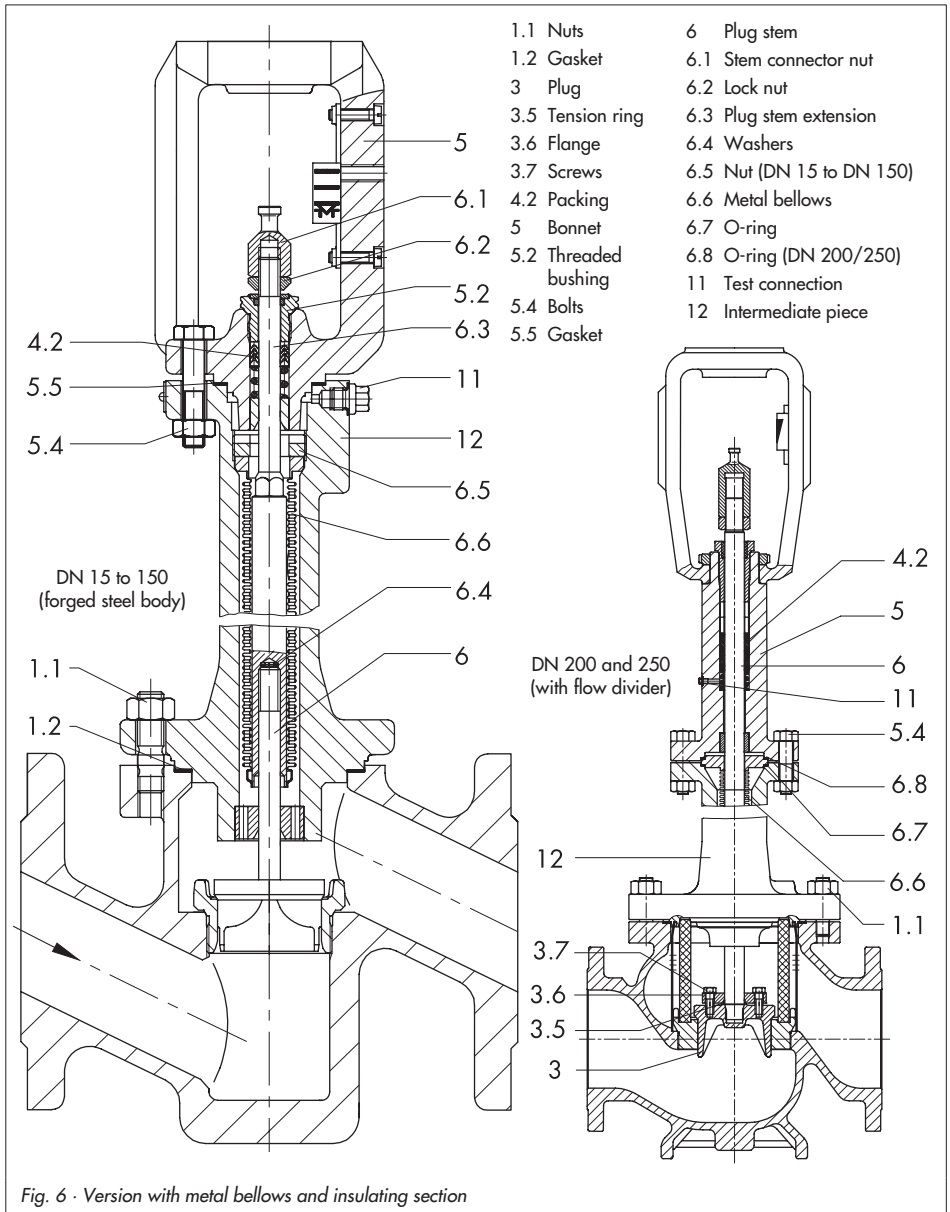

Check whether the two washers (6.4) are still in the plug stem extension (6.3). Screw the plug stem firmly into the plug stem extension (6.3); tightening torque is 50 Nm for \varnothing 10 mm and 80 Nm for \varnothing 16 mm.

- ▶ To complete assembly, refer to section 5.2.5.

DN 200 and DN 250:

1. Remove the nuts (1.1).
 2. Remove the intermediate piece (12) together with the plug stem extension, plug stem and plug from the valve body.
 3. Remove gasket (1.2) and carefully clean the sealing faces in the valve body and on the intermediate piece.
 4. Remove the hexagon head screws (3.7), tension ring (3.5) and flange (3.6).
 5. Unscrew the plug from the plug stem. To do so, use a suitable tool to hold the plug stem in place, so that the metal bellows, which is welded onto the plug stem, cannot be twisted.
 6. Screw a new plug with tension ring and flange to the plug stem.
- ▶ To complete assembly, refer to section 5.2.5.

In the version with insulating section, there are no parts 3.5, 3.6 and 3.7. Plug (3) and plug stem(6) form one piece.

5.2.3 Seat

Replace the seat (2) as described in section 5.1.2.

5.2.4 Metal bellows

DN 15 to DN 150:

1. Unscrew the plug (3) together with the plug stem (6) from the plug stem extension (6.3) as described for replacing the seat in section 5.2.2.
2. Unscrew the nut (6.5) using a SAMSON socket wrench (see EB 029 EN).
3. Pull the plug stem extension with the welded-on metal bellows (6.6) out of the intermediate section (12).
4. Clean the sealing faces on the intermediate piece.
5. Insert a new plug into the intermediate piece and screw down the nut (6.5).



Caution!

Do not twist the metal bellows!

6. Check whether both washers (6.4) are still in the plug stem extension (6.3). Apply lubricant (order no. 8150-0111) to the thread of the plug stem and firmly screw the plug stem into the plug stem extension (6.3) with a tightening torque of 50 Nm for a plug stem diameter of 10 mm and 80 Nm for a diameter of 16 mm.

DN 200 and DN 250:

1. Unscrew the plug (3) from the plug stem as described in section 5.2.2. Pull the plug stem (6) together with the metal bellows (6.6) upwards, out of the intermediate piece (12).

2. Replace the O-ring (6.7) and insert a new plug stem with metal bellows (6.6).
3. Screw on the plug and secure with the tension ring (3.5), flange (3.6) and screws (3.7).

5.2.5 Reassembly

1. Insert a new gasket (1.2) into the valve body. Place the intermediate piece (12) onto the valve body (1) and secure with nuts (1.1).
2. Insert a new gasket (5.5) into the intermediate piece. Place the valve bonnet (5) onto the intermediate piece and secure with nuts and bolts (5.4).
Observe the tightening torques specified in EB 029 EN.
3. Tighten the threaded bushing (5.2).
4. Loosely screw the lock nut (6.2) and stem connector nut (6.1) onto the plug stem extension (6.3) or plug stem.
5. Adjust the travel as described in section 2.1 and mount the actuator.

5.3 Replacing the collar or seal

For version with pressure-balanced plug:

1. Unscrew the stem connector nut and lock nut (6.1 and 6.2) from the plug stem.
2. Remove the body nuts (1.1) and carefully lift off the valve bonnet (5) with plug stem (6).
3. Screw the threaded bushing (5.2) out of the stuffing box. Pull plug stem and plug (3) out of the bonnet.
4. Remove gasket (1.2) and carefully clean the sealing faces in the valve body and on the bonnet.

DN 40:

5. Pull the packing (4.2), washer (4.3) and spring (4.1) out of the packing chamber using an appropriate tool. Replace damaged parts.
6. Push out the bushing (3.2) and replace the collar (3.1).
Clean the packing chamber thoroughly.
7. Apply lubricant (order no. 8150-0111) to the bushing (3.2) and push it in again.
8. Also apply lubricant to the packing parts, plug stem (6) and the contact faces of the collar (3.1).
9. Insert the plug stem and plug into the valve bonnet.

Completion of reassembly:

10. Insert a new gasket (1.2) into the valve body. Carefully place the valve bonnet on the valve body and secure with nuts (1.1). Observe the tightening torques specified in EB 029 EN.
11. Slide the stuffing box parts over the plug stem into the packing chamber. Make sure to keep the proper order.
12. Screw in the threaded bushing (5.2) and tighten.
13. Loosely screw the lock nut (6.2) and stem connector nut (6.1) onto the plug stem.
14. Adjust the travel as described in section 2.1 and mount the actuator.

DN 50 to DN 150:

5. Remove screw (3.4) with its locking device and washer (3.3). Replace collar (3.1) with a new one.
 6. Insert washer (3.3). Thread down the screw (3.4) with its locking device.
 7. Apply lubricant (order no. 8150-0111) to the packing parts, plug stem (6) and contact faces of collar (3.1).
 8. Insert the plug stem and plug into the valve bonnet.
- Complete reassembly as described for DN 40, steps 10 to 14.

DN 200 and DN 250:

5. Remove the screw (3.4) with its locking device.
6. Lift off the ring (3.3) and replace collar or seal (3.1).
7. Insert ring (3.3).
Thread down screw (3.4) and its locking device.

8. Apply lubricant (order no. 8150-0111) to the packing parts, plug stem (6) and contact faces of the collar (3.1).
9. Insert the plug stem and plug into the valve bonnet.

► Complete reassembly as described for DN 40, steps 10 to 14.

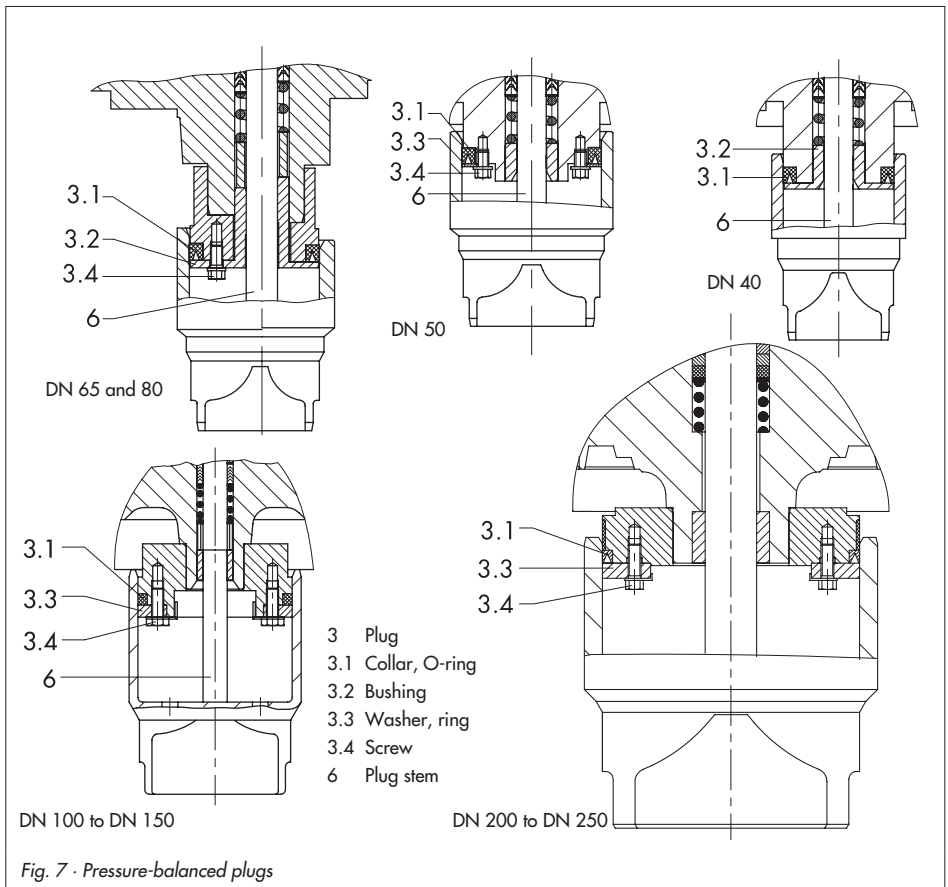

Fig. 7 · Pressure-balanced plugs

6 Material identifying marks

Guide bushing, seat and plug have the following identifying marks:

Guide bushing (groove on plane face)

- ▶ No groove: 1.4305
- ▶ Sharp recessed groove: 1.4571
- ▶ Flat recessed groove: Hastelloy

Seat

The material number according to DIN is either stamped or engraved on the seat.

- ▶ Stellite seats are marked by a stamped-on "st".

Plug

Groove below the plug stem thread:

- ▶ No groove: 1.4006
- ▶ Sharp recessed groove: 1.4571
- ▶ Two sharp recessed grooves: 1.4301
- ▶ Flat recessed groove: Hastelloy
- ▶ When other materials are used, either the material number or its designation is engraved on the plug.

The **Kvs coefficient and characteristic** are engraved on the plug.

- ▶ Stellite plugs are marked by an engraved "st".

7 Description of nameplates

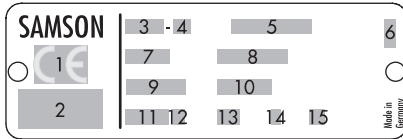

- 1 CE marking or "Art. 3, Abs.3" (see article 3, § 3 of PED), where applicable
- 2 Identification no. of notified body, fluid group and category, where applicable
- 3 Type designation
- 4 Modification index of valve
- 5 Material
- 6 Year of manufacture
- 7 Nominal size: DIN: DN, ANSI: Size
- 8 Permissible excess pressure at room temperature
DIN: PN, ANSI: CL
- 9 Order number with modification index
- 10 Position of item in order
- 11 Flow coefficient:
DIN: K_{vs} , ANSI: C_v
- 12 Characteristic:
% equal percentage, Lin linear,
DIN: **A/Z** quick opening, ANSI: **O/C**
- 13 Sealing:
ME metal, **ST** stellited, **Ni** nickel-plated
PT soft sealing with PTFE,
PK soft sealing with PEEK
- 14 Pressure-balanced: DIN: **D**, ANSI: **B**
- 15 **I** or **III** flow divider

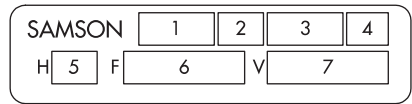

- 1 Type designation
- 2 Modification index
- 3 Effective diaphragm area
- 4 Fail-safe action:
FA Actuator stem extends
FE Actuator stem retracts
- 5 Travel
- 6 Bench range (spring range)
- 7 Bench range with pretensioned springs

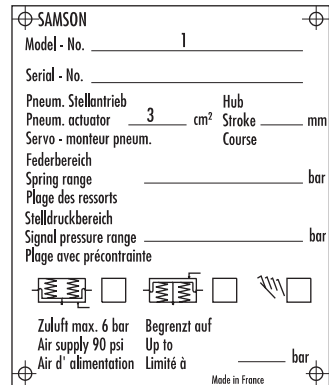

Fig. 8 · Valve nameplate (left) and actuator nameplates (right)

8 Customer inquiries

If you encounter any problems, please submit the following details:

- ▶ Order number
- ▶ Type, product number, nominal size and version of the valve
- ▶ Pressure and temperature of the process medium
- ▶ Flow rate in m³/h
- ▶ Has a strainer been installed?
- ▶ Installation drawing

Dimensions and weights of the valve versions can be found in Data Sheet T 8015 EN.



SAMSON AG · MESS- UND REGELTECHNIK
Weismüllerstraße 3 · 60314 Frankfurt am Main · Germany
Phone: +49 69 4009-0 · Fax: +49 69 4009-1507
Internet: <http://www.samson.de>

EB 8015-1 EN

S/Z 2006-02