

Pneumatic Control Valves Type 3244-1 and Type 3244-7



Fig. 1 · Type 3244 -1 (left) and Type 3244-7 (right)

Mounting and Operating Instructions

EB 8026 EN

Edition July 2007



Contents	Page
1	Design and principle of operation 4
2	Assembling valve and actuator 6
2.1	Assembly and adjustment 6
2.2	Option to pretension the springs for actuator version "Actuator stem extends". 7
3	Installation 8
3.1	Mounting position 8
3.2	Arrangement of the control valve 8
3.3	Signal pressure line. 8
3.4	Strainer, bypass 8
3.5	Test connection 8
4	Operation 10
5	Maintenance – Replacing parts 10
5.1	Standard valve version 11
5.1.1	Stuffing box packing 11
5.1.2	Seat and/or plug 11
5.2	Valve with insulating section or metal bellows seal 12
5.2.1	Stuffing box packing 12
5.2.2	Seat and plug. 14
5.2.3	Metal bellows 15
5.2.4	Reassembly 15
6	Material identifying marks 16
7	Description of nameplates. 17
8	Customer inquiries 17

These Mounting and Operating Instructions apply also to **Type 3246 Globe Valve** (Class 150 and 300) in conjunction with Data Sheet T 8046-3 EN.

Note!

*Non-electrical actuators and control valves do not have their own potential ignition source according to the risk assessment in the rare incident of an operating fault, corresponding to EN 13463-1: 2001 paragraph 5.2, and therefore do **not** fall within the scope of the European Directive 94/9/EC.*

Refer to paragraph 6.3 of EN 60079-14:1977 VDE 0165 Part 1 concerning connection to equipotential bonding system.



General safety instructions

- ▶ The control valve may only be mounted, started up or serviced by fully trained and qualified personnel, observing the accepted industry codes and practices. Make sure employees or third persons are not exposed to any danger. All safety instructions and warnings in these mounting and operating instructions, particularly those concerning assembly, start-up and maintenance, must be observed.
- ▶ The control valves fulfill the requirements of the European Pressure Equipment Directive 97/23/EC. Valves with a CE marking have a declaration of conformity that includes information about the applied conformity assessment procedure.
The corresponding declaration of conformity can be viewed and downloaded on the Internet at <http://www.samson.de>.
- ▶ For appropriate operation, make sure that the control valve is only used in areas where the operating pressure and temperatures do not exceed the operating values which are based on the valve sizing data submitted in the order. The manufacturer does not assume any responsibility for damage caused by external forces or any other external influence! Any hazards which could be caused in the control valve by the process medium, operating pressure, signal pressure or by moving parts are to be prevented by means of the appropriate measures.
- ▶ Proper shipping and appropriate storage of the control valve are assumed.

Caution!

- ▶ For installation and maintenance work on the valve, make sure the relevant section of the pipeline is depressurized and, depending on the process medium, drained as well. If necessary, allow the control valve to cool down or warm up to reach ambient temperature prior to starting any work on the valve.
- ▶ Prior to performing any work on the valve, make sure the supply air and control signal are disconnected or blocked to prevent any hazards that could be caused by moving parts.
- ▶ Special care is needed with pneumatic control valves when the actuator springs are pretensioned. These actuators are labeled correspondingly and can also be identified by three long bolts protruding from the bottom of the actuator. Prior to starting any work on the control valve, relieve the compression from the pretensioned springs.

1 Design and principle of operation

The Type 3244-1 and Type 3244-7 Pneumatic Control Valves consist of a Type 3244 Three-way Valve and either a Type 3271 or a Type 3277 Pneumatic Actuator.

Thanks to the modular design, the actuators can be exchanged, and the standard version of the valve can be supplemented to form a version with insulating section or metal bellows seal.

Depending on the plug arrangement, the three-way valve operates either as mixing or flow-diverting valve (in DN 15 to 25, the plugs are identical).

In mixing valves, the media to be mixed enter through ports **A** and **B**. The combined flow leaves at port **AB**.

In diverting valves, the medium enters through port **AB** and the diverted flows exit at ports **A** and **B**.

The flow rate from **A** or **B** to **AB** or vice versa is determined by the cross-sectional area released between the seat (2.1, 2.2) and the plug (3), and thus by the position of the plug stem (6).

The plug (3) is moved by the changing signal pressure acting on the diaphragm of the actuator. The plug stem (6) and the actuator stem (8.1) are connected over the stem connector (7); they are sealed by a spring-loaded PTFE ring packing (4.2).

Fail-safe position

Depending on the arrangement of the compression springs in the actuator, the control valve has two different fail-safe positions:

Actuator stem extends

When the pressure is relieved or the supply air fails, the springs cause port **B** (mixing valves) or port **A** (diverting valves) to close. Ports **B** or **A** are opened against the force of the springs when the signal pressure increases.

Actuator stem retracts

When the diaphragm is relieved of pressure or when the supply air fails, the springs cause port **B** (mixing valves) or port **A** (diverting valves) to open. Ports **B** or **A** are closed against the force of the springs when the signal pressure increases.

- 1.1 Nuts
- 1.2 Gasket
- 2.1 Top seat ring
- 2.2 Bottom seat ring
- 3 Plug
- 3.1 Plug part
- 3.2 Screws
- 4.1 Spring
- 4.2 Packing
- 5 Valve bonnet
- 5.2 Threaded bushing
- 5.3 Travel indicator scale
- 6 Plug stem
- 6.1 Stem connector nut
- 6.2 Lock nut
- 7 Stem connector
- 8 Actuator
- 8.1 Actuator stem
- 8.2 Nut

Type 3271 Actuator

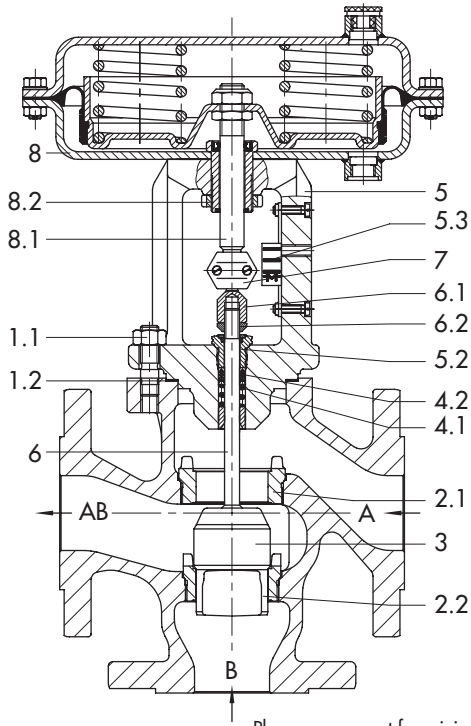

Plug arrangement for mixing service
in DN 15 to DN 25 also for flow-diverting service

Type 3277 Actuator

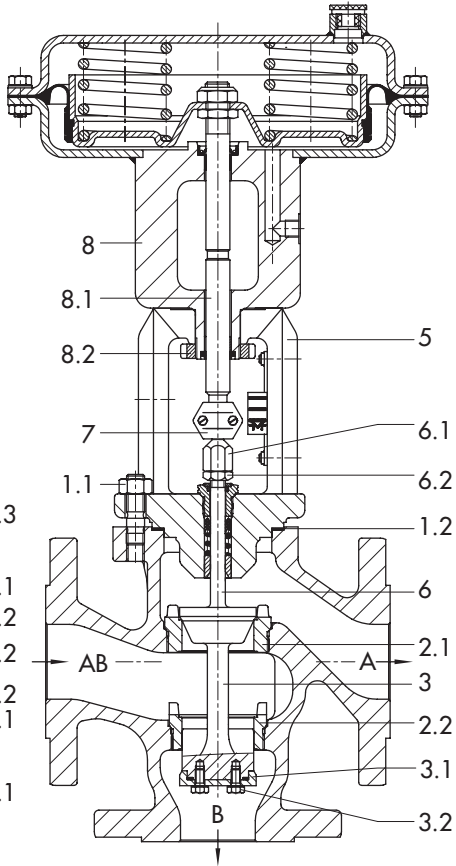

Plug arrangement for flow-diverting service
DN 15 to DN 25

Fig. 2 - Sectional drawings

2 Assembling valve and actuator

Instead of the simple pneumatic actuator, it is also possible to attach an actuator with additional handwheel or an electric actuator.

A pneumatic actuator (with or without handwheel) can be replaced by a pneumatic actuator in a different size.

If the travel range of the actuator exceeds that of the valve in the valve-actuator configuration, the manufacturer will adjust the spring assembly of the actuator such that the travels match.

2.1 Assembly and adjustment

If the valve and actuator have not already been assembled by the manufacturer, or if the original actuator is replaced by a different actuator size or model, proceed as follows to assemble the valve and actuator:

1. Loosen lock nut (6.2) and stem connector nut (6.1) from the valve.
Firmly press the plug with the plug stem into the seat ring. Turn stem connector nut and lock nut downward.
2. Remove clamps of the stem connector (7) and annular nut (8.2) from the actuator (8). Push annular nut over the plug stem.
3. Place actuator on the valve bonnet (5) and screw tight with the annular nut (8.2).
4. Read bench range (or range with pretensioned springs) and fail-safe action from the nameplate of the actuator (e.g. 0.2 to 1 bar and "Actuator stem extends").

The lower bench range value (0.2 bar) corresponds to the lower signal pressure range to be adjusted; the upper bench range value (1 bar) corresponds to the upper signal pressure range.

In Type 3271 Actuators, the fail-safe action "Actuator stem extends" is indicated by FA and "Actuator stem retracts" by FE on the nameplate. Type 3277 Actuators bear a corresponding symbol on the nameplate.

5. In actuator version "**Actuator stem extends**", apply a pressure corresponding to the lower bench range value (e.g. 0.2 bar) to the signal pressure connection on the bottom diaphragm case.
In actuator version "**Actuator stem retracts**", apply a pressure corresponding to the upper bench range value (e.g. 1 bar) to the connection on the top diaphragm case.
6. Turn stem connector nut (6.1) by hand until it touches the actuator stem (8.1). Turn it another quarter turn and secure position with the lock nut (6.2).
7. Attach clamps of the stem connector (7) and screw them tightly together. Align travel indicator scale (5.3) with the tip of the stem connector.

Note on disassembling the actuator:

When disassembling actuators with fail-safe action "Actuator stem extends" and particularly versions with pretensioned springs, apply a pressure slightly higher than the lower bench range value (see actuator nameplate) to the bottom signal pressure connection before unscrewing the annular nut (8.2).

2.2 Option to pretension the springs for actuator version "Actuator stem extends"

To achieve a greater thrust, the actuator springs can be pretensioned by up to 12.5 % (120 and 240 cm²) or by up to 25 % (350 cm² and larger) of their travel or their bench range span.

Example:

If, with a bench range of 0.2 to 1 bar, the springs are to be pretensioned by 0.1 bar, for example, the bench range is shifted by 0.1 bar, resulting in a new bench range of 0.3 to 1.1 bar (0.1 bar corresponds to a compression of 12.5 %).

When adjusting the valve, a signal pressure of 0.3 bar is to be set as the lower signal pressure range.

The new bench range of 0.3 to 1.1 bar must be marked on the nameplate as bench range with pretensioned springs.

**Caution!**

Actuators with springs that have already been pretensioned by the manufacturer without attachment to a valve are marked by an appropriate label.

In addition, such actuators can be identified by three bolts and nuts protruding from the bottom diaphragm case. These bolts and nuts allow you to evenly relieve the compression when disassembling the actuator.

3 Installation

3.1 Mounting position

The valve can be mounted in any desired position. However, vertical installation with the actuator pointing upwards is preferable for valves in DN 100 or larger. Otherwise, wear on the packing may increase.

For valves with insulating section or metal bellows seal, or for actuators weighing more than 50 kg, mount a suitable support or suspension for the actuator.

Note!

The valve must be installed with the least amount of vibrations possible and without any stress.

Piping design

To allow the control valve to work properly, the pipeline upstream and downstream of the valve should be straight and free of obstructions for a length of at least 6 times the pipe diameter (DN).

Contact SAMSON if this length cannot be met during installation.

Clean out the pipeline thoroughly prior to installing the valve.

3.2 Arrangement of the control valve

Arrange the control valve depending on the desired service as illustrated in Fig. 3.

The installation examples refer to the standard application using fail-safe action "Actuator stem extends" for heating service and "Actuator stem retracts" for cooling service.

When the fail-safe action is triggered, the

valve shuts off the heating or cooling media. The plug arrangement for either mixing or diverting service is marked on a plate on the valve body.

Valves in sizes DN 15 to 25 have an identical plug arrangement for both mixing and diverting service.

3.3 Signal pressure line

Connect the signal pressure line to the bottom diaphragm case for valves with actuator version "Actuator stem extends" and to the top diaphragm case for valves with actuator version "Actuator stem retracts".

In the Type 3277 Actuator, the bottom connection is located at the side of the yoke on the bottom diaphragm case.

3.4 Strainer, bypass

We recommend to install a SAMSON Type 2 Strainer upstream of the valve body. We also recommend to install a shut-off valve both upstream of the strainer and downstream of the valve, as well as a bypass, so that you do not need to shut down the plant for maintenance.

3.5 Test connection

If there is a test connection (G 1/8) at the upper flange of a valve version with metal bellows seal (Fig. 5), you can check the tightness of the bellows there.

Particularly for liquids and vapors, we recommend you to install a suitable leak indicator at the test connection, such as a contact pressure gauge, an outlet into an open vessel or an inspection window.

Mixing service

Temperature control $Q = \text{constant}$

Fail-safe action: FA = Actuator stem extends, FE = Actuator stem retracts
 In heating service with FA, the heating medium (flow) is shut off in fail-safe position.
 In cooling service with FE, cooling is continued when the fail-safe action is triggered.

Flow-diverting service

Flow rate control $Q = 0 \text{ to } 100 \%$

**Heating with mixing valve FA or cooling with mixing valve FE
 Installation in the flow pipe**

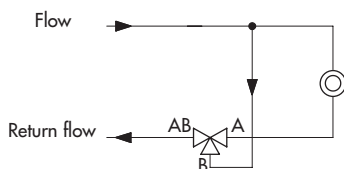
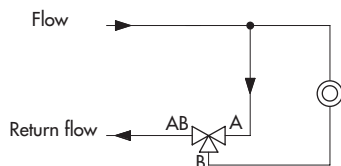
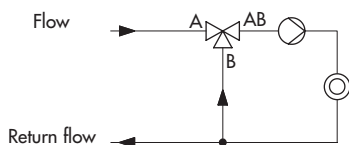
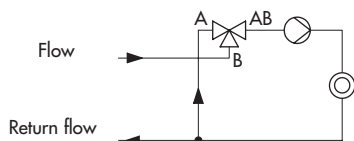

**Heating with diverting valve FA or cooling with diverting valve FE
 Installation in the return flow pipe**

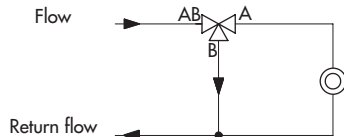
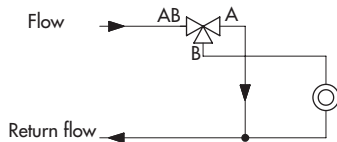
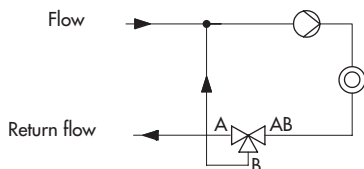
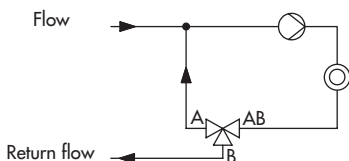

Fig. 3 · Typical installations

4 Operation

(e.g. reversing the direction of action, etc.)

For details, refer to the Mounting and Operating Instructions of the respective pneumatic actuator.

EB 8310 EN for Type 3271 and
EB 8311 EN for Type 3277.

5 Maintenance – Replacing parts

The control valve is subject to natural wear, especially at the seat, plug and packing. Depending on the application, the valve needs to be checked regularly to prevent against possible failures.

If leakage occurs, this could be caused by a damaged packing or a defective metal bellows.

If the valve does not seal properly, the tight shut-off may be impeded by dirt or other impurities caught between the seat and plug, or by damaged seating surfaces.

Remove the parts, clean them thoroughly and replace them, if necessary.

Note!

Suitable seat and special tools as well as the appropriate tightening torques required for installation are listed in EB 029 EN (formerly WA 029 EN), which can be viewed on the Internet at http://www.samon.de/pdf_en/e00290en.pdf.



Note!

Before servicing or disassembling the control valve, depressurize the concerned section of the plant and drain it, if necessary, depending on the medium used.

Wait until the medium has cooled down, if necessary.

As valves are not free of cavities, there might still be residual medium in the valve.

This applies, in particular, for valve versions with insulating section or metal bellows seal.

We recommend removing the valve from the pipeline.

Caution!

On performing any work on the valve body, first shut off the supply pressure, disconnect the supply pressure line and remove the actuator.

Disassembling the actuator:

1. Remove stem connector (7) and unscrew annular nut (8.2).
To remove the annular nut (8.2), apply a pressure slightly higher than the lower bench range value (see actuator nameplate) before disassembling actuators with fail-safe action "Actuator stem extends" and particularly actuator versions with pretensioned springs.
2. Lift actuator from the valve bonnet.

5.1 Standard valve version

5.1.1 Stuffing box packing

1. Unscrew stem connector nut and lock nut (6.1, 6.2) from the plug stem.
2. Unscrew threaded bushing (5.2).
3. Remove nuts (1.1). Lift valve bonnet (5) from the body over the plug stem.
4. Pull complete packing assembly out of the packing chamber using a suitable tool. Replace damaged parts as necessary.

Thoroughly clean the packing chamber.

5. Remove gasket (1.2) and carefully clean the sealing surfaces in the valve body and on the bonnet.
 6. Apply lubricant (order no. 8150-0111) to all parts of the packing assembly and the plug stem (6).
 7. Place a new gasket (1.2) into the valve body. Place valve bonnet (5) over the plug stem on the valve body and secure with nuts (1.1).
 8. Carefully push packing assembly (4.1, 4.3 and 4.2) over the plug stem into the packing chamber, observing the proper order.
- Screw in threaded bushing (5.2) and tighten.
9. Loosely screw lock nut (6.2) and stem connector nut (6.1) onto the plug stem.
 10. Mount actuator and adjust upper and lower bench range values as described in section 2.1.

5.1.2 Seat and/or plug

We recommend you to also replace the packing (4.2) when exchanging the seat and plug.

1. Unscrew stem connector nut and lock nut (6.1, 6.2) from the plug stem.
2. Remove threaded bushing (5.2).
3. Remove nuts (1.1). Lift valve bonnet (5) from the body over the plug stem (6).

Mixing valve

4. Unscrew top seat ring (2.1) using a SAMSON seat wrench.
5. Remove plug stem (6) together with the plug (3).

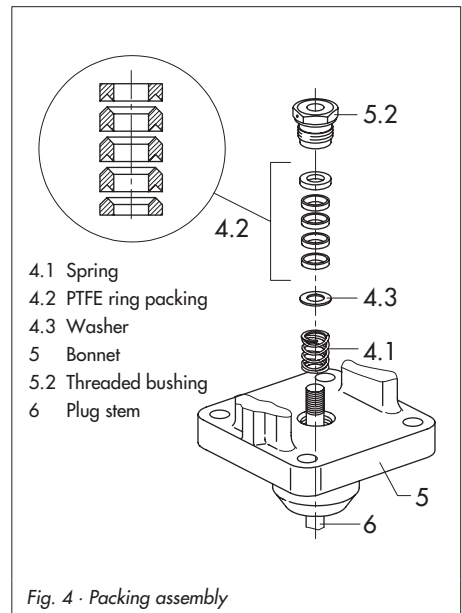

Fig. 4 · Packing assembly

6. Check seating surfaces of the seat rings. If necessary, unscrew bottom seat ring (2.2) as well and replace it.
7. Apply lubricant and sealant (order no. 8150-0119) to the thread and sealing cone of the seat rings. Also apply lubricant (order no. 8150-0111) to the plug stem.
8. Reassemble in reverse order. Observe tightening torques for seat rings and nuts of the body flanges as specified in EB 029 EN.

Flow-diverting valve

DN 32 to DN 150
(DN 15 to DN 25 as for mixing valves)

4. Remove screws (3.2). Also remove plug piece (3.1) with its sealing ring from the plug (3).
5. Proceed as described for mixing valves under items 5 to 8.
Check sealing ring when mounting the plug piece (3.1) and replace it, if necessary.

Mixing and diverting valves

9. Loosely screw lock nut (6.2) and stem connector nut (6.1) onto the plug stem.
10. Mount actuator and adjust upper and lower bench range values as described in section 2.1.

5.2 Valve with insulating section or metal bellows seal

5.2.1 Stuffing box packing

1. Unscrew stem connector nut and lock nut (6.1, 6.2) from the plug stem extension (6.3). Remove threaded bushing (5.2) of the packing.
Replace damaged parts as necessary. Thoroughly clean the packing chamber.
2. Remove bolts (5.4). Carefully lift valve bonnet (5) from the body over the plug stem extension.
3. Pull complete packing assembly out of the packing chamber using a suitable tool.
Replace damaged parts as necessary. Thoroughly clean the packing chamber.
4. Remove gasket (5.1) in the intermediate piece (12) and carefully clean the sealing surfaces.
5. Apply lubricant (order no. 8150-0111) to all parts of the packing assembly and the plug stem extension (6).
6. Place a new gasket (5.1) into the intermediate piece. Carefully place bonnet (5) over the plug stem extension onto the intermediate piece (12) and tighten with bolts (5.4).
(Tightening torques in EB 029 EN).
7. Carefully push packing assembly (4.1, 4.3 and 4.2) over the plug stem into the packing chamber observing the proper order.
Screw in threaded bushing (5.2) and tighten.
8. Loosely screw lock nut (6.2) and stem connector nut (6.1) onto the plug stem.

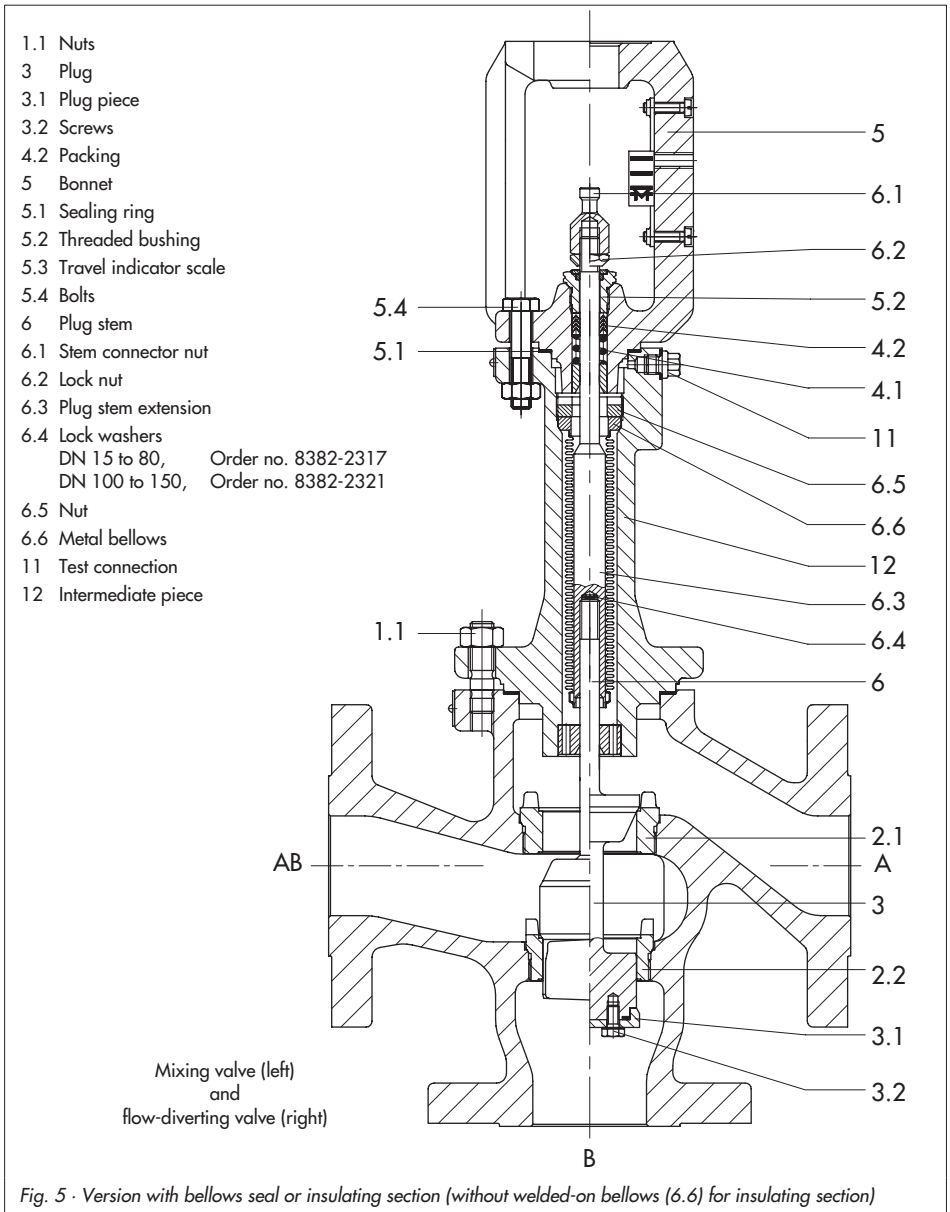

9. Mount actuator and adjust upper and lower bench range values as described in section 2.1.

5.2.2 Seat and plug

We recommend also to replace the packing (4.2) when installing a new seat and plug.



Caution!

To avoid damage in the metal bellows version (the version with insulating section does not have a bellows), make sure that no torque is applied to the bellows, which is screwed to the intermediate piece. It is recommended to use a SAMSON clamping tool.

1. Unscrew stem connector nut and lock nut (6.1, 6.2) from the plug stem.
2. Remove threaded bushing (5.2).
3. Remove bolts (5.4). Carefully lift bonnet (5) from the intermediate piece (12) over the plug stem extension (6.3).

Mixing valves

4. Insert SAMSON plug tool through valve port **B** to hold the plug stationary. Unscrew nut (6.5) using a socket wrench.
5. Tightly screw stem connector nut (6.1) and lock nut (6.2) onto the free threaded end of the plug stem extension (6.3) to hold the plug stem stationary.
6. Unscrew plug from the plug stem extension using a SAMSON plug tool.

7. Remove nuts (1.1) from the body. Lift intermediate piece (12) together with the plug stem extension (6.3) from the valve body.

If necessary, replace the metal bellows together with the plug stem extension (see section 5.2.3).

8. Unscrew top seat ring (2.1) and remove plug from the body. Unscrew bottom seat ring (2.2) as well.

Diverging valves

DN 32 to DN 150

(DN 15 to DN 25 as for mixing valves)

4. Remove screw (3.2) from the plug through valve port **B**. Take plug piece (3.1) together with the sealing ring off the plug (3).
5. Remove nuts (1.1). Also remove intermediate piece (12) together with plug stem extension, plug stem and plug (3) from the valve body (1).
6. Tightly screw stem connector nut (6.1) and lock nut (6.2) onto the free threaded end of the plug stem extension (6.3) to hold the plug stem stationary.
7. Unscrew plug (3) from the plug stem extension (6.3).
If necessary, replace the metal bellows together with the plug stem extension (see section 5.2.3).
8. Replace seats as described in section 5.2.2.
9. Apply lubricant (order no. 8150-0111) to the plug stem (6) of the new plug. Make sure that both lock washers (6.4) are still located in the plug stem exten-

sion. Tightly screw plug stem into plug stem extension (6.3) with a tightening torque of 50 Nm for \varnothing 10 mm and 80 Nm for \varnothing 16 mm.

5.2.3 Metal bellows

Refer to section 5.2.2, item 7 for mixing and flow-diverting valves.

1. Pull plug stem extension with weld-on metal bellows (6.6) out of the intermediate piece.
2. Clean seating surfaces on the intermediate piece.
3. Push new plug stem extension including metal bellows into the intermediate piece (12).

5.2.4 Reassembly

1. Place a new gasket (1.2) into the valve body. Place intermediate piece onto valve body and tighten with nuts (1.1). Observe tightening torques as specified in EB 029 EN.
2. Place a new gasket (5.1) into intermediate piece, place it on the valve bonnet (5) and fasten with nuts and bolts (5.4). Observe tightening torques as specified in EB 029 EN.
3. Tighten threaded bushing (5.2).
4. Loosely screw lock nut (6.2) and stem connector nut (6.1) onto plug stem extension (6.3) or plug stem.
5. Mount actuator and adjust upper and lower bench range values as described in section 2.1.

6 Material identifying marks

Guide bushing, seat and plug have the following identifying marks:

Guide bushing (groove on plane face)

- ▶ No groove: 1.4305
- ▶ Sharp recessed groove: 1.4571
- ▶ Flat recessed groove: Hastelloy

Seat

The material number is either stamped or engraved on the seat.

- ▶ Stellite seats are marked by a stamped-on "st".

Plug

Groove below the plug stem thread:

- ▶ No groove: 1.4006
- ▶ Sharp recessed groove: 1.4571
- ▶ Two sharp recessed grooves: 1.4301
- ▶ Flat recessed groove: Hastelloy
- ▶ When other materials are used, either the material number or its designation is engraved on the plug.

The **Kvs coefficient and characteristic** are engraved on the plug.

- ▶ Stellite plugs are marked by an engraved "st".

Dimensions and weights

Refer to the associated Data Sheet for dimensions and weights of the valve versions:

Type 3244 - DIN or ANSI T 8026 EN

Type 3246 - Class 150/300 T 8046-3 EN

7 Description of nameplates

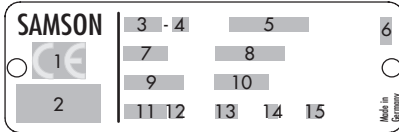

- 1 CE marking or "Art. 3, Abs.3" (see article 3, § 3 of PED), where applicable
- 2 Identification no. of notified body, fluid group and category, where applicable
- 3 Type designation
- 4 Modification index of valve
- 5 Material
- 6 Year of manufacture
- 7 Nominal size: DIN: DN, ANSI: Size
- 8 Permissible excess pressure at room temperature
DIN: PN, ANSI: CL
- 9 Order number with modification index
- 10 Position of item in order
- 11 Flow coefficient:
DIN: K_{vs} , ANSI: **C**,
- 12 Characteristic:
% equal percentage, Lin linear,
DIN: **A/Z** quick opening, ANSI: **O/C**
- 13 Sealing:
ME metal, **ST** stellited, **Ni** nickel-plated
PT soft sealing with PTFE,
PK soft sealing with PEEK
- 14 Pressure-balanced: DIN: **D**, ANSI: **B**
- 15 I or III flow divider

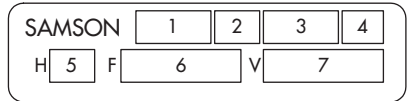

- 1 Type designation
- 2 Modification index
- 3 Effective diaphragm area
- 4 Fail-safe action:
FA Actuator stem extends
FE Actuator stem retracts
- 5 Travel
- 6 Bench range (spring range)
- 7 Bench range with pretensioned springs

SAMSON		1	
Model - No. _____			
Serial - No. _____			
Pneum. Stellantrieb	3	Hub	_____ mm
Pneum. actuator	_____ cm ²	Stroke	_____ mm
Servo - moteur pneum.	_____	Course	_____
Federbereich	_____ bar		
Spring range	_____ bar		
Plage des ressorts	_____		
Stelldruckbereich	_____ bar		
Signal pressure range	_____ bar		
Plage avec précontrainte	_____		
Zuluft max. 6 bar	Begrenzt auf _____ bar		
Air supply 90 psi	Up to _____ bar		
Air d'alimentation	Limité à _____ bar		
Made in France			

Fig. 6 · Valve nameplate (left) and actuator nameplates (right)

8 Customer inquiries

Please submit the following details:

- ▶ Order number
- ▶ Type, product number, nominal size and version of the valve

- ▶ Pressure and temperature of the process medium
- ▶ Flow rate in m³/h
- ▶ Bench range of the actuator (e.g. 0.2 to 1 bar)
- ▶ Has a strainer been installed?
- ▶ Installation drawing



SAMSON AG · MESS- UND REGELTECHNIK
Weismüllerstraße 3 · 60314 Frankfurt am Main · Germany
Phone: +49 69 4009-0 · Fax: +49 69 4009-1507
Internet: <http://www.samson.de>

EB 8026 EN

S/Z 2007-08