

Pneumatic Control Valves Type 3345-1 and Type 3345-7



Diaphragm Valve Type 3345



Type 3345-1



Type 3345-7
Version for food processing industry

Fig. 1 · Type 3345-1 and Type 3345-7 Pneumatic Control Valves

Mounting and Operating Instructions

EB 8031 EN

Edition September 2006



Contents	Page
1	Design and principle of operation 4
2	Assembling valve and actuator 4
2.1	Type 3271 and Type 3277 Actuators 4
2.2	Type 3271-5 and Type 3277-5 Actuators 6
3	Installation 7
3.1	Mounting position 7
3.2	Signal pressure line. 7
4	Operation 7
5	Maintenance 7
6	Description of nameplates. 11
7	Customer inquiries 12

Note!

*Non-electrical actuators and valves do not have their own potential ignition source according to the risk assessment in the rare incident of an operating fault, corresponding to EN 13463-1: 2001 paragraph 5.2, and therefore do **not** fall within the scope of the European Directive 94/9/EC.*

Refer to paragraph 6.3 of EN 60079-14:1977 VDE 0165 Part 1 concerning connection to equipotential bonding system.



General safety instructions

- ▶ *The control valve may only be mounted, started up or serviced by fully trained and qualified personnel, observing the accepted industry codes and practices. Make sure employees or third persons are not exposed to any danger. All safety instructions and warnings in these mounting and operating instructions, particularly those concerning assembly, start-up and maintenance, must be observed.*
- ▶ *The control valves fulfill the requirements of the European Pressure Equipment Directive 97/23/EC. Valves with a CE marking have a declaration of conformity that includes information about the applied conformity assessment procedure.
The corresponding declaration of conformity is available on request.*
- ▶ *For appropriate operation, make sure that the control valve is only used in areas where the operating pressure and temperatures do not exceed the operating values which are based on the valve sizing data submitted in the order. The manufacturer does not assume any responsibility for damage caused by external forces or any other external influence! Any hazards which could be caused in the control valve by the process medium, operating pressure, signal pressure or by moving parts are to be prevented by means of the appropriate measures.*
- ▶ *Proper shipping and appropriate storage of the control valve are assumed.*

Caution!

- ▶ *For installation and maintenance work on the valve, make sure the relevant section of the pipeline is depressurized and, depending on the process medium, drained as well. If necessary, allow the control valve to cool down or warm up to reach ambient temperature prior to starting any work on the valve.*
- ▶ *Prior to performing any work on the valve, make sure the supply air and control signal are disconnected or blocked to prevent any hazards that could be caused by moving parts.*

1 Design and principle of operation

The Type 3345-1 and Type 3345-7 Pneumatic Control Valves consist of a Type 3345 Diaphragm Valve and either a Type 3271 Pneumatic Actuator or a Type 3277 Pneumatic Actuator for integral positioner attachment.

The diaphragm stem (6) of the valve diaphragm is connected to the actuator stem (8.1) by a stem connector (7) or they are screwed together (in the stainless steel version up to DN 25). To protect the valve diaphragm, stoppers (4 and 6.3) are fitted at the top and bottom of the actuator stem.

The process medium can flow through the valve in both directions. The position of the valve diaphragm (3) determines the flow rate through the valve.

The position of the diaphragm stem (6) is changed by the signal pressure acting on the diaphragm of the actuator.

Fail-safe position

The control valve provides two different fail-safe positions depending on the arrangement of the springs in the actuator:

Actuator stem extends

When the signal pressure is reduced or the power supply fails, the springs move the actuator stem downwards and close the valve. When the signal pressure increases again, the valve opens acting against the force of the springs.

Actuator stem retracts

When the signal pressure is reduced or the power supply fails, the springs move the ac-

tuator stem upwards and open the valve. When the signal pressure increases again, the valve closes acting against the force of the springs.

2 Assembling valve and actuator

If the valve and actuator have not been assembled together by the manufacturer, or if the actuator of a control valve is to be replaced by an actuator of another type or another size, proceed as described below.

2.1 Type 3271 and Type 3277 Actuators

1. Undo the lock nut (6.2) and stem connector nut (6.1) on the diaphragm stem and thread them downwards.
Pull the diaphragm stem upwards.
2. Remove the stem connector clamps (7) and the ring nut (8.2) from the actuator (8).
Slide the ring nut over the diaphragm stem.
3. Place actuator onto the valve bonnet (5) and secure with the ring nut (8.2).
4. Read bench range and fail-safe action from the actuator's nameplate (e.g. 0.2 to 1 bar and "Actuator stem extends"). In this case, 0.2 bar corresponds to the lower bench range value to be adjusted and 1 bar corresponds to the upper bench range value.
The fail-safe action "Actuator stem extends" is indicated on the Type 3271 Actuator by FA and "Actuator stem retracts" by FE. The Type 3277 Actuator bears the corresponding symbol.

- | | | | |
|-----|------------------------|-----|--------------------|
| 1. | Valve body | 6 | Diaphragm stem |
| 1.1 | Nuts | 6.1 | Stem connector nut |
| 1.2 | Bolts | 6.2 | Lock nut |
| 2 | Compressor | 6.3 | Stopper |
| 3 | Diaphragm | 7 | Stem connector |
| 4 | Stopper | 8 | Actuator |
| 4.1 | Locking pin | 8.1 | Actuator stem |
| 5 | Valve bonnet | 8.2 | Ring nut |
| 5.1 | Wiper | 8.3 | Vent plug |
| 5.2 | Guide bushing | | |
| 5.3 | Travel indicator scale | | |
| 5.4 | Filter | | |

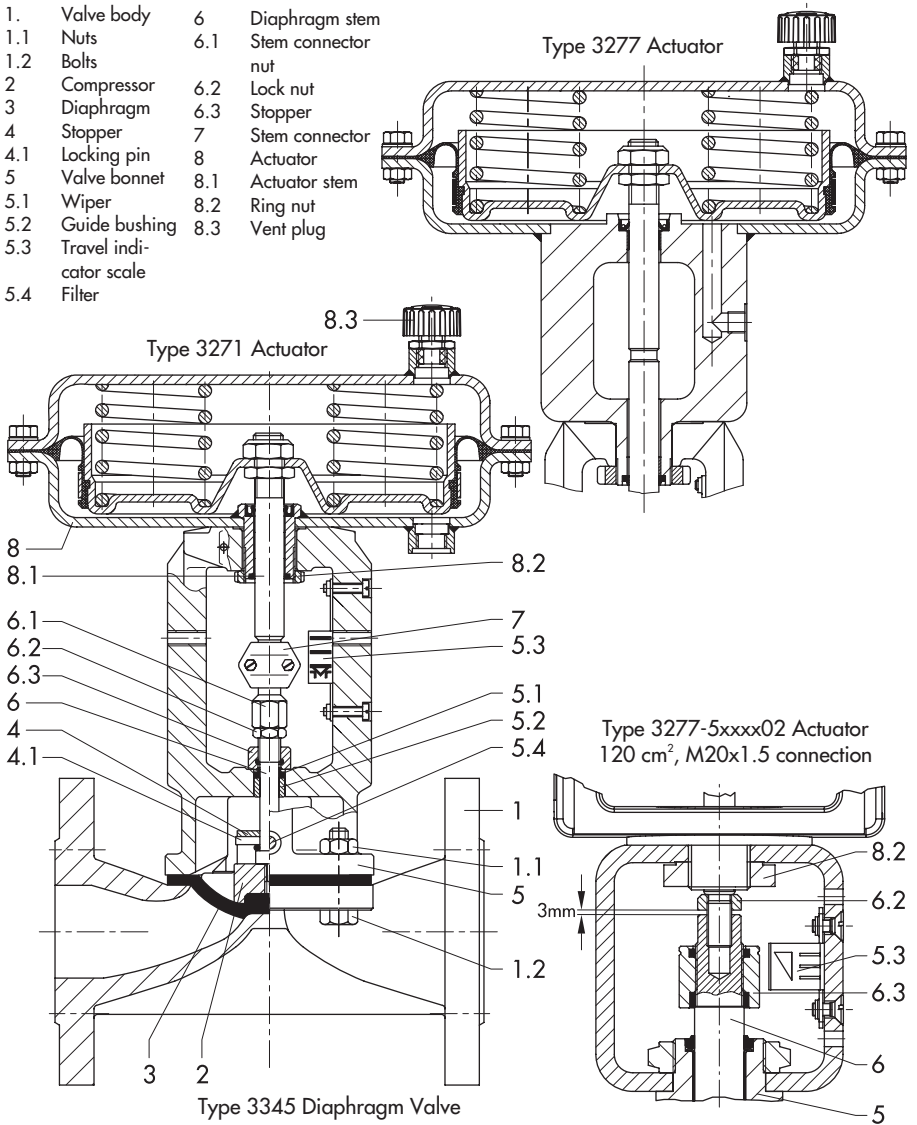

Fig. 2 · Sectional diagrams

5. For actuators with "Actuator stem extends", apply a signal pressure to the bottom diaphragm chamber which corresponds to the upper bench range value (e.g. 1 bar).

For actuators with "Actuator stem retracts", apply a signal pressure to the top diaphragm chamber which corresponds to the lower bench range value (e.g. 0.2 bar).

Travel adjustment

6. Thread down the stem connector nut (6.1) by hand until it makes contact with the actuator stem (8.1). Then, turn it another 1/4 turn and secure this position with the lock nut (6.2).
7. Position the stem connector clamps (7) and screw tight. Align the travel indicator scale (5.3) with the tip of the stem connector.
8. If, after moving the valve through the whole bench range, the travel seems to be too large or too small, adjust the stem connector nut (6.1) accordingly on the thread of the diaphragm stem. Repeat this adjustment until the required travel is achieved. Then lock this position with the lock nut.

Note on disassembling an actuator!

Before disassembling an actuator with fail-safe action "Actuator stem extends", apply a signal pressure to the bottom loading pressure connection that slightly exceeds the upper bench range value (see nameplate of the actuator) so that you can loosen the ring nut (8.2).

2.2 Type 3271-5 and Type 3277-5 Actuators

Mounting actuators on valves for food processing and valves with stainless steel bodies \leq DN 25 (Fig. 2, bottom right)

1. Thread lock nut (6.2) on the actuator stem upwards as far as it will go.
2. Pull the diaphragm stem right up to open the valve.
Slide ring nut (8.2) over the diaphragm stem (6).
3. Screw on the actuator leaving an approximate 3 mm gap between the lock nut and diaphragm stem (first apply signal pressure to an actuator with fail-safe action "Actuator stem extends").
4. Align actuator and fasten it to the yoke with the ring nut. Thread the lock nut (6.2) towards the diaphragm stem (6).
5. Align the travel indicator scale (5.3) with the ring groove of the stopper (6.3).
6. If, after moving the valve through the whole bench range, the travel seems to be too small, reduce the 3 mm gap. If the valve does not shut off tightly enough, increase the size of this gap.

3 Installation

3.1 Mounting position

The valve can be mounted in any desired position. However, an upright position with the actuator pointing upwards is preferable for valves in nominal size DN 100 or larger to facilitate maintenance. Otherwise, increased wear at the guide bushing can be expected. For actuators weighing more than 50 kg, mount a suitable support or suspension for the actuator.

Note! *Install valves for food processing in the pipeline at an approx. 20° incline to allow self-draining.*



Note!

Prior to installing valve, fit suitable spacers in the pipeline to protect the valve diaphragm from dirt, and flush the pipeline thoroughly before installation.

The valve must be installed with as little vibration as possible and free of stress.

3.2 Signal pressure line

Connect the signal pressure line to the bottom diaphragm case for valves with actuator version "Actuator stem extends" and to the top diaphragm case for valves with actuator version "Actuator stem retracts". The bottom loading pressure connection of the Type 3277 Actuator is located at the side of the yoke of the bottom diaphragm case.

4 Operation

(e.g. reversing the fail-safe action of the actuator)

For details concerning operation, see Mounting and Operating Instructions EB 8310 EN for the Type 3271 Pneumatic Actuator and EB 8311 EN for the Type 3277 Pneumatic Actuator.

5 Maintenance

The control valve is subject to natural wear, especially at the valve diaphragm.

Depending on the application, the valve needs to be checked regularly to prevent against possible failures.

If the valve shut-off is not tight enough, this may be caused by dirt or other impurities on the valve diaphragm.

Remove the parts, clean them thoroughly and replace them, if necessary.



Note!

Before performing any work on the control valve, depressurize the concerned section of the plant and drain it. Wait until the process medium has cooled down to ambient temperatures, if necessary.

Valves for food processing that have been installed at an approx. 20° incline in the pipeline still hold small amounts of the process medium, which need to be removed by a suitable cleaning procedure.

As valves are not free of cavities, there might still be residual medium in the valve.

We recommend removing the valve from the pipeline.

Caution!

On performing any work on the valve, first shut off the signal pressure, disconnect the signal pressure line and remove the actuator.

Removing the actuator: (Fig. 2)

1. Remove the stem connector clamps (7) (undo the lock nut (6.2) on Type 3277-5 Actuator) and unscrew the ring nut (8.2). Before disassembling an actuator with fail-safe action "Actuator stem extends", apply a signal pressure that slightly exceeds the upper bench range value (see nameplate) so that you can remove the ring nut (8.2).
2. Lift or unscrew the actuator from the valve bonnet.

Replacing the valve diaphragm (Figs. 2, 3 and 4)

3. Unscrew screws (1.2) or nuts and bolts (1.1) and completely lift the valve bonnet off the body.
4. Slide the diaphragm stem towards the valve body until the stopper (6.3) rests on the valve bonnet. This can be done with the actuator still mounted.
5. Remove diaphragm from the compressor (depending on the version and how it is fixed either by a screwed, bayonet or nipple connection).
6. Replace diaphragm with a new one and reassemble in reverse order as previously described.

Torque for body bolts						
DN	15	20	25	32	40	50
Nm	5	5	6	8	13	25
DN	65	80	100	125	150	–
Nm	35	50	40	45	80	–

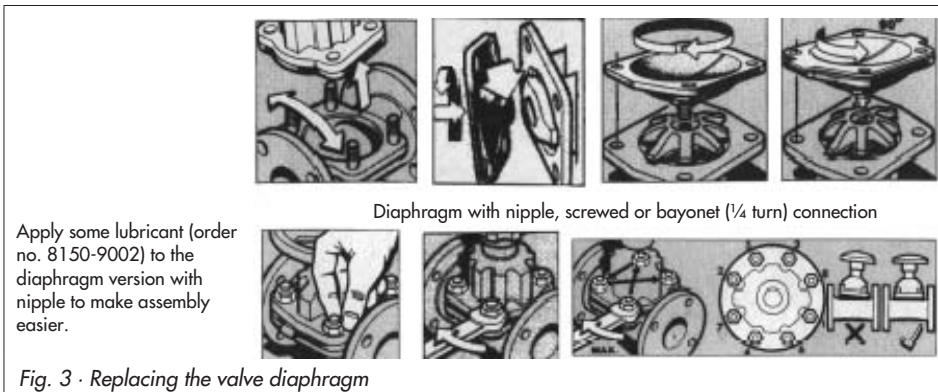

Note!

First tighten the body bolts by hand, then tighten them with a wrench in a criss-cross pattern until the diaphragm is stretched tightly. It is essential that the tightening torques listed in the table are observed. On installing the valve, recheck the tightening torques as the diaphragm may slacken after a while.

7. Mount the actuator and adjust the upper and lower bench range values as described in section 2.
8. If the position of stopper (6.3) was altered on disassembling the valve, apply a signal pressure to the actuator to make the valve close. Position stopper to rest on the valve bonnet.

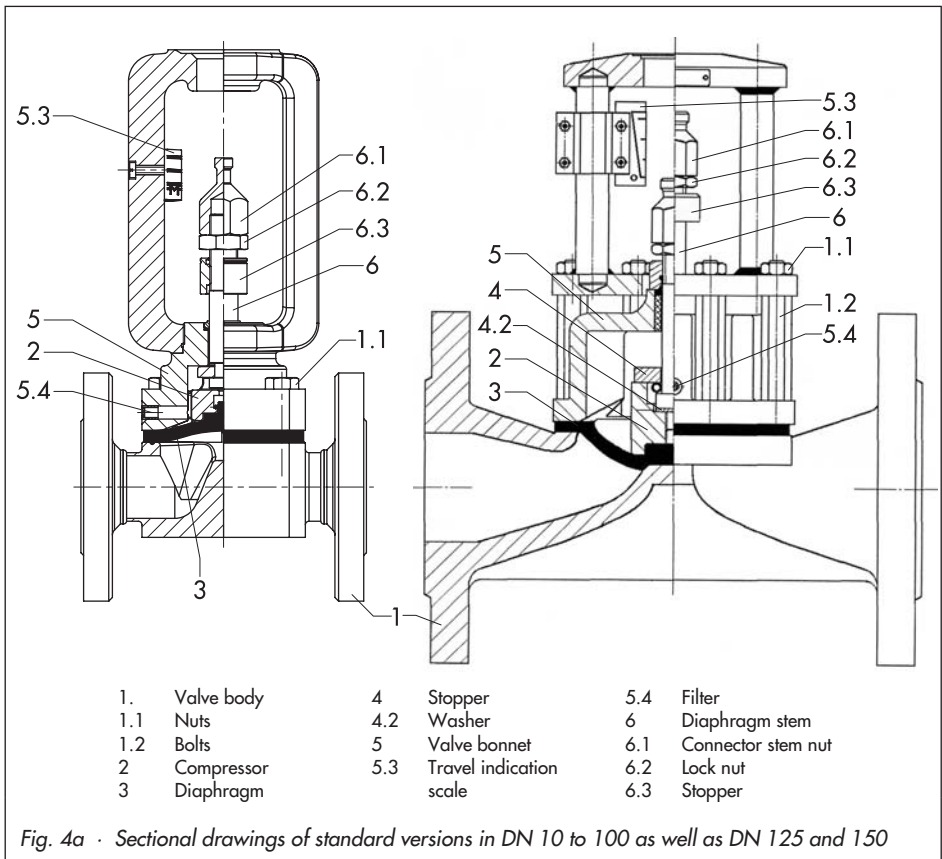
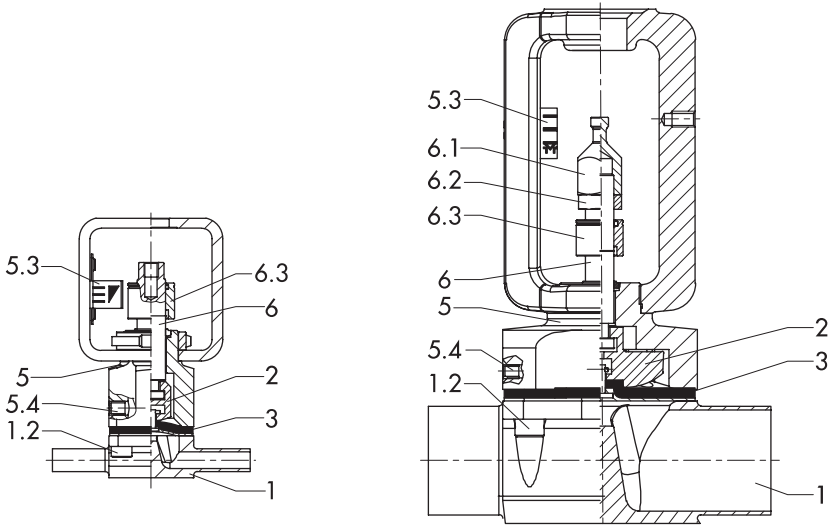

Fig. 4a · Sectional drawings of standard versions in DN 10 to 100 as well as DN 125 and 150



Valve for food processing in DN 32 to 100

- | | | |
|---------------|-----------------------------|------------------------|
| 1. Valve body | 5 Valve body | 6 Diaphragm stem |
| 1.2 Screws | 5.3 Travel indication scale | 6.1 Stem connector nut |
| 2 Compressor | 5.4 Filter | 6.2 Lock nut |
| 3 Diaphragm | | 6.3 Stopper |

Fig. 4b · Stainless steel valve for 120 cm² actuator and special version for food processing

Dimensions and weights
of the valve versions can be found in Data Sheet T 8031 EN.

6 Description of nameplates

Valves with a cast iron bonnet have a nameplate attached. Stainless steel bonnets have inscriptions written directly on the bonnet.

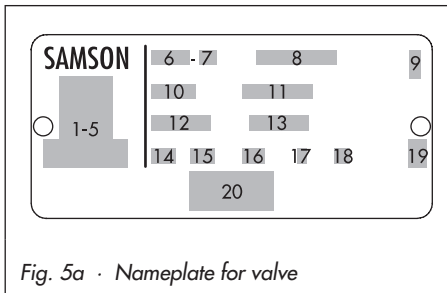

Fig. 5a · Nameplate for valve

Labeling positions for valves

- 1 to 5 Order-related specifications
CE marking or "Art. 3, Abs.3"
(see article 3, § 3 of PED)
Identification no. of notified body, fluid group
and category, where applicable
- 6 Type designation
- 7 Modification index of valve
- 8 Material
- 9 Year of manufacture
- 10 Nominal size:
DIN: DN, ANSI: NPS
- 11 Permissible excess pressure at room temp.
DIN: bar, ANSI: psi
- 12 Serial number
- 13 Unassigned
- 14 Flow coefficient: DIN: K_{vs} , ANSI: C_v
- 15 Characteristic
- 16 Travel in mm
- 17 Unassigned
- 18 Unassigned
- 19 Country of origin
- 20 Food conformity FDA, 3A

Type 3271 and Type 3277 Actuators have different nameplates.

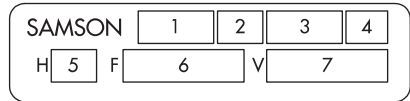

Fig. 5b · Nameplate for Type 3271 Actuator

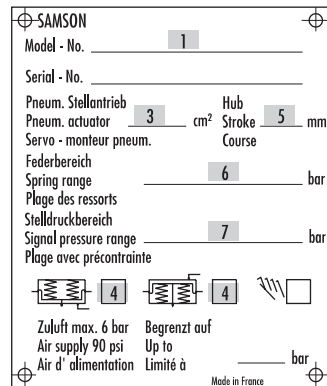

Fig. 5c · Nameplate for Type 3277 Actuator

Labeling positions for pneumatic actuators

- 1 Type designation
- 2 Modification index
- 3 Effective diaphragm area
- 4 Fail-safe action:
FA Actuator stem extends
FE Actuator stem retracts
- 5 Travel
- 6 Bench range (spring range)
- 7 Bench range with pretensioned springs

7 Customer inquiries

If you encounter any problems, please submit the following details:

- ▶ Order number
- ▶ Type, product number, nominal size and version of the valve
- ▶ Pressure and temperature of the process medium
- ▶ Flow rate in m³/h
- ▶ Bench range of the actuator (e.g. 0.2 to 1 bar)
- ▶ Installation drawing



SAMSON AG · MESS- UND REGELTECHNIK
Weismüllerstraße 3 · 60314 Frankfurt am Main · Germany
Phone: +49 69 4009-0 · Fax: +49 69 4009-1507
Internet: <http://www.samson.de>

EB 8031 EN

2006-09