

Pneumatic Control Valves Type 3251-1 and Type 3251-7



Fig. 1 · Type 3251-1

Mounting and Operating Instructions

EB 8051 EN

Edition July 2007



Contents	Page
1	Design and principle of operation 4
2	Assembling valve and actuator 4
2.1	Assembly and adjustment 4
2.2	Option to pretension the springs for actuator version "Actuator stem extends" 6
2.3	Different rated travels of valve and actuator 6
3	Installation 8
3.1	Mounting position 8
3.2	Signal pressure line. 8
3.3	Strainer, bypass 8
3.4	Test connection 8
4	Operation 8
5	Maintenance - Replacing parts 9
5.1	Replacing parts of standard valves 10
5.1.1	Packing. 10
5.1.2	Seat and/or plug 11
5.2	Replacing parts of valves with metal bellows seal 12
5.2.1	Packing. 12
5.2.2	Metal bellows 12
5.2.3	Seat and/or plug 12
5.3	Replacing parts of valves with insulating section 13
5.4	Disassembling the flow divider 13
6	Description of nameplates 14
7	Customer inquiries 15

These Mounting and Operating Instructions apply also to **Type 3246 Globe Valve** (Class 600) in conjunction with Data Sheet T 8046-2 EN.

Note!

*Non-electrical control valves that do not have a valve body lined with an **insulating material coating** do not have their own potential ignition source according to the risk assessment in the rare incident of an operating fault, corresponding to EN 13463-1: 2001 paragraph 5.2, and therefore do **not** fall within the scope of the European Directive 94/9/EC.*



General safety instructions

- ▶ *The control valve may only be mounted, started up or serviced by fully trained and qualified personnel, observing the accepted industry codes and practices. Make sure employees or third persons are not exposed to any danger.
All safety instructions and warnings in these instructions, particularly those concerning assembly, start-up and maintenance, must be observed.*
- ▶ *The control valves fulfill the requirements of the European Pressure Equipment Directive 97/23/EC. Valves with a CE marking have a declaration of conformity that includes information about the applied conformity assessment procedure.
The corresponding declaration of conformity can be viewed and downloaded on the Internet at <http://www.samson.de>.*
- ▶ *For appropriate operation, make sure that the control valve is only used in areas where the operating pressure and temperatures do not exceed the operating values which are based on the valve sizing data submitted in the order. The manufacturer does not assume any responsibility for damage caused by external forces or any other external influence! Any hazards which could be caused in the control valve by the process medium, operating pressure, signal pressure or by moving parts are to be prevented by means of the appropriate measures.*
- ▶ *Proper shipping and appropriate storage of the control valve are assumed.*

Caution!

- ▶ *For installation and maintenance work on the valve, make sure the relevant section of the pipeline is depressurized and, depending on the process medium, drained as well. If necessary, allow the control valve to cool down or warm up to reach ambient temperature prior to starting any work on the valve.*
- ▶ *Prior to performing any work on the valve, make sure the supply air and control signal are disconnected or blocked to prevent any hazards that could be caused by moving parts.*
- ▶ *Special care is needed for pneumatic control valves when the actuator springs are pretensioned. These actuators are labeled correspondingly and can also be identified by three long bolts protruding from the bottom of the actuator. Prior to starting any work on the control valve, relieve the compression from the pretensioned springs.*

1 Design and principle of operation

The Type 3251-1 and Type 3251-7 Pneumatic Control Valves consist of a single-seated Type 3251 Globe Valve and either the Type 3271 or Type 3277 Pneumatic Actuator.

The process medium flows through the valve in the direction indicated by the arrow. The position of the plug (3) determines the flow rate through the valve seat (2). The plug (3) is moved by changing the signal pressure acting on the diaphragm of the actuator (8). The plug stem (6) with the plug is connected to the actuator stem (8.1) over a stem connector (7) and sealed with spring-loaded PTFE V-ring packing (4.2) or adjustable high-temperature (HT) packing.

Fail-safe position:

Depending on how the compressed springs (8.4) are arranged in the actuator, there are two different fail-safe positions:

Actuator stem extends:

When the signal pressure is reduced or the supply air fails, the springs move the actuator stem downwards, closing the valve. The valve opens as the signal pressure increases and overcomes the force exerted by the actuator springs.

Actuator stem retracts:

When the signal pressure is reduced or the supply air fails, the springs move the actuator stem upwards, opening the valve. The valve closes as the signal pressure increases and overcomes the force exerted by the actuator springs.

2 Assembling valve and actuator

A pneumatic actuator with an additional handwheel or an electric actuator can be mounted to the valve in place of the simple pneumatic actuator.

The standard pneumatic actuator can be replaced by a larger or smaller actuator, regardless of the nominal valve size. If the travel range of the actuator is larger than that of the valve in a valve/actuator combination, the spring assembly in the actuator is preloaded by the manufacturer to make the travels match.

Each valve is equipped with the parts required for mounting its standard actuator. If you intend using a different actuator, the matching mounting parts need to be ordered together with the actuator.

The necessary parts with their order numbers can be found in the overview sheet 1 600-0501...0550 available on request. These additionally delivered parts are then used instead of the original parts.

2.1 Assembly and adjustment

If the valve and actuator have not been pre-assembled by the manufacturer or in the case that the original actuator attached to the valve is to be replaced by another actuator of a different type or size, proceed as follows:

1. Loosen the lock nut (6.2) and stem connector nut (6.1) at the valve.
Firmly press the plug and plug stem into the seat ring, then thread the stem connector nut and lock nut downwards.

2. Unscrew the parts (7) of the stem connector and the ring nut (8.2) from the actuator.
Slide the ring nut over the plug stem of the valve.
3. Place the actuator on the yoke (5.3) and screw tight using the ring nut (8.2).
4. Read the bench range (or bench range with pretensioned springs) and the actuator's fail-safe action indicated on the nameplate of the actuator (e.g. 0.2 to 1 bar and "Actuator stem extends").

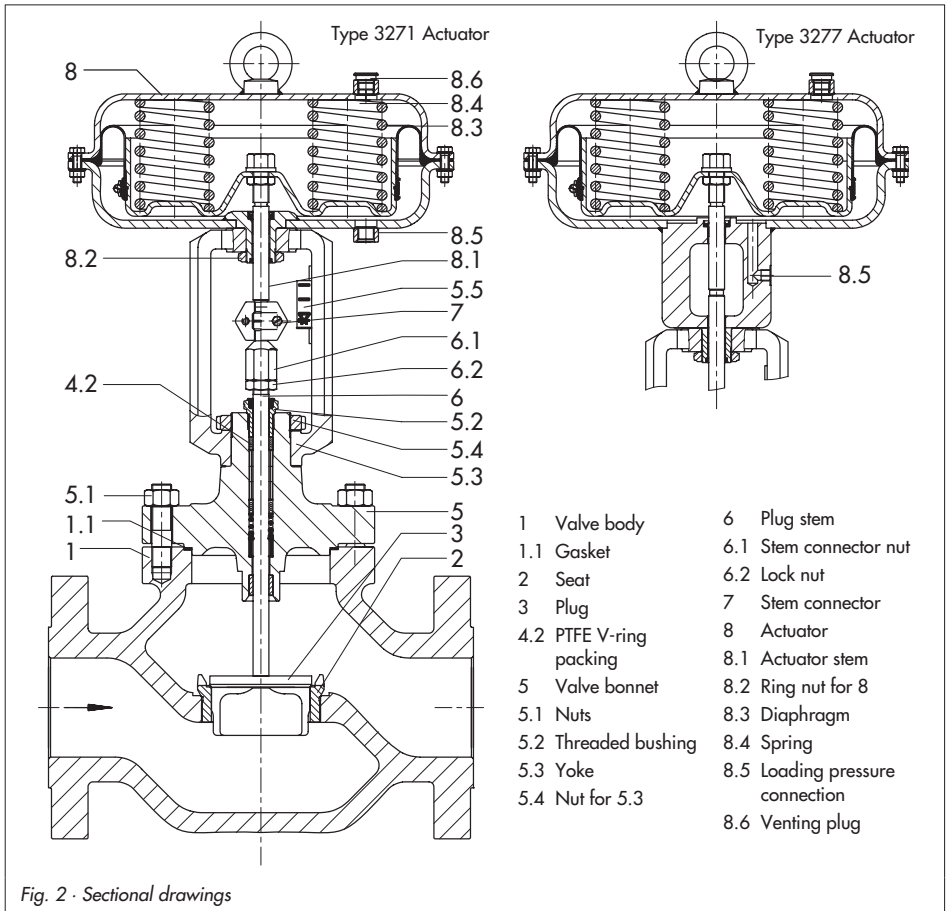

The lower bench range value (0.2 bar) corresponds to the lower range value of the signal pressure to be adjusted, the upper bench range value (1 bar) to the upper range value of signal pressure.

The fail-safe action "Actuator stem extends" or "Actuator stem retracts" is indicated by the abbreviation FA or FE on the nameplate of the Type 3271 Actuator and by a symbol on the Type 3277 Actuator.

- For actuators with "**Actuator stem extends**", apply a loading pressure corresponding to the lower signal pressure range (e.g. 0.2 bar) to the connection on the bottom diaphragm chamber. For actuators with "**Actuator stem retracts**", apply a loading pressure corresponding to the upper signal pressure range (e.g. 1 bar) to the connection on the top diaphragm chamber.
- Turn stem connector nut (6.1) by hand until it touches the actuator stem (8.1), then turn it another $\frac{1}{4}$ turn and secure this position using the lock nut (6.2).
- Attach the parts (7) of the stem connector and screw them tight. Align the travel indicator scale (5.5) with the tip on the side of the stem connector.

Note about disassembling actuators

On removing an actuator mounted on a valve, and in particular, in a version with pretensioned springs, a loading pressure slightly higher than the lower bench range (see nameplate on the actuator) must be applied to the loading pressure connection before the ring nut (8.2) can be unscrewed.

2.2 Option to pretension the springs for actuator version "Actuator stem extends"

To achieve a more powerful positioning force, the springs in the actuators can be pretensioned by up to 25 % of its travel or bench range during the valve adjustment procedure.

For example, the springs should be pretensioned by 0.1 bar for a bench range of 0.2 to 1 bar. This means the bench range is shifted by 0.1 bar to achieve a range from 0.3 to 1.1 bar (0.1 bar corresponds to pretensioning the springs by 12.5 %). On adjusting the valve, a signal pressure of 0.3 bar must now be set as the lower signal pressure range.

It is essential that the new bench range (e.g. 0.3 to 1.1 bar) is recorded on the nameplate as bench range with pretensioned springs.

2.3 Different rated travels of valve and actuator

Actuator version "Actuator stem extends"

Note!

Valves that have a smaller rated travel than that of the actuators must always use pretensioned spring ranges.

Example:

Valve DN 100 with a rated travel of 30 mm is to be mounted to an actuator 1400 cm² with a rated travel of 60 mm and a bench range from 0.4 to 2 bar.

1. Set the signal pressure required to preload the springs to 1.6 bar. This signal pressure value is above the signal pressure of 1.2 bar (range 1.2 to 2 bar) that corresponds to the mid-travel of the actuator (30 mm).
2. Thread the stem connector nut (6.1) until it touches the actuator stem.
3. Secure this position using the lock nut. Attach the stem connector as described in section 2.1.
4. Record the bench range (e.g. 1.6 to 2.4 bar) valid for the mounted valve on the nameplate of the actuator.

Actuator version "Actuator stem retracts"

Note!

The actuator springs in the version "Actuator stem retracts" cannot be pretensioned.

When a valve is mounted to a larger actuator (rated travel of the actuator is larger than that of the valve), only the first half of the actuator's bench range can be used.

Example:

Valve DN 100 with a rated travel of 30 mm and an actuator 1400 cm² with a rated travel of 60 mm and a bench range from 0.2 to 1 bar:

For mid-travel of the valve, a bench range from 0.2 to 0.6 bar can be used.



Caution!

Actuators with springs that have already been pretensioned by the manufacturer without attachment to a valve are marked by an appropriate label.

In addition, such actuators can be identified by three bolts and nuts protruding from the bottom diaphragm case.

3 Installation

3.1 Mounting position

The control valve can be mounted in any position. However, valves in nominal sizes DN 100 and larger should preferably be mounted upright with the actuator pointing upwards. This makes maintenance work easier. Valves with an insulating section or bellows seal or actuators that weigh more than 50 kg should be fitted with suitable supports or, in the case of the actuator, suspended.

Note!

The valve must be installed with the least amount of vibrations possible and without any tension.

Piping design

To allow the control valve to work properly, the pipeline upstream and downstream of the valve should be straight and free of obstructions for a length of at least 6 times the pipe diameter (DN).

Contact SAMSON if this length cannot be met during installation.

Clean out the pipeline thoroughly prior to installing the valve.

Note!

Control valves with insulating section or bellows seal may only be insulated up to the bonnet flange of the valve body for medium temperatures below 0 °C as well as temperatures above 220 °C.

Valves that should meet the requirements of NACE MR 0175 standard should not be insulated.

3.2 Signal pressure line

Connect the signal pressure line for valves with actuator version "Actuator stem extends" to the loading pressure connection on the bottom diaphragm case, and for valves with actuators "Actuator stem retracts" to the loading pressure connection on the top diaphragm case.

The lower connection of Type 3277 Actuator is located on the yoke of the bottom diaphragm case.

3.3 Strainer, bypass

We recommend installing a strainer upstream of the valve. If the plant should continue to operate during valve maintenance, install a shut-off valve both upstream of the strainer and downstream of the control valve as well as a bypass.

3.4 Test connection

Versions with a metal bellows seal (Fig. 5) include a test connection (11.1) located on the top flange to check the bellows for any leakage. We recommend connecting a suitable leakage indicator (e.g. contact pressure gauge, drainage into an open vessel or sight glass).

4 Operation

(e.g. reversing the direction of action, etc.)

For details, refer to the Mounting and Operating Instructions of the respective pneumatic actuator.

EB 8310 EN for Type 3271 and
EB 8311 EN for Type 3277.

5 Maintenance - Replacing parts

The control valve is subject to natural wear in particular at the seat and plug. Depending on the operating conditions, the valve must be checked at regular intervals to prevent problems occurring.

If any leaks occur to the atmosphere, the packing may be leaking.

If the valve does not seal properly, the tight shut-off may be impeded by dirt or other impurities caught between the seat and plug, or by damaged seating surfaces.

Remove the parts, clean them thoroughly and replace them with new ones, if necessary.



Caution!

Before servicing or disassembling the control valve, depressurize the concerned section of the plant and drain it.

Wait until the medium has cooled down, if necessary.

As the process medium cannot drain completely out of the valve, be aware that some of the process medium could still be in the valve. This is particularly the case for valve versions with bellows seals and insulating sections.

We recommend removing the valve from the pipeline.

Note!

On performing any work on the valve body, first shut off the supply pressure, disconnect the supply pressure line and remove the actuator.

Note!

Control valves fitted with a ceramic seat and plug must be handled with extreme care as they can easily break. The valve in this version cannot be remachined as described in section 5.1.2.

Note on SAMSON special tools

Suitable seat wrenches and special tools as well as the appropriate tightening torques can be found in EB 029 EN (formerly WA 29 EN). The instructions can be viewed on the Internet at www.samson.de/pdf_en/e00290en.pdf.

Removing the actuator:

1. Unscrew the ring nut (8.2) and take off the stem connector (7).
For the version "Actuator stem extends", and in particular, in a version with pretensioned springs, apply a loading pressure slightly higher than the lower bench range (see nameplate on the actuator) to the loading pressure connection to allow the ring nut (8.2) to be unscrewed.
After you have loosened the nut, disconnect the supply pressure again.
2. Remove the actuator from the valve yoke.

5.1 Replacing parts of standard valves

5.1.1 Packing

If the valve leaks at the packing, the packing (4.2) and seal elements (4.5 and 4.6) need to be replaced as follows:

Disassembly

1. Unscrew the nuts (5.1) and lift the valve bonnet (5) together with the plug stem and plug off from the valve body.
2. Unscrew the stem connector nut (6.1) and lock nut (6.2) off the plug stem. Unthread the threaded bushing (5.2) out of the packing.
3. Pull the plug together with the plug stem out of the valve bonnet.
4. Pull all the packing parts using a suitable tool out of the packing space. Replace any damaged parts with new ones. Carefully clean the packing space.

Assembly

1. Apply lubricant (order no. 8150-0111) to all parts as well as the plug stem (6). Do not use any lubricant for a graphite packing!
2. Place the plug into the valve body and insert a new gasket (1.1).
3. Place the valve bonnet carefully over the plug stem onto the valve body and screw the nuts (5.1) tight.
4. Carefully slide the packing parts over the plug stem into the packing space. Make sure the packing parts are re-

placed in the right order. Note that the number of spacers (4.3) varies depending on the nominal size.

5. Thread in the threaded bushing (5.2) and tighten it. For high-temperature packing, tighten the threaded bushing only slightly, even if it starts to leak, it should only be tightened slightly.

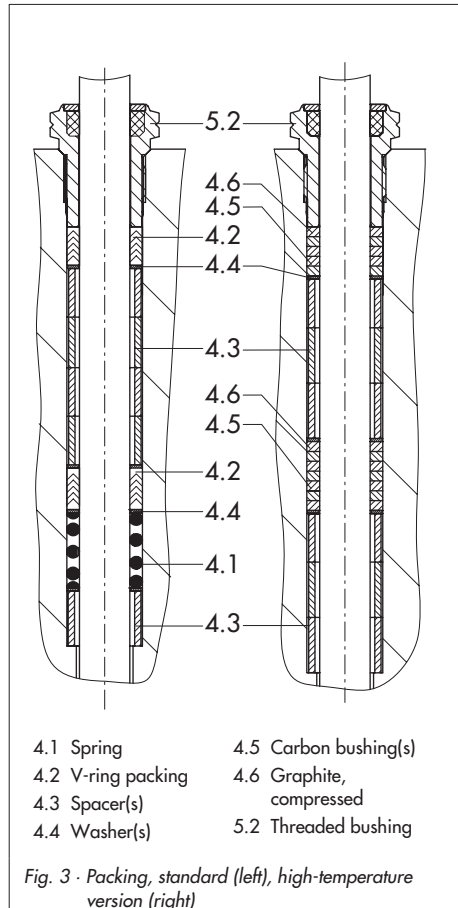

Fig. 3 - Packing, standard (left), high-temperature version (right)

- Screw the lock nut (6.2) and stem connector nut (6.1) onto the plug stem without tightening them.
- Attach the actuator as described in section 2.1 and set the lower and upper bench range.

5.1.2 Seat and/or plug

When replacing the seat or plug, we recommend replacing the packing (4.2 or 4.5 and 4.6) as well.

Seat:

- Unscrew the nuts (5.1) and lift the valve bonnet (5) together with the plug stem and plug off the valve body.
- Unscrew the seat (2) using the appropriate seat wrench (see EB 029 EN).
- Apply lubricant (order no. 8150-0119) to the thread and sealing cone of the new seat (or the old seat after it has been remachined or thoroughly cleaned) and screw it back in. The tightening torques for the seat are likewise listed in EB 029 EN.

Plug:

- Unscrew the nuts (5.1) and lift the valve bonnet (5) together with the plug stem (6) and plug off the valve body (1).
- Unscrew nuts (6.1, 6.2) and threaded bushing (5.2).
- Pull the plug out of the valve bonnet.
- Change the plug and insert the new plug and plug stem (6). It may be possible to use the old plug again after it has been

remachined. Apply lubricant (order no. 8150-0119) to the plug stem (6) before fitting it back into the valve.

Remachining the plug

The plug can be machined when the plug's seating surface is slightly damaged. Plugs with a soft sealing can only be machined up to the dimension x in Fig. 4.

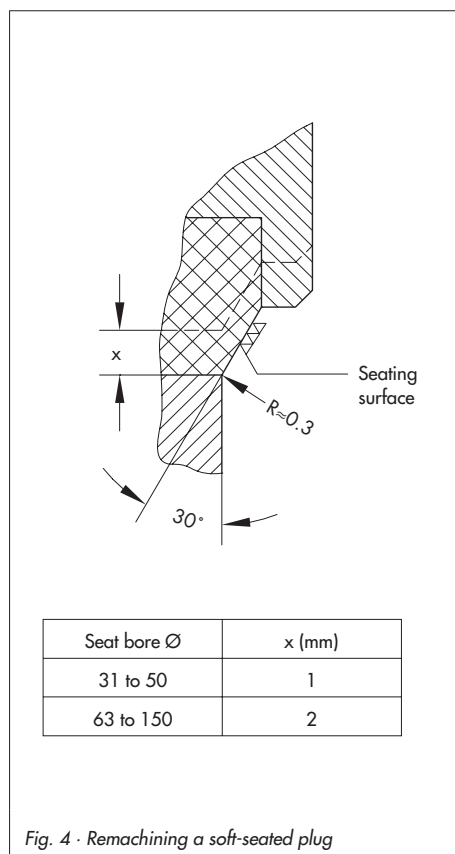

Fig. 4 · Remachining a soft-seated plug

5.2 Replacing parts of valves with metal bellows seal



Caution!

To prevent damage in the valve with bellows seal (a valve with insulating section does not contain a bellows), make sure that no torque is transferred to the bellows.

5.2.1 Packing

Replace parts as described in section 5.1.1 for the standard valve. However, unthread the threaded bushing (5.2), unscrew nuts (11.2) and separate the bonnet (11) from the intermediate piece (9).

Replace gasket (9.1) with a new one.

5.2.2 Metal bellows

The metal bellows (10) can only be replaced as an entire unit together with the plug stem. To do this, proceed as described in section 5.1.2 (Fig. 5).

5.2.3 Seat and/or plug

Replace parts as described in section 5.1.2 for the standard valve.

The plug stem can only be exchanged together with the metal bellows seal. The plug can be removed from the plug stem. For valve size DN 15 to 40, the plug is attached by a nut and for valve size DN 50 and larger, it is attached with a washer.

- ▶ Prior to attaching the plug, apply lubricant (order no. 8150-0111) to the thread of the plug stem.

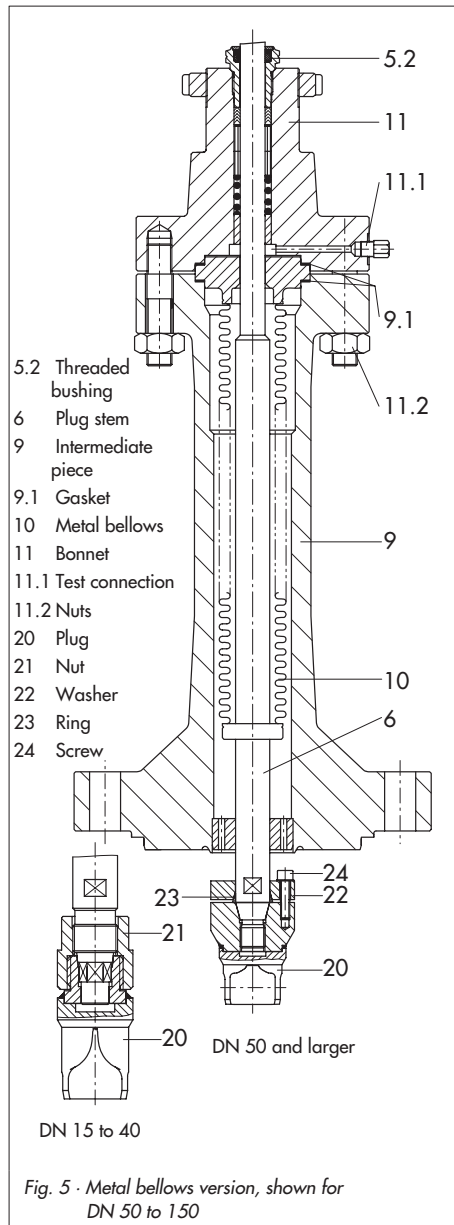

- ▶ In the version with the plug attached by a nut, screw on the nut (21) by hand on to the plug stem as far as it will go. Place the plug on the hexagonal neck of the plug stem.
- Place an open-end wrench on the flattened area of the plug stem and screw the nut onto the plug with a tightening torque of 40 Nm.

5.3 Replacing parts of valves with insulating section

Replace the packing as described in section 5.1.1 for the standard valve.

Replace the seat and plug as described in section 5.1.2 for the standard valve.

5.4 Disassembling the flow divider

For valves with flow dividers, the gasket (1.1) and shims (1.2) must be replaced with new ones every time the flow divider is removed.

The number of shims required and the dimension x must be determined when a new gasket (1.1) is used:

First measure dimension A, then dimension B.

Dimension x is calculated by $A - B$ and must be filled out with shims (0.5 or 2 mm thick). The maximum compression should be approximately 0.5 mm.

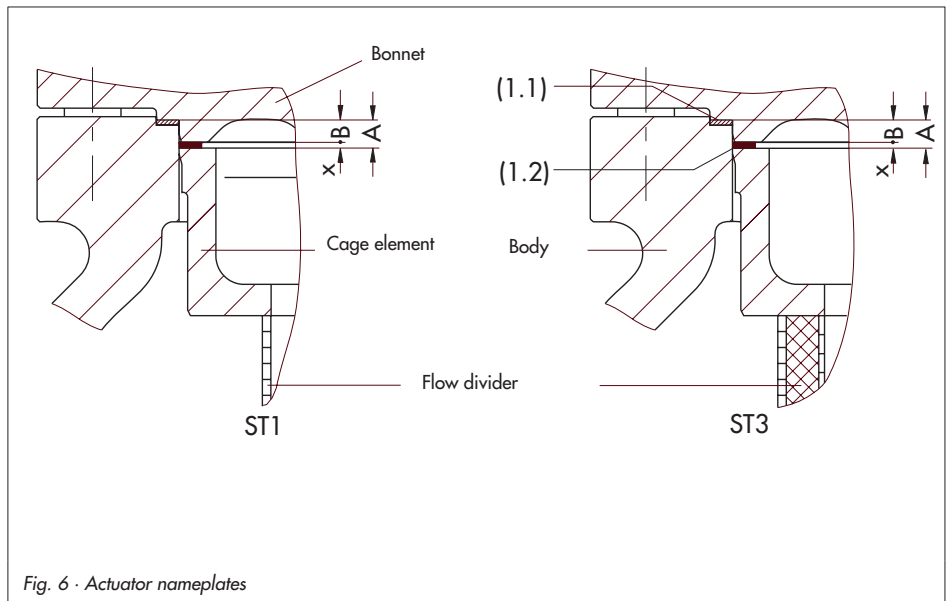
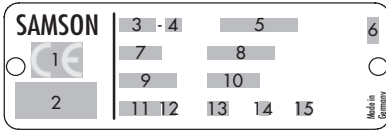

Fig. 6 · Actuator nameplates

6 Description of nameplates

Nameplate of valve



- 1 CE marking or "Art. 3, Abs.3" (see article 3, § 3 of PED), where applicable
- 2 Identification no. of notified body, fluid group and category, where applicable
- 3 Type designation
- 4 Modification index of valve
- 5 Material
- 6 Year of manufacture
- 7 Nominal size: DIN: DN, ANSI: NPS
- 8 Permissible excess pressure at room temperature
DIN: PN, ANSI: CL
- 9 Order number with modification index
- 10 Position of item in order
- 11 Flow coefficient:
DIN: K_{vs} , ANSI: C_v
- 12 Characteristic:
% equal percentage, Lin linear,
DIN: **A/Z** quick opening, ANSI: **O/C**
- 13 Sealing:
ME metal, **ST** stellited, **Ni** nickel-plated
PT soft sealing with PTFE,
PK soft sealing with PEEK
- 14 Pressure-balanced: DIN: **D**, ANSI: **B**
- 15 **III** flow divider

Nameplate of Type 3271 Actuator

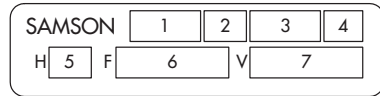

- 1 Type designation
- 2 Modification index
- 3 Effective diaphragm area
- 4 Fail-safe action:
FA Actuator stem extends
FE Actuator stem retracts
- 5 Travel
- 6 Bench range (spring range)
- 7 Bench range with pretensioned springs

Nameplate of Type 3277 Actuator

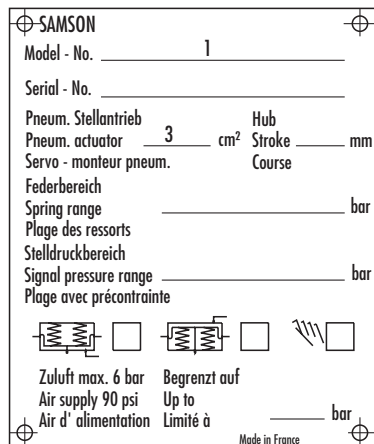

Fig. 7 · Nameplates

7 Customer inquiries

Please submit the following details:

- ▶ Order number
- ▶ Type designation, serial number, nominal size and version of the valve
- ▶ Pressure and temperature of the process medium
- ▶ Flow rate in m³/h
- ▶ Bench range of the actuator (e.g. 0.2 to 1 bar)
- ▶ Has a strainer been installed?
- ▶ Installation drawing

Dimensions and weights

Refer to the associated Data Sheet for dimensions and weights of the valve versions:

Type 3251 - DIN version	T 8051 EN
Type 3251 - ANSI version	T 8052 EN
Type 3246 - Class 600	T 8046-2 EN



SAMSON AG · MESS- UND REGELTECHNIK
Weismüllerstraße 3 · 60314 Frankfurt am Main · Germany
Phone: +49 69 4009-0 · Fax: +49 69 4009-1507
Internet: <http://www.samson.de>

EB 8051 EN

S/Z 2007-07