

Type 3254-1 and Type 3254-7 Pneumatic Control Valves

SAMSON



Mounting and Operating Instructions

EB 8060 EN

Edition August 2016

CE

Definition of signal words



DANGER!

Hazardous situations which, if not avoided, will result in death or serious injury



WARNING!

Hazardous situations which, if not avoided, could result in death or serious injury



NOTICE

Property damage message or malfunction



Note:

Additional information



Tip:

Recommended action

1	General safety instructions	4
2	Design and principle of operation	6
3	Assembling valve and actuator	8
3.1	Assembly and adjustment	8
3.2	Option of preloading springs for "actuator stem extends"	9
3.3	Different rated travels of valve and actuator	9
4	Installation	10
4.1	Mounting position	10
4.2	Signal pressure line	10
4.3	Strainer and bypass	10
4.4	Test connection	11
5	Operation	11
6	Maintenance	11
6.1	Replacing parts in standard valves	12
6.1.1	Packing	12
6.1.2	Seats and/or plugs	13
6.2	Replacing parts in valves with bellows seal	13
6.2.1	Packing	13
6.2.2	Metal bellows	13
6.3	Replacing parts in valves with insulating section	14
6.4	Removing the flow divider	15
7	Nameplates	16
8	Technical data	17
9	Customer inquiries	17

1 General safety instructions

- The control valve must be mounted, started up, or serviced by fully trained and qualified personnel only; the accepted industry codes and practices are to be observed. Make sure employees or third persons are not exposed to any danger. All safety instructions and warnings given in these mounting and operating instructions, particularly those concerning installation, start-up and maintenance, must be strictly observed.
- The control valves comply with the requirements of the European Pressure Equipment Directive 2014/68/EU. Valves with a CE marking have a declaration of conformity, which includes information about the applied conformity assessment procedure. The declaration of conformity can be viewed and downloaded at ► <http://www.samson.de>.
- To ensure appropriate use, only use the valve in applications where the operating pressure and temperatures do not exceed the specifications used for sizing the valve at the ordering stage. The manufacturer does not assume any responsibility for damage caused by external forces or any other external factors.
- Any hazards that could be caused in the valve by the process medium, the operating pressure, the signal pressure or by moving parts are to be prevented by taking appropriate precautions.
- Proper shipping and storage are assumed.



WARNING!

- *For installation and maintenance, make sure the relevant section of the pipeline is depressurized and, depending on the process medium, drained as well. Depending on the field of application, allow the valve to cool down or heat up to reach ambient temperature before starting any work on it.*
- *When working on the valve, make sure that the pneumatic air supply as well as the control signal are disconnected to prevent any hazards caused by moving parts.*
- *Be particularly careful if the actuator springs are preloaded. Such actuators are labeled correspondingly and can also be identified by three long bolts protruding from the bottom of the actuator. Before starting any work on the valve, relieve the compression from the preloaded springs.*



Note:

Non-electric control valve versions whose bodies are not lined with an insulating material coating do not have their own potential ignition source according to the risk assessment stipulated in EN 13463-1: 2001, section 5.2, even in the rare incident of an operating fault. Therefore, such valve versions do not fall within the scope of Directive 2014/34/EU.

2 Design and principle of operation

The Type 3254-1 and Type 3254-7 Pneumatic Control Valves consist of the single-seated Type 3254 Globe Valve and either a Type 3271 or Type 3277 Pneumatic Actuator.

The medium flows through the valve in the direction indicated by the arrow. The plug (3) is moved by changing the signal pressure acting on the diaphragm of the actuator (8).

The plug stem (6) together with the plug is connected with the actuator stem (8.1) by the stem connector (7) and sealed by either a spring-loaded PTFE V-ring packing (4.2) or by an adjustable high-temperature packing.

Fail-safe position

Depending on how the compression springs (8.3) are arranged in the actuator, the valve has two different fail-safe positions:

- **Actuator stem extends:** when the signal pressure is reduced or the air supply fails, the springs move the actuator stem downward and close the valve.

The valve opens when the signal pressure is increased enough to overcome the force exerted by the springs.

- **Actuator stem retracts:** when the signal pressure is reduced or the air supply fails, the springs move the actuator stem upward and open the valve.

The valve closes when the signal pressure is increased enough to overcome the force exerted by the springs.

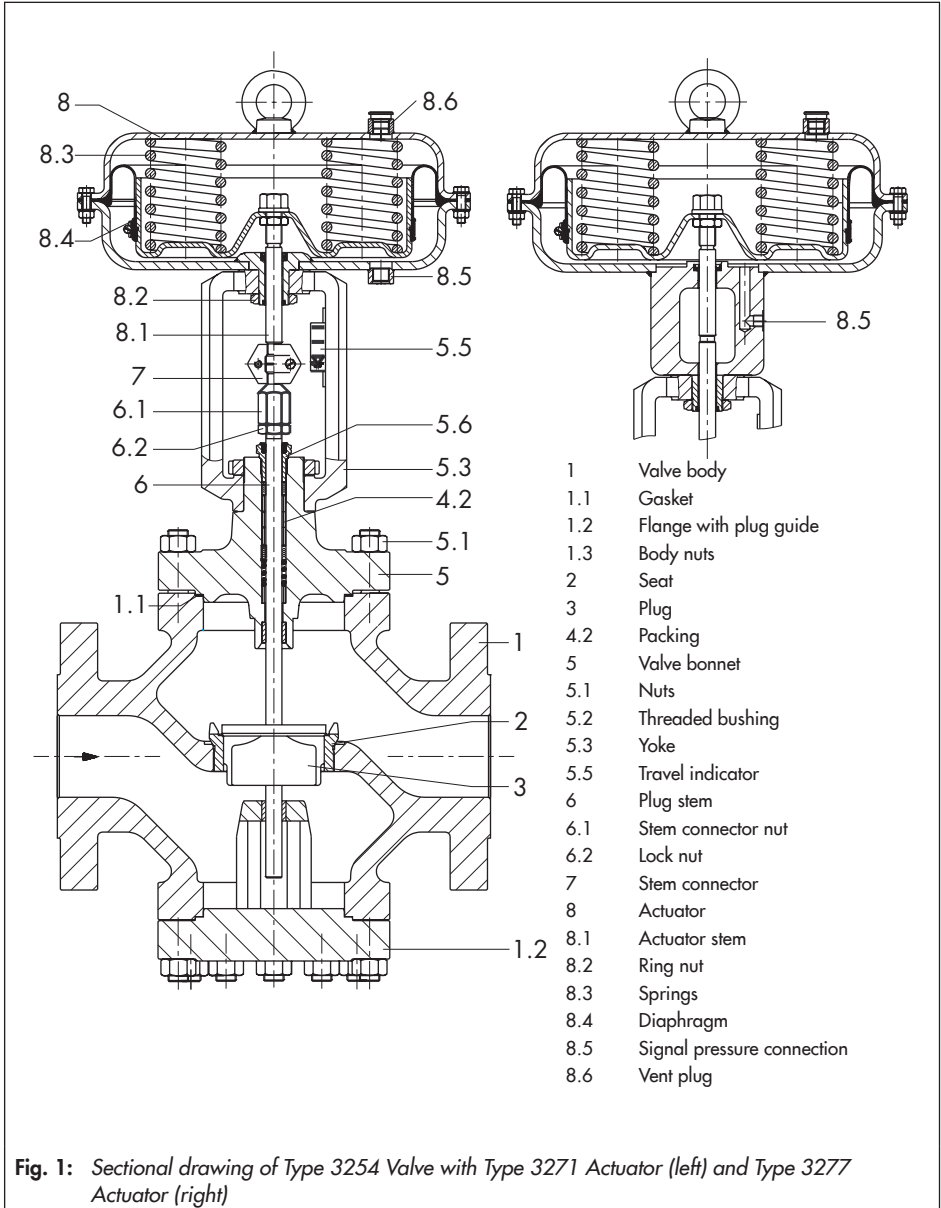

Fig. 1: Sectional drawing of Type 3254 Valve with Type 3271 Actuator (left) and Type 3277 Actuator (right)

3 Assembling valve and actuator

The basic pneumatic actuator can be replaced by a pneumatic actuator with additional handwheel or by an electric actuator.

The standard pneumatic actuator can be replaced by a smaller or larger actuator for all nominal valve sizes.

If the travel range of the actuator is larger than the travel of the valve, the springs in the actuator are preloaded by SAMSON so that the travel ranges match.

Each valve is supplied with the parts required for its standard actuator. If you intend to use a different actuator, order the required mounting parts together with the actuator.

The required parts and their order numbers can be found in the overview 1600-0501 to 0550, which is available on request. In this case, the original parts are exchanged for the additionally delivered parts.

3.1 Assembly and adjustment

Proceed as follows if the valve and actuator have not been assembled by SAMSON or if the actuator is to be replaced by an actuator of another type or size:

1. Loosen the lock nut (6.2) and stem connector nut (6.1) on the valve. Firmly press the plug and plug stem into the seat ring and screw the lock nut and stem connector nut downward.
2. Remove the stem connector clamps (7) and the ring nut (8.2) from the actuator.

Slide the ring nut over the valve's plug stem.

3. Place the actuator onto the yoke (5.3) and secure it with the ring nut (8.2).
4. Read the bench range (or bench range with preloaded springs) and the actuator's fail-safe action from the actuator's nameplate (e.g. 0.2 to 1 bar and "actuator stem extends").

The lower value (0.2 bar) corresponds to the lower bench range value to be adjusted, whereas the upper value (1 bar) corresponds the upper bench range value.

The fail-safe action "actuator stem extends" (FA) or "actuator stem retracts" (FE) is marked by FA or FE on the Type 3271 Actuator, and by a symbol on the nameplate of the Type 3277 Actuator.

For actuators with "actuator stem extends" fail-safe action, apply a signal pressure that corresponds to the lower bench range value (e.g. 0.2 bar) to the connection on the bottom diaphragm chamber.

For actuators with "actuator stem retracts" fail-safe action, apply a signal pressure that corresponds to the upper bench range value (e.g. 1 bar) to the connection on the top diaphragm chamber.

5. Screw on the stem connector nut (6.1) by hand until it touches the actuator stem (8.1). Turn it a further $\frac{1}{4}$ turn and secure this position with the lock nut (6.2)

6. Position the stem connector clamps (7) and screw them tight. Align the travel indicator scale (5.5) with the tip of the stem connector clamp.



Note on removing an actuator:

When removing an actuator from a valve, especially an actuator with preloaded springs, apply a signal pressure that is slightly higher than the lower bench range value (see actuator nameplate) to the signal pressure connection so that the ring nut (8.2) can be unscrewed.

3.2 Option of preloading springs for "actuator stem extends"

To achieve a greater positioning force, the springs of these actuators can be preloaded by up to 25 % of their travel or their bench range.

When a preload of, e.g. 0.1 bar, is desired for a bench range of 0.2 to 1 bar, the lower bench range value is shifted by 0.1 bar to 0.3 bar (0.1 bar correspond to a preload of 12.5 %).

When adjusting the valve, set the lower bench range value to 0.3 bar. Write the new bench range with preloaded springs of 0.3 to 1.1 bar on the nameplate.

3.3 Different rated travels of valve and actuator

Valve with actuator with "stem extends" fail-safe action



NOTICE

Always use actuators with preloaded springs when the valve's rated travel is smaller than the rated travel of the actuator.

Example: DN 100 valve with 30 mm rated travel and 1400 cm² actuator with 60 mm rated travel; 0.4 to 2 bar bench range.

1. Set the signal pressure required for preloading from 1.2 bar (1.2 to 2 bar), which corresponds to half the actuator's travel (30 mm), to 1.6 bar.
2. Screw on the stem connector nut (6.1) until it touches the actuator stem.
3. Secure this position with the lock nut and mount the stem connector as described in section 3.1.
4. Write the bench range of 1.6 to 2.4 bar valid for the assembled control valve on the actuator's nameplate.

Valve with actuator with "stem retracts" fail-safe action



Note

The springs of actuators with "Actuator stem retracts" cannot be preloaded.

When a valve is combined with an oversized actuator (rated actuator travel larger than rated valve travel), only the first half of the actuator's bench range can be used.

Example: DN 100 valve with 30 mm rated travel and 1400 cm² actuator with 60 mm rated travel; 0.2 to 1 bar bench range.

At half the valve travel, the usable bench range is between 0.2 and 0.6 bar.



WARNING!

Actuators that have already been preloaded by the manufacturer without mounting the valve are labeled correspondingly. Additionally, they can be identified by three longer bolts with nuts protruding from the bottom diaphragm case.

4 Installation

4.1 Mounting position

The valve can be mounted in any desired position. However, we recommend installing valves in sizes larger than DN 100 with the actuator pointing upward. Otherwise, it will be more difficult to perform maintenance work on the valve. For valves fitted with an insulating section or bellows seal and for actuators weighing more than 50 kg, the actuator needs to be supported or suspended.



NOTICE

- Install the valve free of stress.
- Flush the pipeline thoroughly before installing the valve.



Note

Only insulate control valves with insulating section or bellows seal up to the bonnet flange of the valve body for medium temperatures below 0 °C and above 220 °C.

Do not insulate valves mounted to comply with NACE MR0175 requirements.

4.2 Signal pressure line

Connect the signal pressure line for valves with an actuator with "stem extends" fail-safe action to the connection on the bottom diaphragm case, and for valves with an actuator with "stem retracts" fail-safe action to the connection on the top diaphragm case.

In the Type 3277 Actuator, the lower signal pressure connection is located at the side of the yoke under the bottom diaphragm case.

4.3 Strainer and bypass

We recommend installing a strainer upstream of the valve. We recommend installing a shut-off valve both upstream of the strainer and downstream of the valve to ensure that the plant does not need to be shut down for maintenance. In addition, install a bypass line.

4.4 Test connection

Versions with bellows seal (Fig. 3) are fitted with a test connection (11.1) at the top flange to monitor the tightness of the bellows. Particularly for liquids and vapors, we recommend installing a suitable leakage indicator, such as a contact pressure gauge, an outlet to an open vessel or an inspection glass.

5 Operation

(e.g. reversing the direction of action etc.)
Refer to the operating and mounting instructions of the pneumatic actuator, e.g.

► EB 8310-X for Type 3271 and Type 3277

6 Maintenance

The control valve is subject to normal wear, especially at the seat, plug, and packing. Depending on the operating conditions, check the valve at regular intervals to prevent possible failure before it can occur. External leakage can indicate that the packing is defective. If the valve does not close tightly, tight shut-off may be impaired by dirt stuck between the seat and plug or by damaged facings.

We recommend removing the parts, cleaning them, and, if necessary, replacing them with new ones.



WARNING!

Before performing any work on the control valve, depressurize the relevant plant section and, depending on the process medium, drain it as well. When used at high temperatures, allow the plant section to cool down to ambient temperature.

Valves are not free of cavities. As a result, residual process medium might still be contained in the valve. This applies to valve versions with insulating section in particular. We recommend removing the valve from the pipeline.

Before starting any work on the valve body, disconnect the signal pressure and remove the signal pressure line as well as the actuator.



Note on special SAMSON tools:

Suitable seat wrenches and special tools as well as the associated tightening torques are listed in EB 029 (previously WA 029). The document is available at http://www.samson.de/pdf_en/e00290en.pdf.

Removing the actuator

1. Remove the stem connector (7) and unscrew the ring nut (8.2).

For actuators with "stem extends" fail-safe action and particularly for actuators with preloaded springs, apply a signal pressure that is higher than the lower

bench range value (see nameplate) beforehand.

2. Lift the actuator off the valve yoke.

6.1 Replacing parts in standard valves

6.1.1 Packing

If the packing leaks, replace the packing (4.2) and the sealing parts (4.5 and 4.6) as follows:

Disassembly

1. Unscrew the nuts (5.1) and lift the valve bonnet (5) together with the plug stem and plug off the body.
2. Unscrew the lock nut (6.2) and stem connector nut (6.1) from the plug stem. Unscrew the threaded nut (5.2) of the packing.
3. Pull the plug together with the plug stem out of the valve bonnet.
4. Pull the entire packing out of the packing chamber using a suitable tool and replace damaged parts.
5. Clean the packing chamber thoroughly.

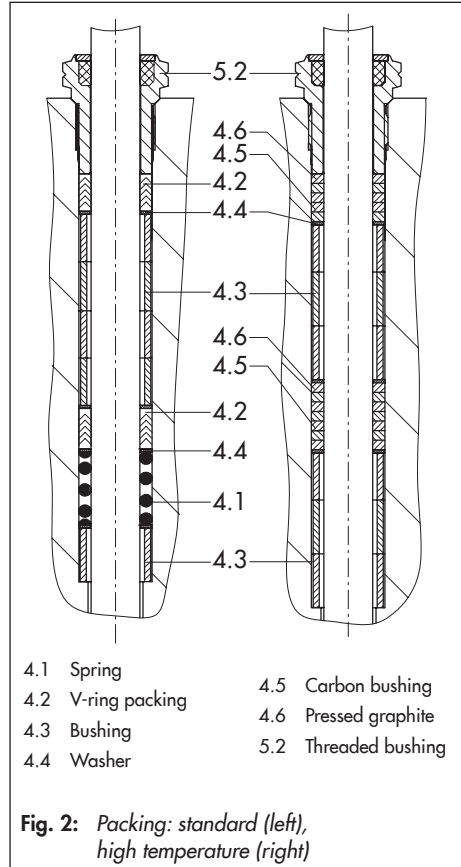

Fig. 2: Packing: standard (left), high temperature (right)

Assembly

1. Apply a suitable lubricant to all the parts and to the plug stem (6). Do not use lubricant on graphite packings.
2. Place plug into the valve body and insert a new gasket (1.1).
3. Carefully slide the valve bonnet over the plug stem onto the valve body and secure it with nuts (5.1).

4. Carefully slide the packing parts over the plug stem into the packing chamber.
Observe the proper sequence. The number of spacer bushings (4.3) may vary depending on the nominal valve size.
5. Screw in the threaded bushing (5.2) and tighten it.
For high-temperature packings, only tighten the threaded bushing slightly; in case of leakage, also retighten it only slightly.
6. Loosely screw the lock nut (6.2) and stem connector nut (6.1) onto the plug stem.
7. Mount the actuator as described in section 3.1 and adjust the upper and lower bench range values.

6.1.2 Seats and/or plugs

When replacing the seat or plug, we also recommend replacing the packing parts (4.2 or 4.5 and 4.6).

Seat:

1. Unscrew the nuts (5.1) and lift the valve bonnet (5) together with the plug stem and plug off the body.
2. Unscrew the seat (2) with a suitable seat wrench (document EB 029).
3. Apply a suitable lubricant to the thread and the sealing cone of the new seat. Screw in the seat. For the tightening torques refer to document EB 029.

Plug:

1. Unscrew the nuts (5.1) and lift the valve bonnet (5) together with the plug stem (6) and plug off the body (1).
2. Unscrew nuts (6.1, 6.2) and threaded bushing (5.2).
3. Pull the plug out of the valve bonnet.
4. Replace the old plug with a new plug (3) with plug stem (6).
Apply a suitable lubricant to the plug stem (6) before insertion.

6.2 Replacing parts in valves with bellows seal

6.2.1 Packing

1. Replace the packing as described for the standard version in section 6.1.1, however, remove the nuts (11.2) and separate the bonnet (11) from the intermediate piece (9).
2. Replace the gasket (9.1).

Do not separate the bonnet from the intermediate piece unless to replace the packings.

6.2.2 Metal bellows

The metal bellows (10) can only be replaced as a unit together with the plug stem. Proceed as described in section 6.1.2 (Fig. 3).



NOTICE

Do not transmit any torque to the metal bellows during assembly or disassembly of the bellows seal.

6.3 Replacing parts in valves with insulating section

- Replace the packing as described for the standard version in section 6.1.1.
- Replace the seat and plug as described for the standard version in section 6.1.2.

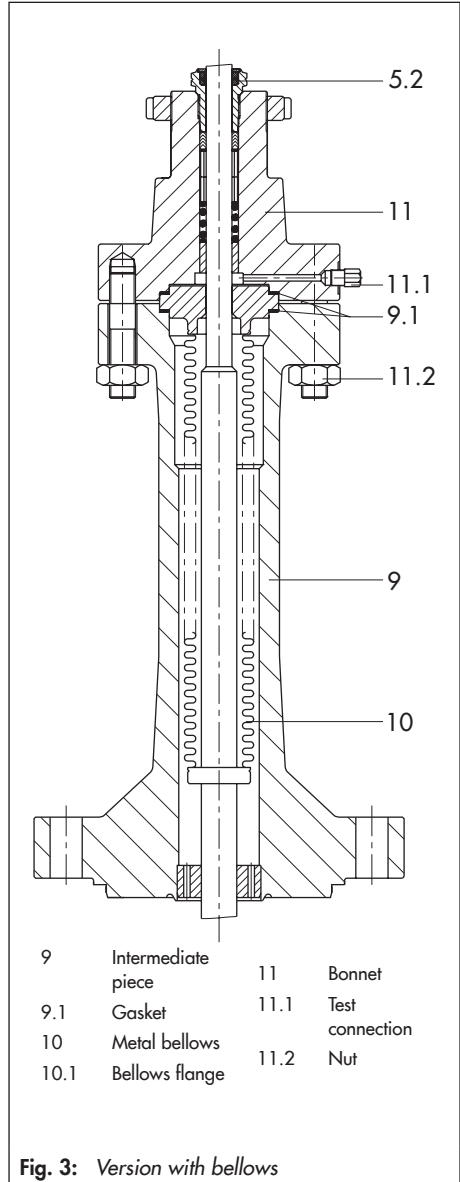

Fig. 3: Version with bellows

6.4 Removing the flow divider

For versions with a flow divider, the flange gasket (1.3) and shims (1.4) must be renewed each time the flow divider is disassembled. Before inserting a new gasket (1.3), measure the dimension x and establish how many shims are needed.

First measure dimension A and then dimension B .

Dimension x results from the difference between A and B and must be filled up with shims (0.5 to 2 mm thick).

The maximum compression of the shims is approx. 0.5 mm.

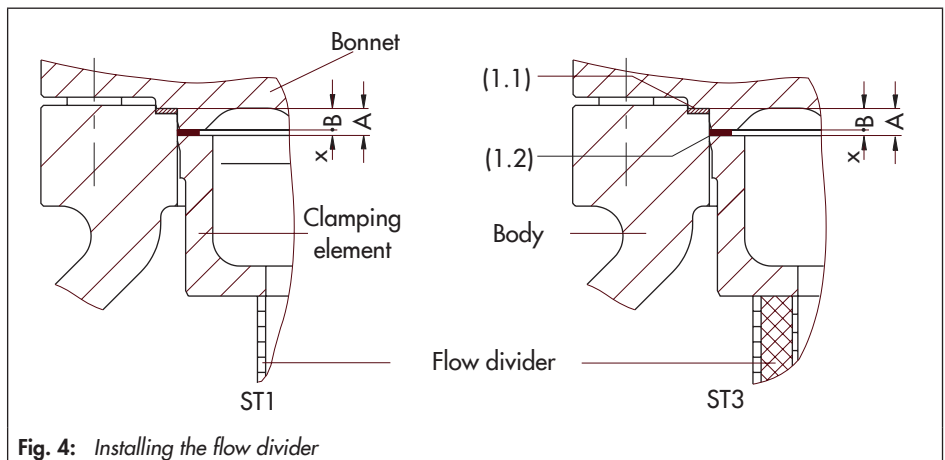
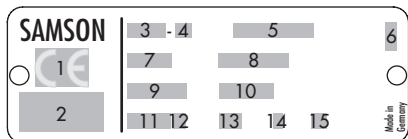

Fig. 4: Installing the flow divider

7 Nameplates

Valve nameplate



- 1 CE marking or "Art. 4, Abs. 3", where applicable
- 2 ID of the notified body, fluid group and category, where applicable
- 3 Type designation
- 4 Device modification index
- 5 Material
- 6 Year of manufacture
- 7 Valve size: DIN: **DN**, ANSI: **NPS**
- 8 Perm. operating gauge pressure at room temperature
DIN: **PN**, ANSI: **CL**
- 9 Order no. with modification index
- 10 Order pos.
- 11 Flow coefficient:
DIN: **K_{vs}**, ANSI: **C_v**
- 12 Characteristic:
% equal percentage, Lin linear,
DIN: **A/Z** (quick opening)
ANSI: **O/C** (quick opening)
- 13 Plug seal:
ME_{xx} Metal
ST Stellite® facing
Ni Nickel-plated
PT Soft seal with PTFE
PK Soft seal with PEEK
- 14 Pressure balancing
DIN: **D**; ANSI: **B**
- 15 Flow divider
I or **III**

Nameplate of Type 3271 Actuator

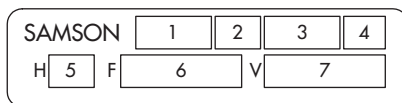

- 1 Type designation
- 2 Modification index
- 3 Actuator area
- 4 Direction of action:
FA Actuator stem extends
FE Actuator stem retracts
- 5 Travel
- 6 Bench range
- 7 Bench range with preloaded springs

Nameplate of Type 3277 Actuator

SAMSON	
Model - No. _____	1 _____
Serial - No. _____	
Pneum. Stellantrieb	Hub _____ mm
Pneum. actuator _____	Stroke _____ mm
Servo - monteur pneum.	Course _____
Federbereich _____	_____ bar
Spring range _____	_____ bar
Plage des ressorts _____	_____ bar
Stelldruckbereich _____	_____ bar
Signal pressure range _____	_____ bar
Plage avec précontrainte _____	_____ bar
Zuluft max. 6 bar	Begrenzt auf _____ bar
Air supply 90 psi	Up to _____ bar
Air d' alimentation	Limité à _____ bar
Made in France	

Fig. 5: Nameplates

8 Technical data

The technical data as well as the dimensions and weights for the DIN and ANSI versions of the Type 3254 Valve are listed in the corresponding Data Sheets ► T 8060 and ► T 8061.

Compliance

The Type 3254 Valve bears both the CE and EAC marks of conformity:



9 Customer inquiries

Please submit the following details:

- Order number
- Type, model number, nominal size, and valve version
- Pressure and temperature of the process medium
- Flow rate in m³/h
- Bench range (e.g. 0.2 to 1 bar) of the mounted actuator
- Is a strainer installed?
- Installation drawing



SAMSON AG · MESS- UND REGELTECHNIK
Weismüllerstraße 3 · 60314 Frankfurt am Main, Germany
Phone: +49 69 4009-0 · Fax: +49 69 4009-1507
samson@samson.de · www.samson.de

EB 8060 EN

2016-10-14 · English