

Pneumatic Control Valve Type 3510-1 and Type 3510-7



Type 3510-7 with 120 cm² actuator
and integrated positioner



Type 3510-1 with 60 cm² actuator



Type 3510-1 with 120 cm² actuator

Fig. 1 · Pneumatic control valves

Mounting and Operating Instructions

EB 8091 EN

Edition July 2002

Contents		Page
1	Design and principle of operation	4
2	Assembling and adjusting valve and actuator	6
2.1	Signal pressure connection	6
2.2	Assembly and adjustment	7
3	Installation	8
3.1	Mounting position	8
4	Operation – Reversing the operating direction	8
5	Troubleshooting	9
5.1	Replacing the stuffing box packing	10
5.2	Replacing seat and plug	12
6	Customer inquiries	14

Note!

*Non-electrical control valves which do not have a valve body lined with an **insulating material coating** do not have their own potential ignition source according to the risk assessment in the rare incident of an operating fault, corresponding to EN 13463-1: 2001 paragraph 5.2, and therefore do not fall within the scope of the European Directive 94/9/EC.*



- ▶ *The device may only be assembled, started up or operated by trained and experienced personnel familiar with the product.
According to these mounting and operating instructions, trained personnel is referred to as individuals who are able to judge the work they are assigned to and recognize possible dangers due to their specialized training, their knowledge and experience, as well as their knowledge of the applicable standards.*
 - ▶ *Any hazards which could be caused in the control valve by the process medium, the operating pressure, the signal pressure or the moving parts are to be prevented by means of the appropriate measures.
In addition, it is necessary to make sure that the control valve is only used in areas where the operating pressure and temperatures do not exceed the operating values which are based on the valve sizing data submitted in the order.*
 - ▶ *Proper shipping and appropriate storage are assumed.*
-

1 Design and principle of operation

The pneumatic control valve consists of a Type 3510 Micro-flow Valve (globe or angle body style) and either a Type 3271-5 Pneumatic Actuator (Type 3510-1 Control Valve) or a Type 3277-5 Pneumatic Actuator (Type 3510-7 Control Valve).

The modular design enables the actuators to be exchanged, and the standard valve version to be enhanced to a version incorporating either a bellows seal or an insulating section.

The process medium flows through the valve in the direction indicated by the arrow. The position of the valve plug (3) determines the cross-sectional area of flow between the

valve seat (2) and the plug.

A change in the signal pressure acting on the diaphragm of the actuator causes the valve plug to move correspondingly. The plug stem (6) is connected to the actuator stem (8.1) via the stem connector (7) and sealed with an adjustable stuffing box with packing that contains PTFE sealing rings.

Fail-safe action:

Depending on the arrangement of the springs (8.3) in the actuator, the control valve has two different fail-safe actions:

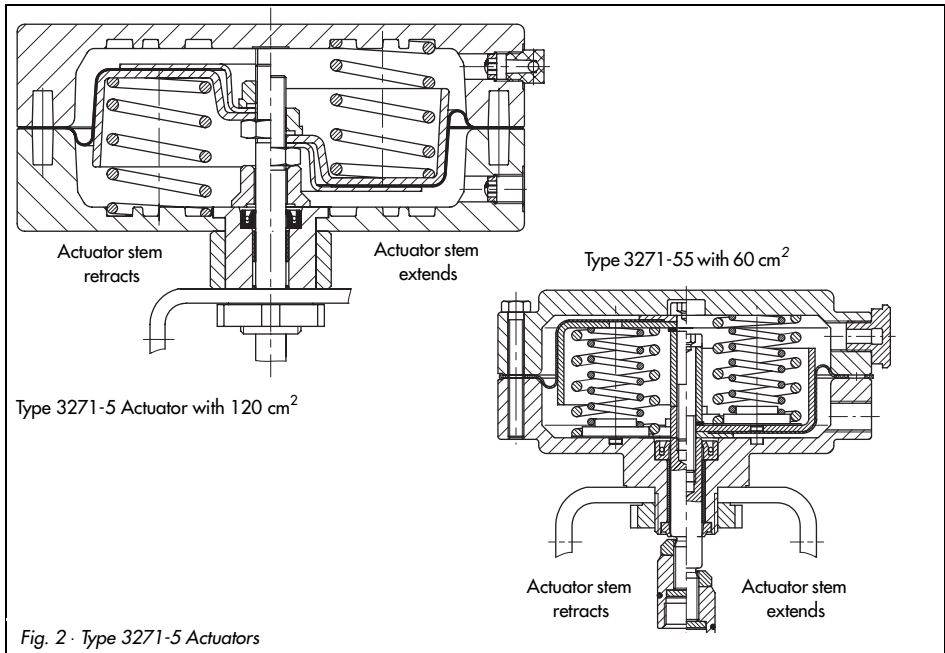

Fig. 2 · Type 3271-5 Actuators

Actuator stem extends:

When the signal pressure is reduced or in case of a supply air failure, the springs move the actuator stem downwards and close the valve. The valve is opened against the spring force, when the signal pressure increases.

Actuator stem retracts:

When the signal pressure is reduced or in case of a supply air failure, the springs move the actuator stem upwards and open the valve. The valve is closed against the spring force, when the signal pressure increases.

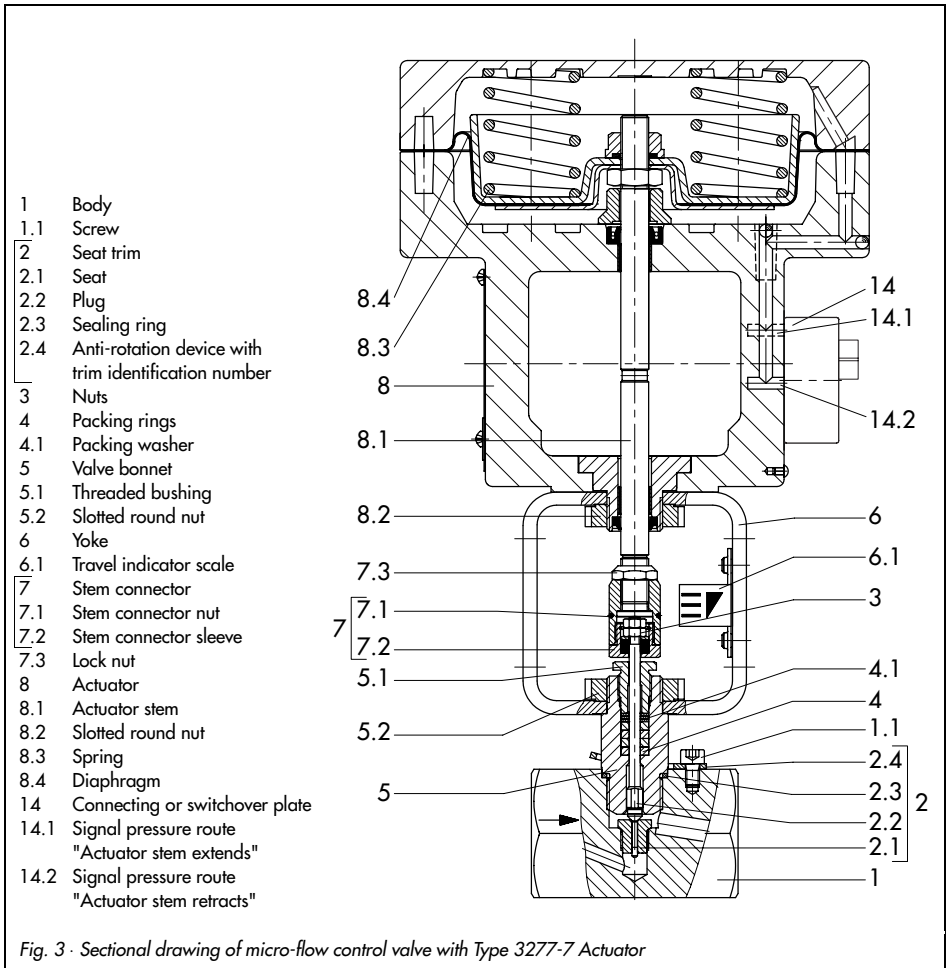

Fig. 3 - Sectional drawing of micro-flow control valve with Type 3277-7 Actuator

2 Assembling and adjusting valve and actuator

If control valve and actuator have not been pre-assembled by the manufacturer, observe the different signal pressure connections of the actuators on assembly.

2.1 Signal pressure connection

Type 3510-1 Control Valve

with Type 3271-5 Actuator

- ▶ The signal pressure connection for fail-safe action "Actuator stem extends" is located at the bottom of the diaphragm case. For "Actuator stem retracts", the connection is to be found at the top of the diaphragm case.

Type 3510-7 Control Valve

with Type 3277-5 Actuator

Actuator with positioner:

The signal pressure is transferred to the diaphragm case via bores at the left and right side of the yoke and via a **switchover plate** (accessories). The fail-safe action "Actuator stem extends" or "Actuator stem retracts" determines how the switchover plate needs to be aligned to the mark.

- ▶ Turn the switchover plate, so that the appropriate symbol for the fail-safe action is aligned to the mark.

Whether the actuator is attached to the left or right depends on the operating direction (>>) or (<<) of the positioner.

Actuator without positioner:

Instead of a switchover plate, a **connecting plate** (accessories) is required if the actuator is used without positioner

Here, the signal pressure is transferred to the diaphragm case directly via the signal pressure connection of the connecting plate.

- ▶ Turn the connecting plate, so that the appropriate symbol for the fail-safe action "Actuator stem extends" or "Actuator stem retracts" is aligned to the mark.
- ▶ Make absolutely sure that the gasket of the connecting plate is inserted correctly.
- ▶ The connecting plate provides bores for NPT and G threads. Seal the unused connection with a rubber gasket and a square plug.

Accessories:

Switchover plate and connecting plate need to be ordered as accessories.

Note that actuators with device modification index **01**, e.g. 3277-531xxx20.**01** (old = .00) must be equipped with new plates. Old and new plates are not interchangeable.

Switchover plate **new Order no. 1400-6822**
old Order no. 1400-6819

Connecting plate **new Order no. 1400-6823**
old G thread Order no. 1400-6820
old NPT thread Order no. 1400-6821

Note!

When used in connection with the micro-flow valve, the pneumatic actuators with fail-safe action "**Actuator stem retracts**" are limited to the max. permissible supply pressures [bar] listed in the table.

For actuators with fail-safe action "**Actuator stem extends**", the max. supply pressure is limited to 4 bar.

Valves with positioners are to be adjusted to these max. perm. supply pressures.

Signal pressure range	Adjusted to	Max. perm. pressure
0.2 to 1	0.4 to 0.8	2.5
0.4 to 2.0	0.8 to 1.6	3.3
1.4 to 2.3	1.7 to 2.1	3.8
2.1 to 3.3	2.4 to 3.0	4.7

2.2 Assembly and adjustment

For actuators with a switchover plate for attachment of a positioner, a suitable adapter needs to be connected to the bores at the side. Alternatively, the connecting plate (Fig. 4, right) can be used.

1. On the actuator stem, loosely screw both stem connector nut (7.1) and lock nut (7.3) all the way up (Fig. 3).
2. Slide slotted round nut (8.2) over both coupling nut and lock nut.
3. Place the actuator on the yoke (7) and fasten with slotted round nut (8.2). For fail-safe action "Actuator stem extends", apply approx. 50 % of the signal pressure range (see nameplate) to the signal pressure connection of the actuator using a pressure regulator, caus-

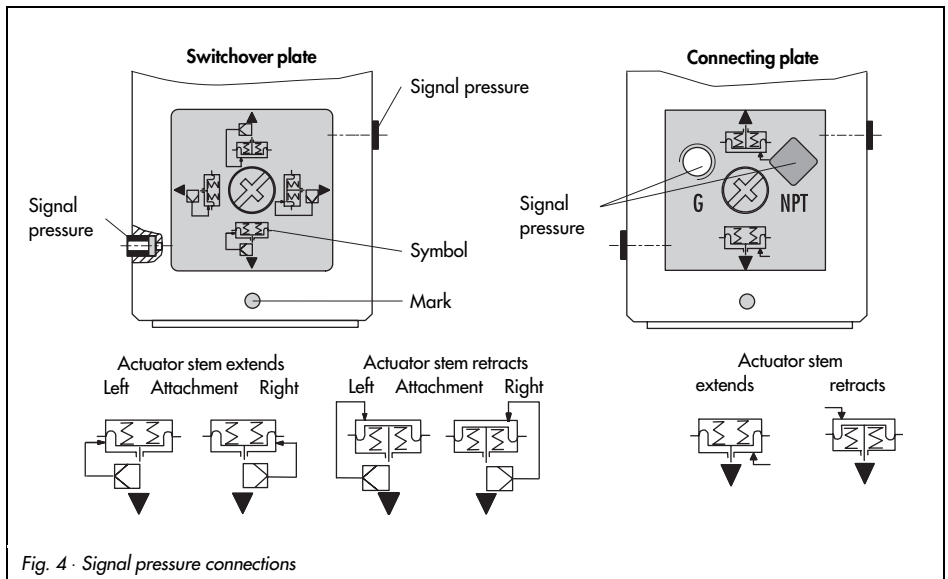

Fig. 4 · Signal pressure connections

ing the actuator stem to retract far enough to screw together stem connector nut (7.1) and stem connector sleeve (7.2).

4. Screw together stem connector sleeve (7.2) and stem connector nut (7.1) as tightly as possible.
5. Apply lower range value of the signal pressure range to the signal pressure connection.
For a signal pressure range (bench range) of, for example, 0.4 to 0.8 bar and an actuator with fail-safe action "Actuator stem extends", the lower signal pressure range value is 0.4 bar; for "Actuator stem retracts" it is 0.8 bar.
6. Rotate stem connector (7) on actuator stem until plug stem moves from the closed position at the corresponding initial value. To do so, change signal pressure each time using the pressure regulator, and return to the initial lower range value.
7. Fasten lock nut (7.3) to secure the stem connector.
8. Align travel indicator scale (6.1) to the black ring on the stem connector.

3 Installation

3.1 Mounting position

Any desired mounting position is possible.

Note! Make sure the valve is installed free of stress. If necessary, support the pipes near the connections.
Flush pipes thoroughly before installing the valve.

For valve versions with bellows seal or insulating section, which are installed in pipes to be insulated, do not insulate the bellows intermediate piece or insulating section (9).

Test connection

The version with metal bellows seal can be equipped with a test connection (16) with G 1/8 thread at the bellows seal. This connection is used to check the tightness of the bellows.

It is recommended to install a suitable leakage indicator, in particular when explosive and hazardous media are used.

4 Operation - Reversing the operating direction

If it becomes necessary to reverse the fail-safe action of the actuator from "Actuator stem extends" to "Actuator stem retracts" or vice versa, refer to the mounting and operating instructions of the actuator for details.

EB 8310 EN for Type 3271-5,
EB 8311 EN for Type 3277-5.

5 Troubleshooting

If the valve leaks, the packing may be defective or, in the bellows version, the metal bellows may be defective.

Tight shut-off of the valve can also be impaired by impurities or other foreign particles between seat and plug, or by damaged seat joints.

Remove the affected components, clean them thoroughly and, if necessary, replace them.



Caution!

Make sure to relieve the pressure from the pressurized part of the plant and, depending on the medium, drain it completely before performing maintenance. For high temperatures, allow the plant to cool down to ambient temperature. Disconnect and shut off the supply air as well as the control signals to prevent against danger posed by moving parts at the valve.

As valves are not free of dead cavities, remember that there might still be residual media in the valve. This particularly applies for valve version with bellows seal or insulating section.

It is recommended to remove the valve from the pipeline for maintenance.

Note!

*The seat and special tools required for installation as well as the appropriate tightening torques are to be found in the **SAM-SON Special tools brochure WA 029**.*

***A complete tool kit** for the Type 3510 Micro-flow Valve can be ordered separately (order no. 1280-3050).*

5.1 Replacing the stuffing box packing

If leakage occurs at the stuffing box, the stuffing box packing must be replaced as described below.

1. For actuators with "Actuator stem extends", apply approx. 50 % of the signal pressure range (see nameplate) to the actuator, causing the actuator stem to retract.
Place socket wrench (width across flats (SW) 17) on stem connector nut (7.1) and unscrew stem connector sleeve (7.2) with a second SW 17 wrench.
2. Unscrew the bottom slotted round nut (5.2). Remove actuator (8) including yoke (6) from the valve, turning the slotted round nut (5.2), so that a groove points towards the travel indicator scale (6.1).
3. Take out the nuts (3). Remove stem connector sleeve (7.2) from the plug stem.
4. Remove the screw (1.1) and the anti-rotation device (2.4). Unscrew the valve bonnet (5) from the valve body.
5. Unscrew threaded bushing (5.1). Pull the plug stem, together with the plug (2.2), out of the valve bonnet (5).
For versions with bellows intermediate piece or insulating section, separate valve bonnet and bellows intermediate piece/insulating section (9). The plug stem extension (10.1, Fig. 6) remains fixed in the extension bonnet.
6. Remove packing washers (4.1) and packing rings (4) from the packing chamber using a suitable tool. Make

sure not to damage the sealing edges.
Clean packing chamber thoroughly.

Assembly:

7. Insert new sealing rings. Start with a white ring, followed by two black rings and another white one. Make sure that the butt joints of successive rings are not positioned on top of each other.
8. Insert packing washer(s) (4.1). Tighten threaded bushing (5.1) manually.
9. Slide plug stem with plug (2.2) into the valve bonnet as far as it will go. Tighten threaded bushing (5.1), observing a minimum gap of 1.3 mm between valve bonnet and threaded bushing. If this is not the case, add required number of **packing washers** (4.1) (min. 1, max. 3 washers).
10. Insert new sealing ring (2.3) into the body. Screw together valve bonnet and body.
11. Place anti-rotation device (2.4) on the valve bonnet and tighten it, so that the fastening screw (1.1) is seated in the oblong hole.
12. Push stem connector sleeve (7.2) onto the plug stem with the thread facing upwards. Screw on nuts (3).
Lock nuts against each other, so that approx. 1 mm of the thread is still visible.
13. Place actuator including yoke onto valve bonnet. Tighten with slotted round nut (5.2).
For actuators with "Actuator stem extends", apply approx. 50 % of the signal pressure range (see nameplate) to the actuator using a pressure regulator, causing the actuator stem to retract far

enough to screw together stem connector nut (7.1) and stem connector sleeve (7.2).

14. Screw together stem connector sleeve (7.2) and stem connector nut (7.1) as tightly as possible. Tighten lock nut (7.3).

15. Check adjustment according to instructions given in section 2.2, items 5 to 8.

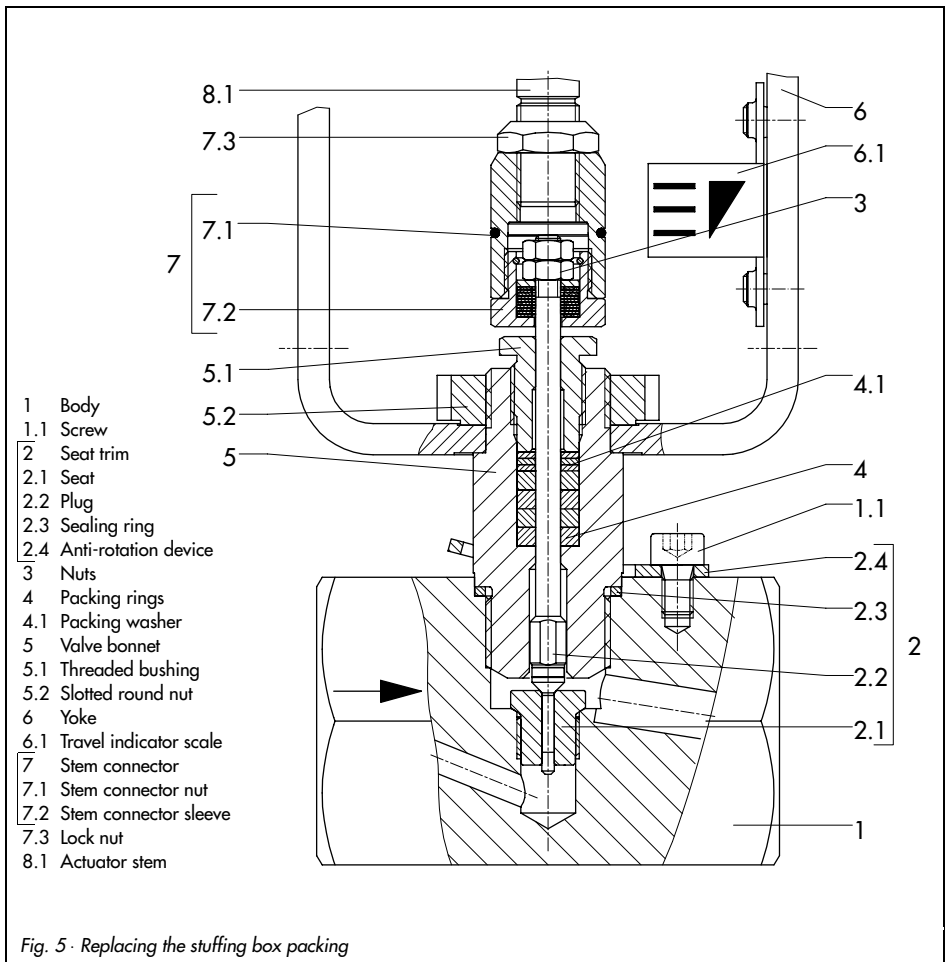

Fig. 5 · Replacing the stuffing box packing

5.2 Replacing seat and plug

Standard version:

- ▶ For assembly/disassembly, proceed as described in section 5.1. Additionally, unscrew the seat (2.1) using a socket wrench.

Important!

If, on replacing the seat trim (parts 2.1 to 2.4), you wish to install a trim with a different K_V value, the old anti-rotation device must also be replaced with the one included in the new trim. On the anti-rotation device as well as on the seat and plug themselves, there is an identification number indicating which trim parts belong together as well as the material, K_V s value and characteristic.

Never combine seats and plugs belonging to different trims!

The seat thread imposes restrictions on replacing trims. Only the K_V values of associated seat threads can be exchanged (see table below).

Table seat thread		
Seat thread	M10 x 1	M16 x 1
K_V s value	0.0001 to 0.4	0.63 to 1.6
PN max.	400	100

Versions with bellows seal or insulating section:

Unscrew valve bonnet (5).

- ▶ In the insulating section version, remove insulating section (9) from the valve body, so that the plug stem including plug (2.2) can be unscrewed from the plug stem extension (10.1).
- ▶ In the metal bellows version, unscrew bellows seal (10) together with plug stem extension (10.1) and plug (2.2) from the bellows intermediate piece (9) using a bellows nut wrench.
Unscrew plug stem including plug from the plug stem extension and remove bellows intermediate piece from valve body.

Before reassembling, replace sealing rings (9.1 and 9.2). In addition, secure bellows intermediate piece (9) or insulating section (9) as well as the valve bonnet using additional anti-rotation devices (11 and 12).

The upper anti-rotation devices (2.4 and 12) are secured by the disk (15).

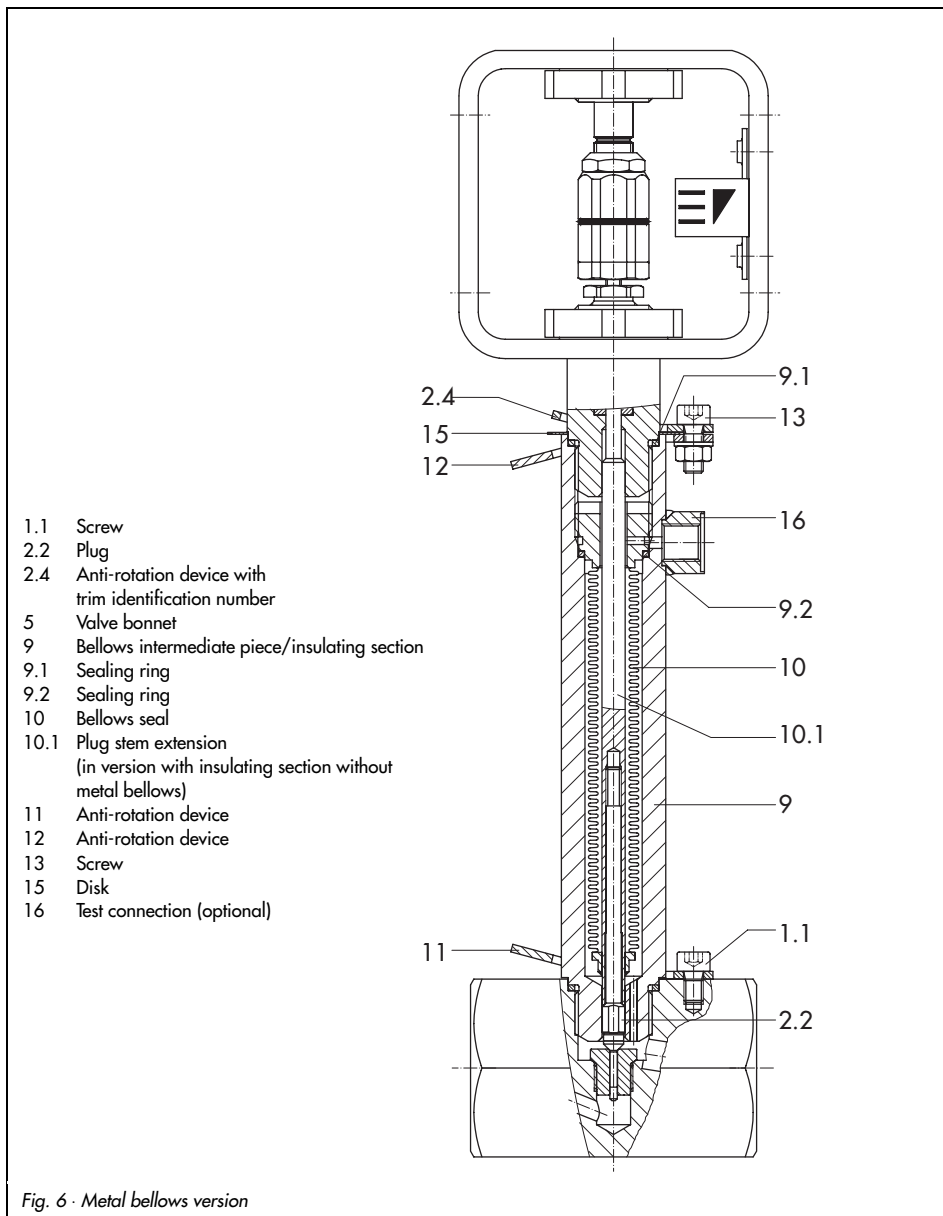

Fig. 6 · Metal bellows version

6 Customer inquiries

Please include the following details in your inquiry:

- ▶ Order number
- ▶ Type, product and identification number
- ▶ Valve style: globe or angle valve
- ▶ Nominal size and pressure of the valve, additionally K_{VS} value and the identification number of the attached trim
- ▶ Pressure, density, viscosity and temperature of the flow medium
- ▶ Flow rate in m^3/h
- ▶ Direction of flow through the valve
- ▶ Bench range (signal pressure range, e.g. 0.2 to 1 bar) of the attached actuator
- ▶ Has a strainer been installed?
- ▶ Installation drawing

For **dimensions and weights** of the valve versions, refer to Data Sheet T 8091 EN.



SAMSON AG · MESS- UND REGELTECHNIK
Weismüllerstraße 3 · 60314 Frankfurt am Main · Germany
Phone: +49 69 4009-0 · Fax: +49 69 4009-1507
Internet: <http://www.samson.de>

EB 8091 EN

S/Z 2002-07