

Pneumatic Actuator Type 3271

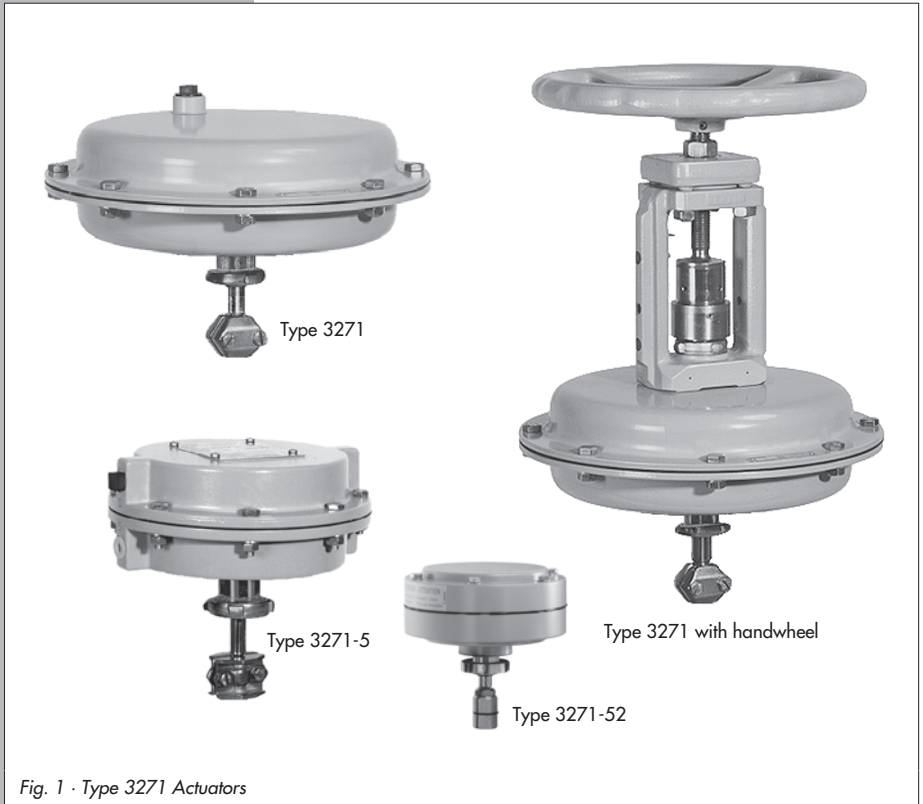

Fig. 1 · Type 3271 Actuators

Mounting and Operating Instructions

EB 8310 EN

Edition October 2004

Contents	Page
1	Design and principle of operation 3
2	Operation 6
2.1	Reversing the operating direction (fail-safe action) 6
2.1.1	Type 3271 6
2.1.2	Actuator with handwheel 8
2.2	Replacing the diaphragm and stem seal 10
2.3	Adjusting the travel stop 11
2.4	Manual operation of Type 3271 with side-mounted handwheel 12
2.4.1	Normal operation with the handwheel locked 12
2.4.2	Actuator stem extends upon air supply failure 12
2.4.3	Actuator stem retracts upon air supply failure. 12
2.4.4	Actuator stem extends when supply air is applied. 13
2.4.5	Actuator stem retracts when supply air is applied 13
3	Description of nameplate 14
4	Customer inquiries 15

General safety instructions



- ▶ *Assembly, start-up and operation of the device may only be performed by trained and experienced personnel familiar with this product. According to these mounting and operating instructions, trained personnel is referred to individuals who are able to judge the work they are assigned to and recognize possible hazards due to their specialized training, their knowledge and experience as well as their knowledge of the relevant standards.*
- ▶ *Any hazards which could be caused by the signal pressure and moving parts of the actuator are to be prevented by means of appropriate measures.*
- ▶ *Proper shipping and appropriate storage are assumed.*

1 Design and principle of operation

The **Type 3271** Actuators are primarily used for attachment to Series 240, 250, 260 and 280 Valves.

Type 3271-5 with a die-cast aluminum casing and effective diaphragm areas of 60 and 120 cm², is mounted to Type 3510 Valves and Series 240 Valves.

The Type 3271 Actuator is made up of two diaphragm cases, a rolling diaphragm and springs.

Actuators with manual override additionally

have a handwheel mounted on the top diaphragm case or mounted on the side of the valve yoke. The handwheel moves the actuator stem over a spindle. The Type 3271 Actuator can be equipped in a special version with a mechanically adjustable travel stop (Fig. 7).

The signal pressure creates a force at the diaphragm surface which is balanced by the springs (6) arranged in the actuator. The number of springs and their compression determine the bench range (signal pressure range) while taking the rated travel into account which is directly proportional to the signal pressure.

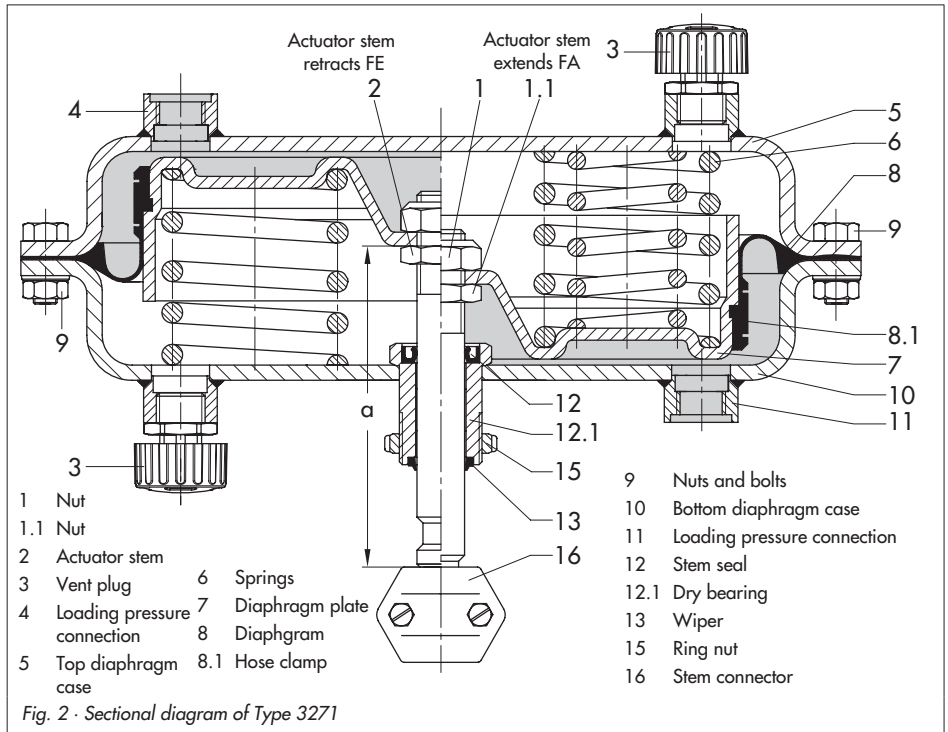

Design and principle of operation

A maximum of 30 springs can be installed, partly fitted inside one another.

In an actuator with the fail-safe action "Actuator stem extends FA", the loading pressure is connected to the loading pressure connection (11) to fill the bottom diaphragm chamber with air which causes the actuator stem to move upwards.

In an actuator with the fail-safe action "Actuator stem retracts FE", the loading pressure is connected to the loading pres-

sure connection (4) to fill the top diaphragm chamber with air which causes the actuator stem to move downwards.

The stem connector (16) connects the actuator stem (2) to the plug stem of the valve.

Fail-safe action

When the signal pressure fails, the fail-safe action of the actuator depends on whether the springs are installed in the top or bottom diaphragm chamber.

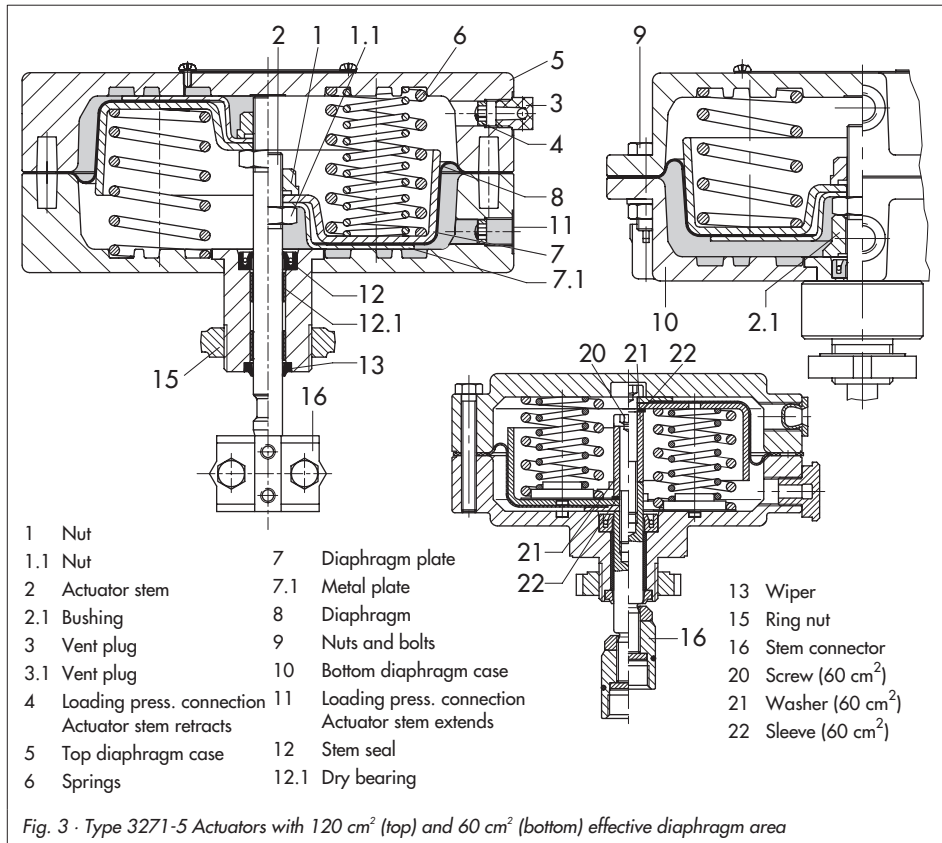

Actuator stem extends

When the signal pressure is reduced or the air supply fails, the springs move the actuator stem downwards and close the valve.

The valve opens when the signal pressure is increased enough to overcome the force exerted by the springs.

Actuator stem retracts

When the signal pressure is reduced or the air supply fails, the springs move the actuator stem upwards and open the valve. The valve closes when the signal pressure is in-

creased enough to overcome the force exerted by the springs.

The **tandem actuator** (Fig. 4) has two diaphragms connected to each other. The signal pressure produces an actuating force double to that of an actuator with just one diaphragm.

Actuators with an **additional manual override** (Fig. 5) have a handwheel that moves the actuator stem over a spindle after the locking mechanism (lock nut) has been disengaged. A side-mounted handwheel (Fig. 8) moves the stem over a bevel or worm gear.

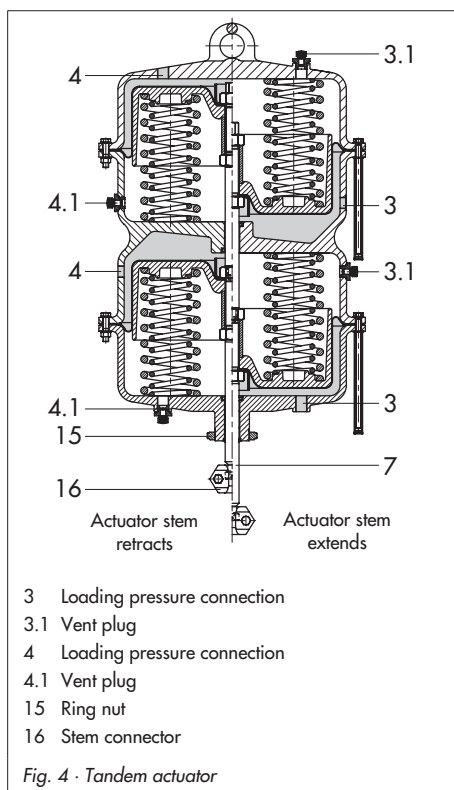

Note!

Refer to the attached valve's Mounting and Operating Instructions to mount or remove the actuator from the valve.

Actuators with 2800 cm² diaphragm area weigh 450 kg and cannot be mounted onto the valve on site.

Important!

The pneumatic actuators are designed for a maximum supply pressure of 6 bar.

To prevent the actuator from being damaged, do not let the supply pressure exceed the upper spring range value by more than 3 bar when the actuator is used for flow-switching service (on-off valve) with the fail-safe action "Actuator stem retracts".

Label actuators that have a reduced supply pressure with a sticker "max. supply pressure limited to ... bar".

The maximum supply pressure for actuators with fail-safe action "Actuator stem extends" and mechanical travel stops should not exceed the upper spring range value by more than 1.5 bar.

2 Operation

Note! Only apply the loading pressure to the diaphragm chamber that does not contain the springs. It is important for a troublefree operation of the actuator that the vent plug (3) is not blocked. Make sure in versions with a handwheel that the plug stem can move freely when the valve is being positioned by the pneumatic actuator by moving the handwheel into a neutral position (Fig. 5 for 240 to 700 cm² and Fig. 8 for 1400 and 2800 cm²).

2.1 Reversing the operating direction (fail-safe action)

The operating direction, i.e. fail-safe action, of pneumatic actuators can be changed. Prior to proceeding, you must remove the actuator from the valve.

The fail-safe action "Actuator stem extends" or "Actuator stem retracts" is specified on the nameplate with the initials FA and FE on Type 3271 Actuator or by a symbol on Type 3271-5 Actuator.



Caution!

To disassemble an actuator with preloaded actuator springs (recognizable by the long bolts on the diaphragm chambers), always undo the short bolts first and then unthread the long bolts slowly and evenly until the actuator springs are fully decompressed.

2.1.1 Type 3271

Reversing the fail-safe action "Actuator stem extends" to "Actuator stem retracts" (Fig. 2)

1. Unthread nuts and remove the bolts (9) from the diaphragm cases.
2. Lift off the top diaphragm case (5) and remove the springs (6).
3. Pull the actuator stem (2) with diaphragm plate (7) and diaphragm (8) out of the bottom diaphragm case (10).
4. Unscrew nut (1), while holding the nut (1.1) stationary with a suitable tool.

Caution! Proceed carefully to avoid damaging the seals of the actuator stem.

Caution!

Do not loosen the nut (1.1) on the actuator stem. It is painted over to protect it. If, however, it does become loose, it is essential that the dimension "a" from the top of the nut to the bottom of the actuator stem is kept as shown in Fig. 2 and the table below.

Actuator cm ²	Dimension a in mm (Fig. 2)
120	100.5, or 89 with threaded end
240	98.25
350	107.25
700	125 for 15 mm rated travel (0.4-1.2 bar) 144 for 30 mm and 40 mm rated travel
1400	230
2800	430

5. Lift off the diaphragm plate with diaphragm and replace them in reverse order. Tighten nut (1).
6. Apply lubricant/sealant (order no. 8152-0043) to the actuator stem.
7. Place the diaphragm plate with diaphragm in the top diaphragm case. Insert the springs (6) and slide the lower diaphragm case over the actuator stem.
8. Screw tight the nuts and bolts of the diaphragm cases.
9. Remove vent plug (3) from top diaphragm case and screw it into the loading pressure connection on the bottom diaphragm case.

The actuator springs now press against the diaphragm plate from below and cause the actuator stem to retract. The loading pressure is connected over the connection (4) to the top diaphragm chamber. The actuator stem starts to extend when the signal pressure overcomes the force of the springs.

10. Record the changed fail-safe action on the nameplate!

Proceed in the same manner for the **Type 3271-5 Actuator**, but additionally install the metal plate (7.1).

For the version intended for attachment to micro-flow valves, additionally install the bushing (2.1) for the mechanical travel stop. In Type 3271-52 Actuator with 60 cm² diaphragm area, unthread the screw (20) and then remove the washer (21) and sleeve (22).

Reversing the fail-safe action "Actuator stem retracts" to "Actuator stem extends" (Fig. 2)

1. Unthread nuts and remove the bolts (9) and lift off the top diaphragm case (5).
2. Pull the diaphragm plate (7) and diaphragm with the actuator stem (2) out of the bottom diaphragm case (10). Remove the springs (6).
3. Unscrew nut (1), while holding the nut (1.1) stationary with a suitable tool.
Caution! Proceed carefully to avoid damaging the seals of the actuator stem.
4. Remove the diaphragm plate with diaphragm and replace them in reverse order. Screw tight nut (1).
5. Coat the actuator stem with sealant/lubricant (order no. 8152-0043) and insert it into the bottom diaphragm chamber along with the diaphragm plate and diaphragm.
6. Insert springs (6) and place the top diaphragm case back on.
7. Screw tight the nuts and bolts of the diaphragm cases.
8. Remove the vent plug (3) from the bottom loading pressure connection and place it in the top connection.

The springs which are now pressed from the top against the diaphragm plate cause the actuator stem to extend.

The signal pressure is connected via the connection (11) to the bottom diaphragm chamber. The actuator stem starts to retract when the signal pressure overcomes the force of the springs.

- Record the changed fail-safe action on the nameplate!

Proceed in the same manner for the **Type 3271-5 Actuator**, but additionally install the metal plate (7.1).

For an actuator intended for a micro-flow valve, install the bushing (2.1) for the travel stop.

For Type 3271-52 Actuator with 60 cm² undo the screw (20) and then remove the washer (21) and sleeve (22).

2.1.2 Actuator with handwheel

240, 350 and 700 cm² (Fig. 5) only

- Undo lock nut (20) and relieve the springs (6) by turning the handwheel (17).
- Loosen threaded pin (26) and unscrew coupling nut (25) from the coupling (22).
- Knock out the clamping sleeve (23) and remove the ring (24).
- Unthread the ring nut (28) and lift off the flange part (21).

Reversing the fail-safe action "Actuator stem extends" to "Actuator stem retracts"

- ▶ Proceed as described in section 2.1.1. However, use the word "spindle with nut (27)" in place of "nut (1)".

After reversing the operating direction:

- Place the flange part (21) and coupling nut (25). Then fasten the flange part (21) with the ring nut (28).
- Attach the ring (24) with clamping sleeve (23).
- Screw coupling nut (25) as far as it will go onto the coupling (22) and secure with threaded pins (26).

Reversing the fail-safe action "Actuator stem retracts" to "Actuator stem extends"

- ▶ Proceed as described in section 2.1.1. However, use the word "spindle with nut (27)" in place of "nut (1)".

After reversing the operating direction:

1. Place the flange part (21) and the coupling nut (25) and then secure flange part (21) with ring nut (28).
2. Attach the ring (24) with clamping sleeve (23).
3. Screw coupling nut (25) as far as it will go onto the coupling (22) and secure with threaded pins (26).

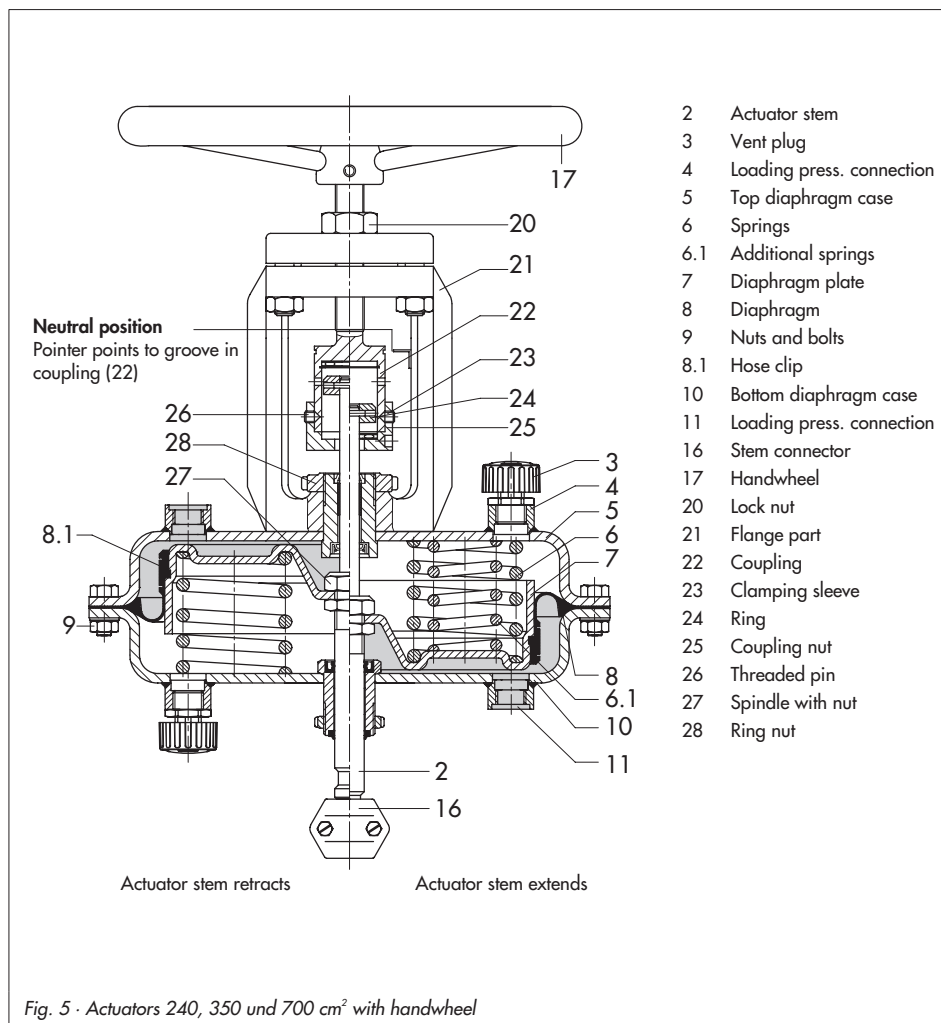

Fig. 5 · Actuators 240, 350 und 700 cm² with handwheel

2.2 Replacing the diaphragm and stem seal

Diaphragm (Fig. 2)

1. Remove the diaphragm plate (7) together with diaphragm (8) and actuator stem (2) from the diaphragm case as described in section 2.1.
2. Remove the hose clamp (8.1) and pull it together with the diaphragm (8) off the diaphragm plate (7) (not necessary with Type 3271-5 as the diaphragm is held in place by the metal plate (7.1)).
3. Stretch the new diaphragm onto the diaphragm plate. Fit the hose clamp (8.1) evenly into the groove intended for it and tighten. Insert a piece of protective wear-resistant rubber between the diaphragm and the worm screw of the hose clamp (jubilee clip) to protect the diaphragm.
4. Reassemble actuator as described in section 2.1.

Stem seal (Fig. 6)

1. Remove the diaphragm plate (7) together with the actuator stem (2) from the diaphragm case as described in section 2.1.
2. Coat the new stem seal (12) with lubricant/sealant (order no. 8152-0043) and insert it.
3. If necessary, replace the dry bearing (12.1) and wiper (13) with new ones as well.
4. Reassemble the actuator as described in section 2.1.

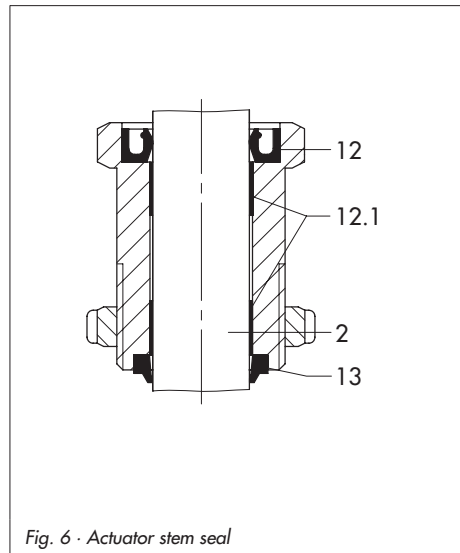

Fig. 6 · Actuator stem seal

2.3 Adjusting the travel stop

(Type 3271 in special version only)

The travel stop can be adjusted upwards or downwards to 50 % of the travel.

Downward travel stop

(actuator stem extends)

1. Undo the lock nut (34) and unscrew the cap (33).
2. Undo the lock nut (31) and adjust the nut (32) to set required travel stop.
3. Tighten the lock nut (31) again.

Upward travel stop

(actuator stem retracts)

1. Undo the lock nut (34) and adjust the cap (33) to set the required travel stop.
2. Tighten the lock nut (34) again.

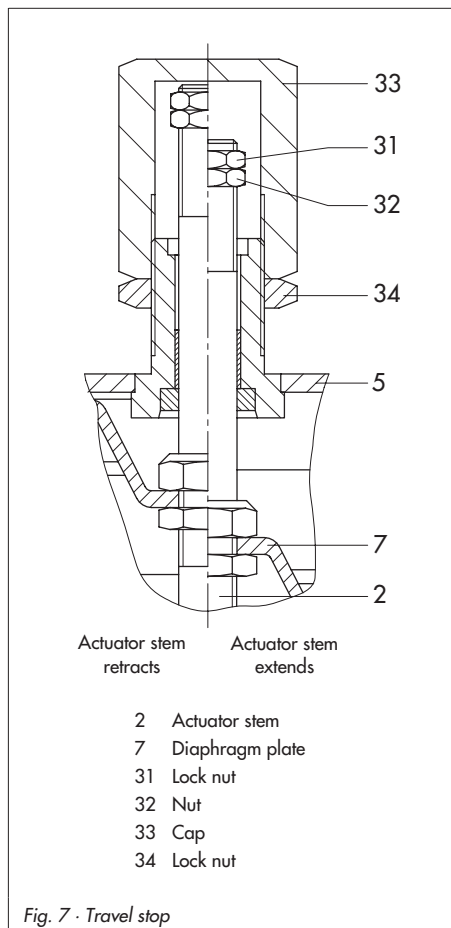

2.4 Manual operation of Type 3271 with side-mounted handwheel

Note! To operate the handwheel on actuators with 1400 and 2800 cm² diaphragm areas, do not use any additional tools such as a lever or wrench.

2.4.1 Normal operation with the handwheel locked

The handwheel is not used. The valve is positioned by the pneumatic signal pressure applied to the valve.

To achieve this, the pin next to the actuator stem must be in the **neutral position**:

The pin must sink into the flange so far that its groove is aligned with the top of the flange.

If this is not case:

- ▶ Pull the locking knob on the side all the way out and turn it to unlock the handwheel.
- ▶ Turn the handwheel until the pin reaches the neutral position.
- ▶ Turn the locking knob until it engages to lock the handwheel again.

The easiest way to adjust the handwheel is with the valve in the fail-safe position.

2.4.2 Actuator stem extends upon air supply failure

The manual override must overcome the force of the actuator springs to open the valve.

- ▶ Pull the locking knob on the side all the way out and turn it to unlock the handwheel.
- ▶ Turn the handwheel counterclockwise (direction Auf/Open/Ouvert), the pin sinks into the flange. Initially, the handwheel is easy to turn and after a certain point of pressure is reached, the valve starts to open.
- ▶ On reaching the final position at the stop, do not turn the handwheel any further by force.
 - Caution!** Risk of damage.
- ▶ After finishing manual operation, turn the handwheel to bring the pin back into the neutral position again.
- ▶ Turn the locking knob until it engages to lock the handwheel again.

2.4.3 Actuator stem retracts upon air supply failure

The manual override must overcome the force of the actuator springs to close the valve.

- ▶ Pull the locking knob on the side all the way out and turn it to unlock the handwheel.
- ▶ Turn the handwheel clockwise (direction Zu/Close/Fermé), the pin emerges from the flange. Initially, the handwheel is easy to turn and after a certain point of pressure is reached, the valve starts to close.
- ▶ On reaching the final position at the stop, do not turn the handwheel any further by force.
 - Caution!** Risk of damage.

- ▶ After finishing manual operation, turn the handwheel to bring the pin back into the neutral position again.
- ▶ Turn the locking knob until it engages to lock the handwheel again.

2.4.4 Actuator stem extends when supply air is applied

The manual override must overcome the force of the actuator springs to open the valve.

Do not close the valve any further than before unlocking the handwheel.

- ▶ Pull the locking knob on the side all the way out and turn it to unlock the handwheel.
- ▶ Turn the handwheel counterclockwise (direction Auf/ Open/Ouvert), the pin sinks into the flange. Initially, the handwheel is easy to turn and the pin's position does not move anymore. After a certain point of pressure is reached (how long depends on the valve travel), the valve starts to open.

- ▶ On reaching the final position at the stop, do not turn the handwheel any further by force.

Caution! Risk of damage.

- ▶ After finishing manual operation, turn the handwheel to bring the pin back into the neutral position again.
- ▶ Turn the locking knob until it engages to lock the handwheel again.

2.4.5 Actuator stem retracts when supply air is applied

The manual override must overcome the force of the actuator springs to close the valve.

Do not open the valve any further than before unlocking the handwheel.

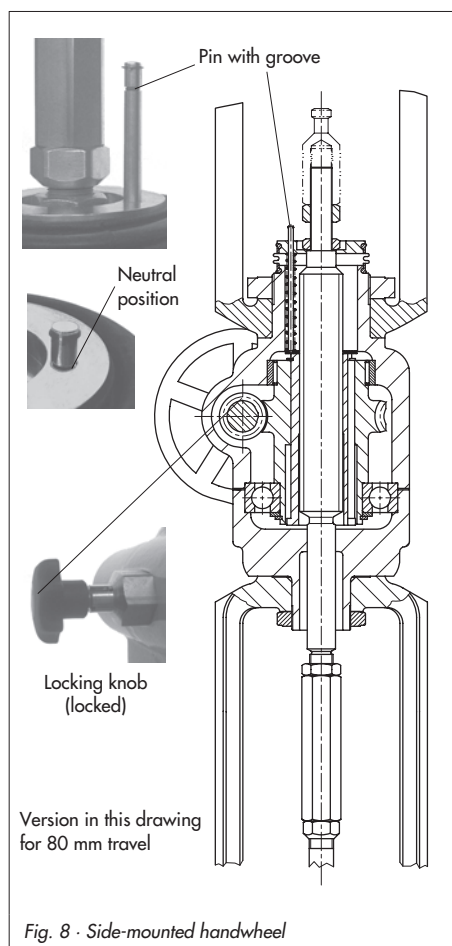

- ▶ Pull the locking knob on the side all the way out and turn it to unlock the handwheel.
- ▶ Turn the handwheel clockwise (direction Zu/Close/Fermé), the pin emerges from the flange.

After a certain point of pressure is reached, the valve starts to close.

- ▶ On reaching the final position at the stop, do not turn the handwheel any further by force.

Caution! Risk of damage.

- ▶ After finishing manual operation, turn the handwheel to bring the pin back into the neutral position again.
- ▶ Turn the locking knob until it engages to lock the handwheel again.

3 Description of nameplate

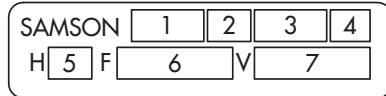

- 1 Type designation
- 2 Modification index
- 3 Effective diaphragm area
- 4 Operating direction:
Actuator stem extends FA
Actuator stem retracts FE
- 5 Travel
- 6 Bench range (spring range)
- 7 Bench range with preloaded springs

Fig. 9 · Nameplate

4 Customer inquiries

Please specify the following details on making inquiries:

- ▶ Type and model number
- ▶ Effective diaphragm area
- ▶ Bench range (spring range) in bar
- ▶ Actuator version and its operating direction

Dimensions and weights

Refer to the Data Sheets T 8310-1 EN or T 8310-2 EN for the different actuator versions.



SAMSON AG · MESS- UND REGELTECHNIK
Weismüllerstraße 3 · 60314 Frankfurt am Main · Germany
Phone +49 69 4009-0 · Fax +49 69 4009-1507
Internet: <http://www.samson.de>

EB 8310 EN

S/Z 2004-11