

Electrohydraulic Actuator Type 3274



Fig. 1 · Type 3274

Mounting and Operating Instructions

EB 8340 EN

Edition June 2001



Contents		Page
	Safety instructions	3
	Technical data	4
1.	Design and principle of operation	5
1.1	Versions	5
1.2	Principle of operation	6
1.3	Additional electric equipment	6
2.	Installation	8
2.1	Assembly of actuator and valve	8
3.	Electrical connections	10
4.	Operation	12
4.1	Manual operation of the actuator	12
4.1.1	Version with electric override	12
4.1.2	Version with manual override	14
4.2	Adjusting additional electric equipment	14
4.2.1	Positioner	14
4.2.2	Position transmitter	17
4.2.3	Potentiometer	18
4.2.4	Limit switches	18
5.	Dimensions in mm	19



- ▶ *Assembly, start-up and operation of the device may only be performed by trained and experienced personnel familiar with this product. According to these mounting and operating instructions, trained personnel refers to individuals who are able to judge the work they are assigned to and recognize possible hazards due to their specialized training, their knowledge and experience as well as their knowledge of the applicable standards.*
- ▶ *Any hazards which could be caused by the process medium, the signal pressure and moving parts of the control valve are to be prevented by means of appropriate measures.*
- ▶ *Proper shipping and appropriate storage are assumed.*
- ▶ *The actuators are designed for use in electrical power installations. For wiring and maintenance, you are required to observe the relevant safety regulations. Only use power interruption devices which are protected against unintentional reconnection of the power supply.*
- ▶ *Take special care when making adjustments on live parts. Do not remove any covers!*

Technical data

Actuator		Type	3274	-11	-12	-13	-14	-15	-16	-17	-18	-21	-22	-23	
Manual override			Electric					Mechanical				Electric			
Fail-safe action			Without									With			
Operating direction												OUT	IN	OUT	
Rated travel			15 or 30 mm												
Nominal transit time ¹⁾			60 s for 15 mm, 120 s for 30 mm, depending on temperature and required thrust												
Positioning rate for fail-safe action mm/s ¹⁾			—									Standard	1	1	1.3
												Optional	3.3	3.3	5
Thrust	Travel 15 mm	When stem moves:	IN	2100	500	4300	500	2100	500	4300	500	2100	1800	500	
			OUT	2000	3400	4300	7700	2000	3400	4300	7700	2000	2300	3400	
N	Travel 30 mm		IN	2100	500	4300	500	2100	500	4300	500	2100	1800	500	
			OUT	1800	3000	4300	7300	1800	3000	4300	7300	1800	2100	3000	
Power supply			230 V, 110 V and 24 V, 50 or 60 Hz (±10 %)												
Power consumption			Min. 80 VA / max. 155 VA ²⁾												
Permissible ambient temperature			-10 to +60 °C (with heating: -35 to +60 °C)												
Permissible storage temperature			-25 to +70 °C												
Degree of protection			IP 65												
Weight			12				13				12				
Motor electronics			Radio interference level acc. to DIN VDE 0857												
Additional electric equipment															
Electric positioner			Supply same as power supply												
Control signal			4 to 20 mA, 0 to 20 mA (R _i = 50 Ω), 0 to 10 V DC, 2 to 10 V DC (R _i = 10 Ω)												
Zero shift			0 to 100 %												
Change of range			30 to 100 %												
Output (feedback)			4 (0) to 20 mA, R = ≤200 Ω; 0 (2) to 10 V, R = ≤2 kΩ												
Hysteresis			Approx. 3 %												
Potentiometer			0 to 1000 Ω, 0 to 200 Ω, 0 to 100 Ω, 0 to 275 Ω, 0 to 138 Ω (for rated travel, 80 % of the final value); perm. load 0.5 W												
Electric limit switch			Maximum of three separately adjustable double-throw contacts, max. 250 V AC, 5 A												
Inductive limit switch			Proximity switch SJ 2-N (normally closed contact only)												
Control circuit			Rating according to the isolating switch amplifier used												
Heating			Approx. 45 W On: < -10 °C, off: > 0 °C above installed thermostats												
Materials															
Case, cover	Cylinder	Piston	Piston rod	Actuator stem	Hydraulic oil										
Die-cast aluminum	Hydraulic cylinder tube	Steel/NBR combination	C 45, hard chromium plating	1.4104	Special HPL, silicone free										

¹⁾ Other values on request ²⁾ Depending on the version, up to 200 VA at high speeds and when heating is on

1. Design and principle of operation

The electrohydraulic actuators are especially suitable for attachment to control valves of the Series 240, 250 and 280, etc. The actuators are connected to the valve bonnet via ring nut. The actuator and plug stem are tightly connected by a stem connector. The actuator essentially consists of the actuator housing, the motor including oil pump as well as the cylinder housing plus piston.

Pilot valves control the supply and discharge of the compressed oil at the piston. The actuator is equipped with compression springs which determine the positioning forces. Actuator versions with spring mechanism also serve to ensure the fail-safe position of the valve in the operating direction "Actuator stem retracts or extends" in case the power supply fails.

1.1 Versions

The following versions are available for different applications:

Versions with electric override

Type 3274-11 · Electrohydraulic actuator with a nominal thrust F_{IN} of 2100 N for operating direction "Actuator stem retracts" and a nominal thrust F_{OUT} of 1800 N for operating direction "Actuator stem extends".

Type 3274-12 · Electrohydraulic actuator with F_{IN} of 500 N and F_{OUT} of 3000 N.

Type 3274-13 · Electrohydraulic actuator with F_{IN} and F_{OUT} of 4300 N each.

Type 3274-14 · Electrohydraulic actuator with F_{IN} of 500 N and F_{OUT} of 7300 N.

Versions with mechanical override

With these versions, the electric override is replaced with a mechanical version.

Type 3274-15 · Electrohydraulic actuator with thrusts as for Type 3274-11.

Type 3274-16 · Electrohydraulic actuator with thrusts as for Type 3274-12.

Type 3274-17 · Electrohydraulic actuator with thrusts as for Type 3274-13.

Type 3274-18 · Electrohydraulic actuator with thrusts as for Type 3274-14.

Versions with fail-safe action and electric override

Type 3274-21 · Electrohydraulic actuator with a nominal thrust F_{IN} of 2100 N and F_{OUT} of 1800 N. Fail-safe action "Actuator stem extends".

Type 3274-22 · Electrohydraulic actuator with a nominal thrust F_{IN} of 1800 N and F_{OUT} of 2100 N. Fail-safe action "Actuator stem retracts".

Type 3274-23 · Electrohydraulic actuator with a nominal thrust F_{IN} of 500 N and F_{OUT} of 3000 N. Fail-safe action "Actuator stem extends".

Typetesting

The Type 3274-21 and 3274-23 Actuators are typetested with different SAMSON valves according to TÜV. See name plate for the DIN register number.

1.2 Principle of operation

The pressure-tight actuator housing (1, Fig. 2 on page 7) also serves as an oil reservoir and incorporates the cylinder housing (2), cylinder (5.1) and piston (5.2), motor (6.1), pump (6.2) and solenoid pilot valves (6.4). The motor (6.1) driven by the oil pump (6.2) feeds compressed oil to the corresponding cylinder chamber via the check valve (6.3) and pilot valve (6.4). In the de-energized state, the solenoid valves are closed. They open when the controller issues a signal. When reaching final positions, or external forces cause the nominal force of the actuator to be exceeded, the motor is deactivated.

Depending on the version, the actuators are equipped with or without one or two compression springs (5.7, 5.8). With Types 3274-11, -12, -15, -16 and -21 to -23, the motor moves the actuator stem in only one direction. The stem is then retracted by the tension of the compression spring. Actuators with electric override have two pushbuttons to open or close the valve.

Actuators with mechanical override are additionally equipped with a gear case. An externally mounted hexagon nut is used to operate the mechanical override. The release button on the top of the actuator serves to either open or close the control valve.

Versions with fail-safe action are equipped with a spring return mechanism and an additional safety solenoid valve which opens when the power supply is interrupted, thus reducing the oil pressure in the cylinder chamber. This mechanism moves the valve plug to the fail-safe position. The operating direction "Actuator stem extends or re-

tracts", depends on the spring arrangement in the actuator.

1.3 Additional electric equipment

All additional electric equipment is located in the terminal box (3). A rack-and-pinion gear converts the linear travel of the actuator stem into a rotary motion which is picked off at the shaft to operate the switching and signaling elements. This additional electric equipment can be retrofitted. The maximum equipment configuration is shown in the table "Additional equipment" in section 4.2.

Electric positioners

Electric positioners compare the output signal of either 4(0) to 20 mA or 0(2) to 10 V from an electric controller with the position of a potentiometer (proportional to the travel of the control valve) and produce a three-point stepping signal.

Electric position transmitters

In the version with three-point stepping signal, an 0(4) to 20 mA or 0(2) to 10 V output signal is generated proportional to the travel of the valve using a 0 to 1000 Ω potentiometer.

Potentiometers

The actuators can be equipped with two potentiometers. A gear segment is driven by a shaft. An easily adjustable transmission mechanism including a twin pinion ensures that the angle of rotation of 260° remains the same for rated travels of 15 and 30 mm.

Electric limit switches

The actuators can be equipped with a maximum of three overrideable electric limit switches on request. They are actuated via infinitely adjustable cams.

The motor is switched off with force-dependent, fixed switches located in the actuator case (1).

Actuators with spring return mechanism only contain one force-dependent switch, since the springs (5.7 and 5.8) determine the other end position.

Priority circuit

The positioner version is equipped with a priority circuit at terminals 82 and 83 (see section 4.2.1).

Heating

For lower ambient temperature ranges, the oil reservoir can be equipped with a heating by the manufacturer. It is activated via thermostats when the oil temperature falls below $-10\text{ }^{\circ}\text{C}$ and deactivated when the oil reaches a temperature of $> 0\text{ }^{\circ}\text{C}$.

The electrical connection is established via N and L.

The heating is not protected by an internal fuse.

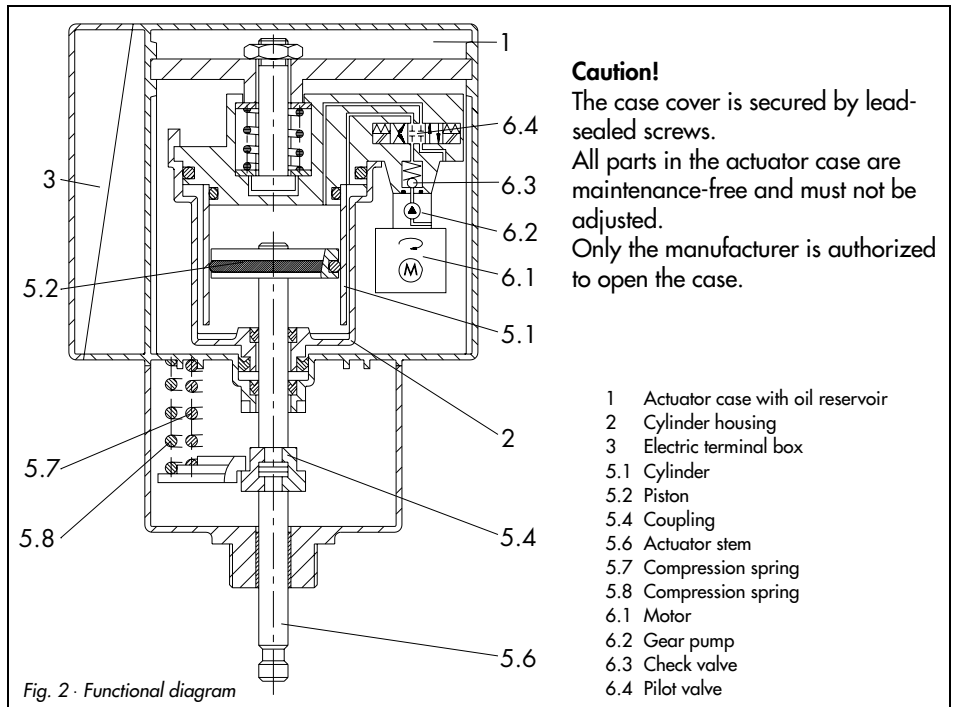

2. Installation

Mounting position: To meet the mounting requirements of actuators with heating and/or manual override, the following mounting positions should be observed.

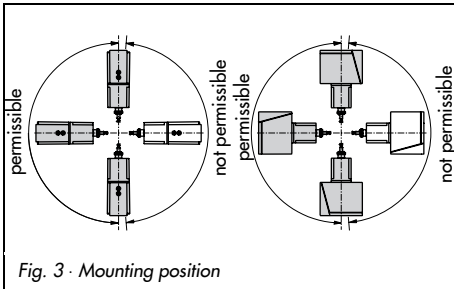

Fig. 3 · Mounting position

The installation of the actuator also depends on the mounting position of the control valve used (see the associated mounting and operating instructions).

For valve sizes DN 100 or above, install the actuator vertically upright to facilitate any maintenance required.

Always observe minimum clearance for removal of the connection cover or the complete actuator (see dimensional drawings, section 5).

2.1 Assembly of actuator and control valve

If valve and actuator have not been pre-assembled prior to delivery, proceed as follows (see Fig. 4):

- ▶ Check whether actuator stem is retracted.
 - For versions with electric override:** connect actuator to power supply (see section 3). Disconnect isolating terminal 81 (see section 4.1) and use pushbutton IN to start to retract the actuator stem.
 - ▶ **For versions with mechanical override:** press button on the top of the actuator case. Then use a hexagonal wrench to operate the rack-and-pinion gear and slowly retract the actuator stem.
 - ▶ For versions with fail-safe action "stem extends", keep the power supply to the actuator connected, otherwise the fail-safe function will extend the actuator stem again.

Valve sizes DN 15 to 80 (Series 240)

1. Replace coupling nut (9.3) with an external \varnothing 10 mm located on the plug stem with a \varnothing 16 mm nut (order no. 0250-0674).
2. After you have replaced the nut (9.3), adjust dimension x to 75 mm with the valve closed, tighten lock nut (9.4).
3. Place the actuator on the valve bonnet, thread it tight using the ring nut (8.1).
4. Push plug stem (9.5) upward, connect coupling nut (9.3) and actuator stem by means of the stem connector clamps (8.2).

5. Move valve to its end position, align travel indicator scale (9.2) with the tip of the stem connector.

3. Connect coupling nut (9.3) and actuator stem (5.6) using the stem connector clamps (8.2), screw together tightly.
4. Move control valve to its end position, align travel indicator scale (9.2) with tip of the stem connector (8.2), screw tight.

Valve sizes DN 100 to 150 (Series 240, 250 and 280, Kvs 40 to 160)

1. Check that dimension $x = 90$ mm, readjust, if necessary, by turning the coupling nut (9.3).
2. Place linear actuator on the valve bonnet, secure tightly by using the ring nut (8.1).

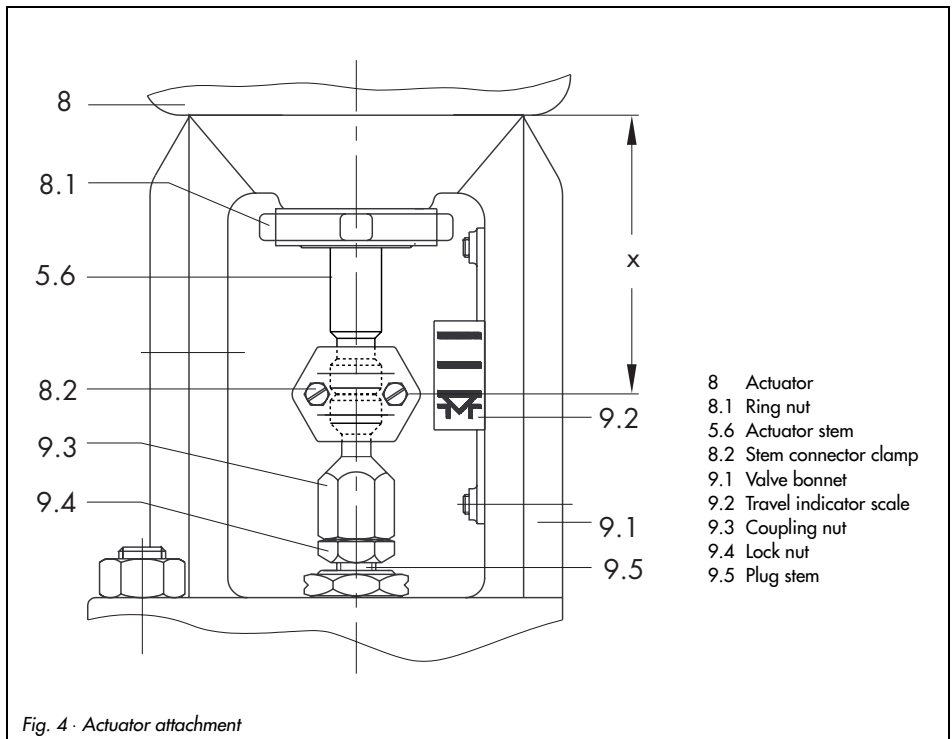

3. Electrical connections



Upon installation of the electric wiring, you are required to observe the regulations governing electrical power plant installation according to DIN VDE 0100 as well as the regulations of your power supplier.

WARNING! Only connect to mains when the power is switched off.

Use power interruption devices which ensure that the power cannot be switched on again unintentionally.

Particularly for 24 V, 50 Hz actuators, use wires with a sufficiently large cross section in order to guarantee that the permissible voltage tolerances of $\pm 10\%$ are not exceeded.

Note:

When electrical connections are made as described in the circuit diagrams, special electronics in the motor ensure that the contacts of controller's output relays (e.g. with three-step controllers) are protected and only a relatively low power load is used. A triac and a relay in the motor electronics connect the power.

- ▶ Remove the side case cover. Guide the wires through the cable glands on the case to the terminals and connect them (see Figs. 5 to 7 or the circuit diagram inside the case cover).

Knock out the sealing plugs next to the existing cable entries, if required, to use two additional cable entries.

- ▶ Connect safety conductor to the separate safety conductor terminal on the inside case wall.

Electrical additional equipment

Connection diagrams 5 to 7 also apply to the additional equipment.

Note that the limit switches must not be connected to the terminal strip but to separate screw terminals.

In the version with positioner (Fig. 6) and position transmitter (Fig. 7), output signals which are proportional to the valve travel can be provided at the terminals 31, 32, 33 to be used for control and signaling purposes (signal increases when the actuator stem retracts).

Important: If any device is connected at the voltage output, terminals 31 and 32 must be jumpered.

Fuses

The board with the electronics section of the motor contains a clamp with a 5 x 20 mm glass-tube fuse which is used to protect the actuator and the contacts of the external controller when the actuator is wired as shown in Figs. 5 to 7.

Supply voltage

230 V, 50/60 Hz T1L 250 (1 A slow fuse),
Actuators with a transit time of 60 s/30 mm travel:

230 V, 50 Hz T1.25, 250 (1.25 slow fuse)

110 V, 50 Hz T1.25 (1.25 A slow fuse)

24 V, 50 Hz T6.3 (6.3 A slow fuse)

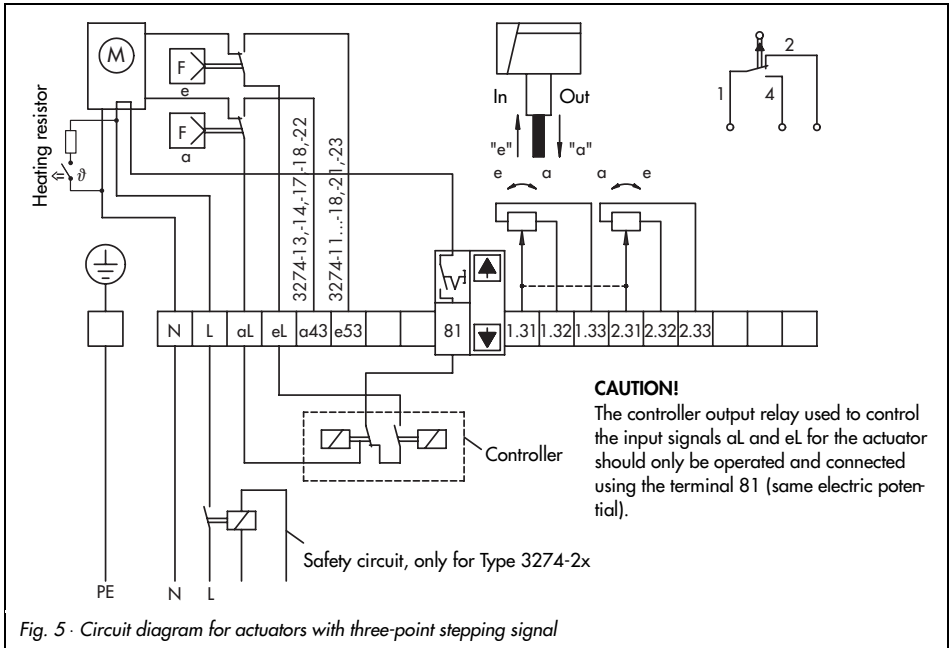

Fig. 5 - Circuit diagram for actuators with three-point stepping signal

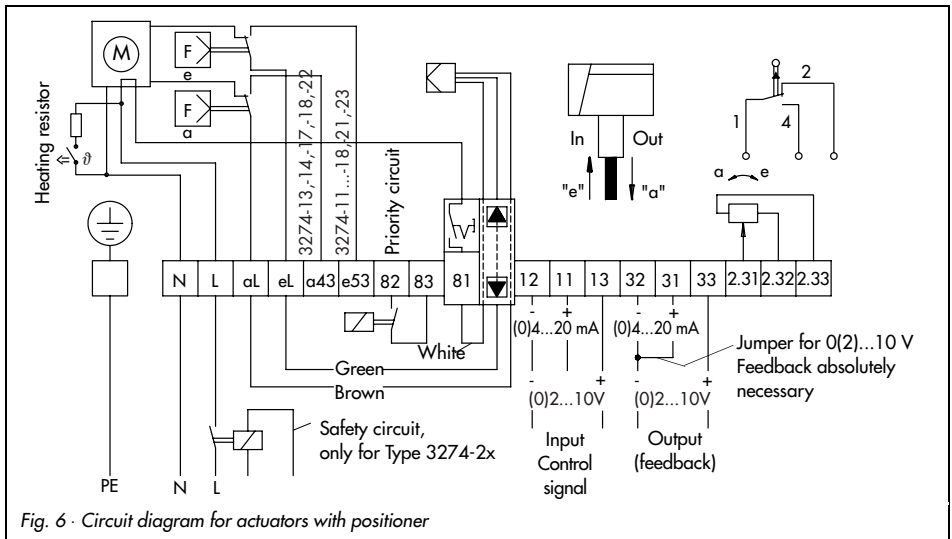

Fig. 6 - Circuit diagram for actuators with positioner

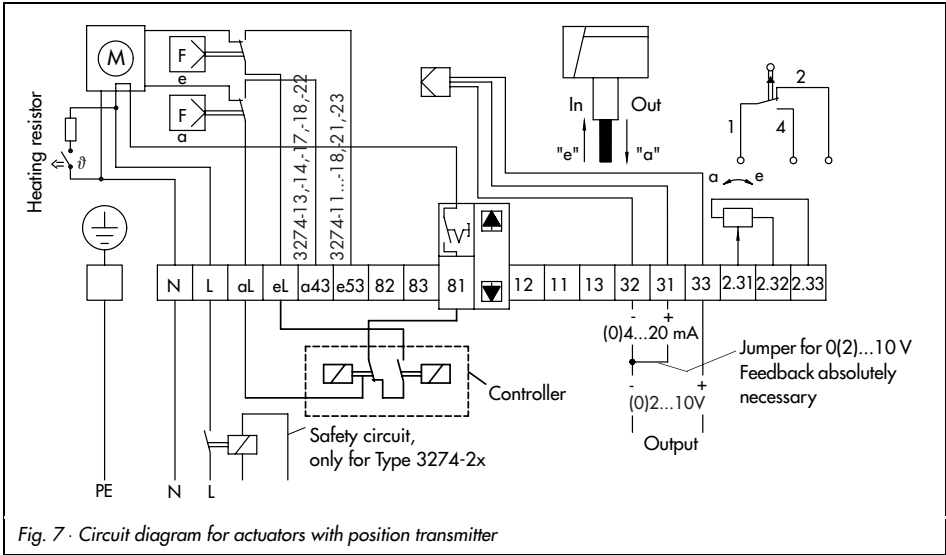

Fig. 7 · Circuit diagram for actuators with position transmitter

4. Operation

4.1 Manual operation of the actuator

4.1.1 Version with electric override

Type 3274-11 to -14 and -22, -23

The actuator stem can be either **retracted** or **extended** by pressing one of the two push-buttons located on the side cover. In this way, the attached valve can be brought into the required position.

After releasing the button, the actuator uses the controller signal again.

Important: If, e.g. upon start-up of the plant, the control signal is to be interrupted and the control valve is to remain in a certain position, the **isolating terminal 81** must be disconnected (Fig. 8).

For this purpose, proceed as follows:

1. **Switch off power**
2. Loosen the two fastening screws on the side case cover and remove cover.
3. Place screwdriver under the release button of the isolating terminal 81 and lever up button until it engages. The red marking pin is not visible.
4. Reinstall cover with screws.
5. Switch on power.

The control signal is now interrupted and the valve can be moved to the desired position by using the two pushbuttons IN and OUT. The valve will then remain in the adjusted position.

If the controller signal must have priority again, proceed as follows:

1. Switch off power. Remove case cover.
2. Firmly press release button until it engages so that the red marking pin becomes visible.
3. Reattach case cover using screws, switch on power.

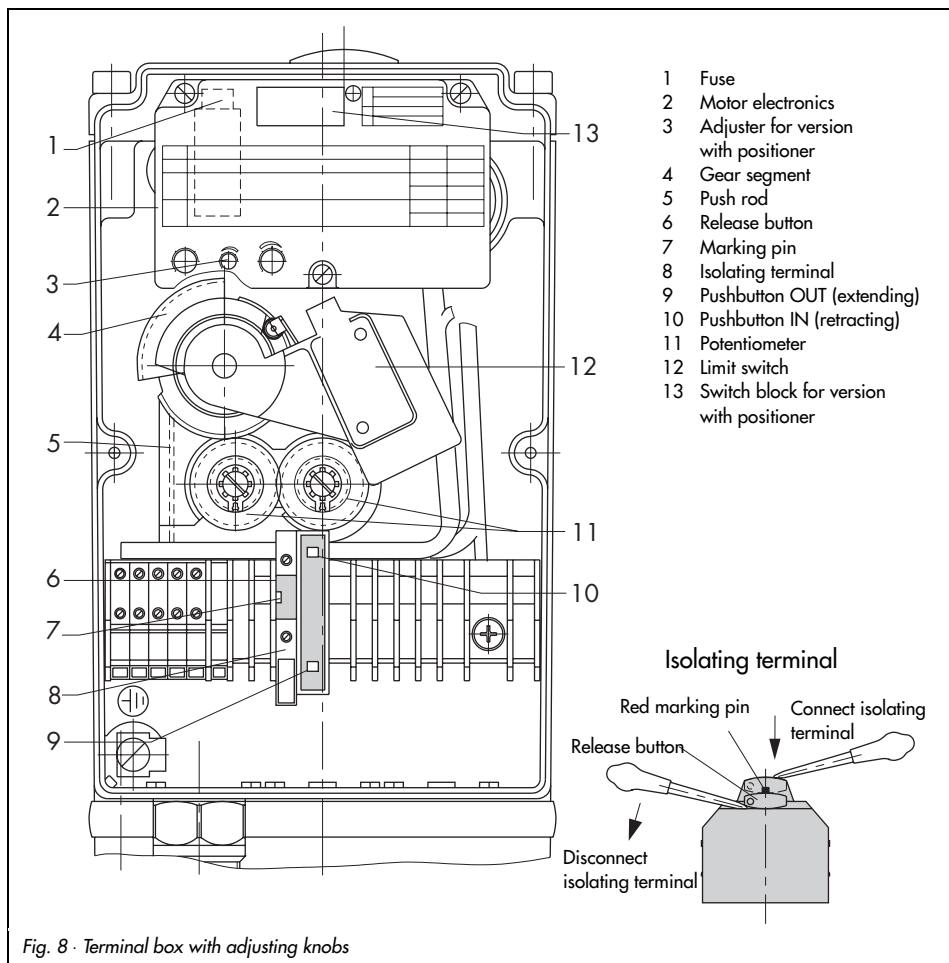

Fig. 8 - Terminal box with adjusting knobs

4.1.2 Version with mechanical override

1. Press black release button located on the top of the actuator case.
2. Use a hexagonal wrench (SW 24) to operate the rack-and-pinion gear at the end of the shaft, projecting out of the case, until you have moved the valve to the desired position.

As soon as the button is released, the actuator operates according to the controller signal again.

If the valve is to remain in the manually adjusted position, the isolating terminal 81 must be disconnected as described in section 4.1.1.

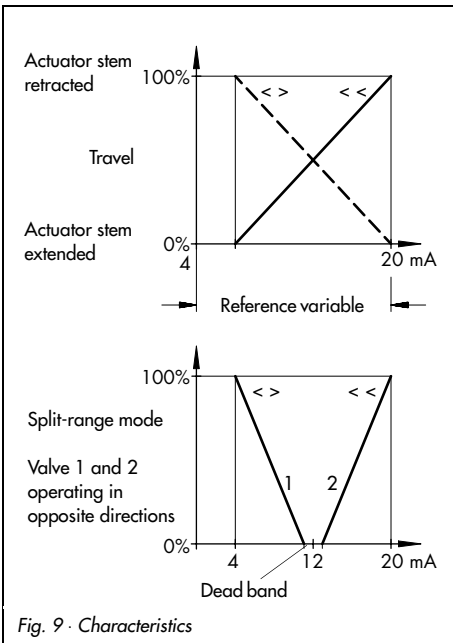

Fig. 9 · Characteristics

4.2 Adjusting additional electric equipment

The actuators can be equipped with different combinations of additional electric equipment. Such equipment can also be retrofitted.

The maximum equipment configuration is shown in the vertical columns of the table below.

Table of additional electric equipment										
Positioner	•	•								
Position transmitter			•	•						
Potentiometer 1	• ¹⁾	• ¹⁾	• ¹⁾	• ¹⁾	•	•	•	•		
Potentiometer 2	•	•	•	•	•	•				
Electric limit switch 1									•	•
Electric limit switch 2	•	•	•	•	•	•			•	
Electric limit switch 3	•	•	•	•	•	•			•	
Inductive limit switch 1	•	•	•	•	•	•			•	•
Inductive limit switch 2	•	•	•	•	•	•			•	•

¹⁾ 1000 Ω, required to transmit position for positioner/ position transmitter

4.2.1 Positioners

The actuator is controlled by a load-independent DC current or DC voltage signal which is used as reference variable w. The valve travel must also be assigned to this reference variable, normally a signal in the range from 4 to 20 (0 to 20) mA or 2 to 10 (0 to 10) V, see Fig. 9.

In the split-range mode, the control valves use smaller reference variables. The controller output signal used to control two valves is divided in such a way that these valves move through their entire travel range each

at half of the input signal range (for example, first control valve adjusted to 12 to 4 mA and second control valve to 12 to 20 mA).

Note for split-range mode:

To prevent the valves from overlapping when they are being adjusted, a dead band as shown in Fig. 9, for example, ± 0.5 mA should be taken into account. Valve 1 would then be set from 11.5 to 4 mA and Valve 2 from 12.5 to 20 mA, the corresponding values also apply for V input signals.

Adjusting knobs

The adjusting knobs (Fig. 10) are located on the cover plate of the electronics unit. To access them, unthread the two screws on the side case cover and remove the cover.



CAUTION! Device is energized!

The following functions can be selected at the switch block **SW** by using the individual switches **SW 1** to **4**.

Priority circuit – SW 1

If an external contact connected to terminals 82 and 83 is closed, the following function results:

SW 1 set to ON – actuator stem retracts.

SW 1 set to OFF – actuator stem extends.

If the contact at terminals 82 and 83 is open, the valve position is determined by the controller signal again.

The mechanical fail-safe action is not affected by the priority circuit used in the actuators.

Operating direction – SW 2

SW 2 set to ON \leftrightarrow actuator stem extends when the reference variable increases.

SW 2 set to OFF \gg actuator stem retracts when the reference variable increases.

Output signal – SW 3 and 4

Depending on the signal connected to terminals 31, 32 and 33

SW 3 and **4** set to ON — 4 to 20 mA or 2 to 10 V

SW 3 and **4** set to OFF — 0 to 20 mA or 0 to 10 V

Important: Both switches **SW 3** and **SW 4** must be in the same position!

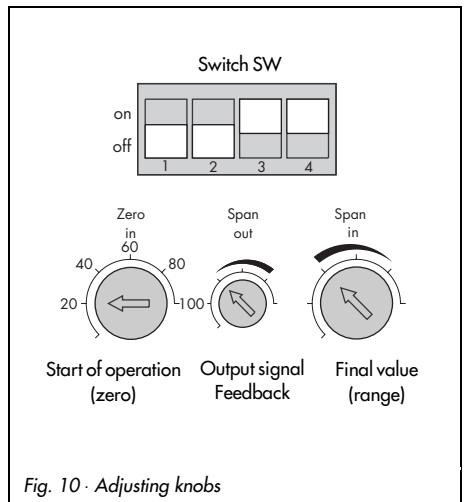

Fig. 10 · Adjusting knobs

Adjustments at the valve

The following description refers to a globe valve which closes when the actuator stem extends and to a three-way valve which provides tight closure of two ports.

The reference variable selected is 4 to 20 mA.

Pre-adjustments:

(required for both operating directions >> and <<)

1. Open **isolating terminal 81** by pulling up the release button (Fig. 8).
2. Use the manual override to move the control valve to the lower end position, i.e. the actuator stem must be extended as far as it will go in the valve seat. With an electric override, press the + button, with a mechanical override, operate the rack-and-pinion gear (sections 3.1.1 and 3.1.2).
3. Turn the associated gear segment around its axis according to the nominal travel of the control valve (15 or 30 mm) until the marking arrow is above the point where the gears mesh (Fig. 11).
4. Hold the gear segment and the gear in this position. Then use a screwdriver to turn the axis of the feedback potentiometer P1 to the right as far as it will go.
5. Select output signal for valve position indication at the switches SW 3 and SW 4.
6. Connect a suitable current or voltage source (or controller) to the input signal terminals (reference variable w). Subsequently connect an ammeter for

valve position indication to the terminals 31, 32.

Operating direction >> :

7. Set switch SW 2 to **OFF**.
Turn Zero adjusting knob to the left as far as it will go (0 %) and **Span_{in}** adjusting knob to the mid position (mark).
8. Set input signal to the starting point (4 mA) on the current source.
9. Slowly turn **Zero** adjusting knob clockwise until the LED turns off and then continue to turn it slightly until the LED lights up again. This causes the maximum closing force to be produced in the valve.
10. Use manual override to move the valve to the upper end position, i.e. retract the actuator stem.

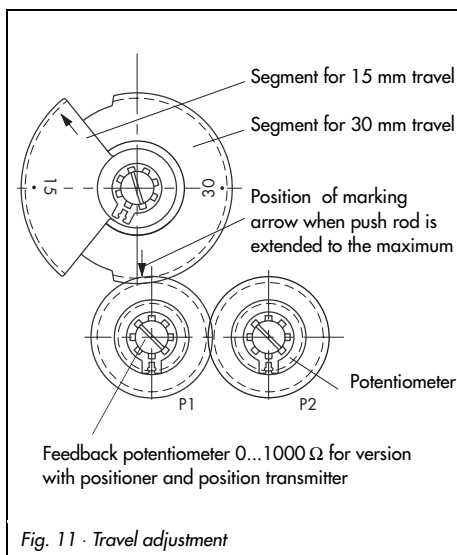

Fig. 11 · Travel adjustment

11. Set input signal at the current source to the end value (20 mA).
12. Turn **Span_{out}** adjusting knob until the ammeter indicates an output signal of 20 mA.
13. Turn **Span_{in}** adjusting knob all the way to the left. Then slowly turn back to the right to the point where the LED just turns off (when a globe valve is open). Continue turning in the same direction a little bit more until the LED lights up again (when the second port of a three-way valve is closed) in order to produce maximum closing forces.
14. If you do not want to change the operating direction to \leftrightarrow , **close isolating terminal 81** by pressing the release button.

Operating direction \leftrightarrow

15. Set switch SW 2 to ON.
Turn **Zero** adjusting knob to the right as far as it will go (100 %).
16. Set input signal to starting point 4 mA again.
17. Slowly turn Zero adjusting knob towards the left to the point where the LED turns off (when a globe valve is open). Then turn slightly in the same direction until the LED just lights up again (when the second port of a three-way valve is closed) in order to produce maximum closing forces.

Do not operate any other adjusting knob after that!

18. **Close isolating terminal 81** by pressing the release button.

Note:

The positioner can also be used as a "mere position transmitter".

To proceed, remove the wires that lead from the positioner case to the terminals aL and eL and strip the insulation off the free wire ends.

Then wire the wires of the external three-point stepping signal (controller) to the terminals aL, eL and 81.

The terminals 11, 12 and 13 as well as the priority circuit no longer function.

4.2.2 Position transmitter

1. Select the output signal for position transmitter at switch SW 3 and SW 4.
SW 3 and **4** to ON = 4 to 20 mA or 2 to 10 V
SW 3 and **4** to OFF = 0 to 20 mA or 0 to 10 V.
2. Connect an ammeter to terminals 31, 32 or after jumpering the terminals 32 and 31 connect a voltmeter to terminals 32 and 33 to indicate the valve position.
3. Move the valve to the lower end position, i.e. the actuator stem must be extended as far it will go into the valve seat using the manual override (section 4.1) or controller signal.
4. Turn the associated gear segment around its axis according to the nominal travel of the control valve (15 or 30 mm) until the marking arrow is above the point where the gears mesh (Fig. 11).
5. Hold the gear segment and the gear in this position. Then use a screwdriver to turn the axis of the feedback poten-

tiometer **P1** to the right as far as it will go.

6. Turn potentiometer **P1** in the opposite direction until the required initial value of the output signal is indicated on the measuring instrument.
7. Open the control valve, the final value of the output signal should be indicated on the measuring instrument. If the value is incorrect, readjust the final value correspondingly at the **Span_{out}** adjusting knob.
The feedback signal increases as the actuator stem retracts.
If a signal with decreasing characteristic is required, reverse the white and green connecting wires at the potentiometer.

4.2.3 Potentiometers

The actuator can be equipped with either one or two potentiometers (Fig. 11), depending on its version. Actuators equipped with a positioner require a potentiometer (P1) for internal valve position feedback. Its resistance value cannot be used for external signaling purposes.

Potentiometer **P1**:

1. Extend actuator stem all the way into the valve.
2. Depending on the nominal travel of the valve, turn gear segment 15 or 30 mm on its axis until the marking arrow is above the point where the gears mesh (Fig. 11).
3. Hold gear segment and gear in this position. Then use a screwdriver to turn the axis of the potentiometer P1 all the way to the **right**.

Potentiometer **P2**:

This potentiometer is driven by the pinion of potentiometer P1. Opposed resistance values arise.

Adjust potentiometer as described for P1, however, turn axis to the **left** as far as it will go while holding the gear segment and the gear.

4.2.4 Limit switches

The switching point of the additional limit switches (Fig. 12) is infinitely adjustable within the travel range.

Electric limit switches:

- ▶ Move control valve to the desired switching position, turn adjustment screw until the operating cam contacts the roller and reverses the microswitch. If necessary, move actuator in opposite direction, check whether the cam reaches the switching point at the desired switching position.

Inductive limit switches:

When using inductive contacts, isolating switch amplifiers must be connected in the output circuit according to EN 50 227.

- ▶ Move control valve to the desired switching position. Turn adjustment screw until the metal tag triggers the contact.

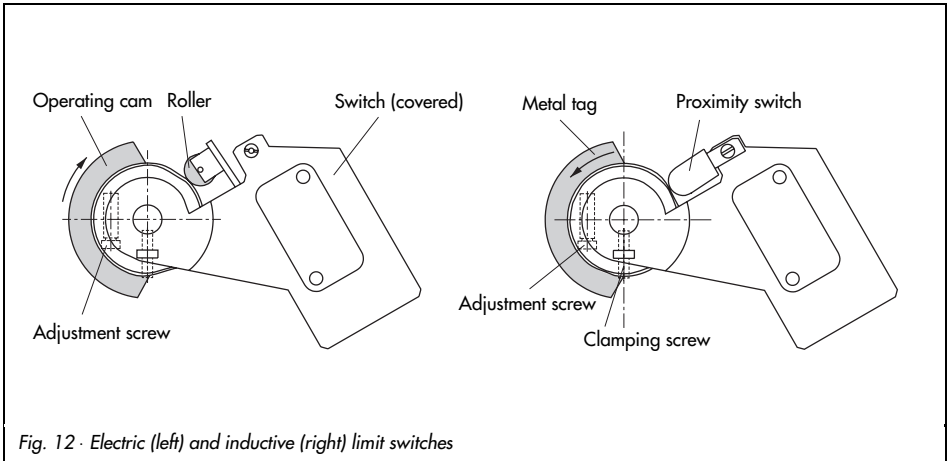

5. Dimensions in mm

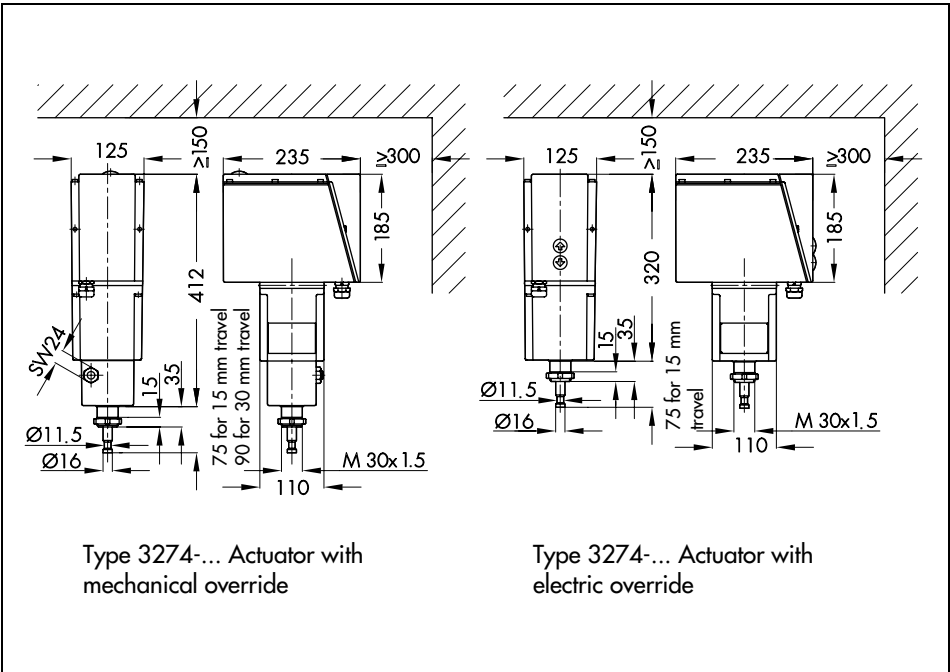



SAMSON AG · MESS- UND REGELTECHNIK
Weismüllerstraße 3 · 60314 Frankfurt am Main · Germany
Phone: +49 69 4009-0 · Fax: +49 69 4009-1507
Internet: <http://www.samson.de>

EB 8340 EN

S/Z 2008-07