

# Type 4765 Pneumatic Positioner

SAMSON



Type 4765 Pneumatic Positioner

## Mounting and Operating Instructions

**EB 8359-1 EN**

Edition April 2014

CE

## Definition of signal words



### **DANGER!**

*Hazardous situations which, if not avoided, will result in death or serious injury*



### **WARNING!**

*Hazardous situations which, if not avoided, could result in death or serious injury*



### **NOTICE**

*Property damage message or malfunction*



### **Note:**

*Additional information*



### **Tip:**

*Recommended action*

<b>1</b>	<b>General safety instructions</b> .....	<b>5</b>
<b>2</b>	<b>Article code</b> .....	<b>6</b>
<b>3</b>	<b>Technical data</b> .....	<b>7</b>
<b>4</b>	<b>Design and principle of operation</b> .....	<b>8</b>
<b>5</b>	<b>Attachment</b> .....	<b>10</b>
5.1	Attachment to valve with cast yoke .....	10
5.2	Attachment to valve with rod-type yoke.....	10
5.3	Housing cover .....	10
<b>6</b>	<b>Pneumatic connections</b> .....	<b>12</b>
6.1	Pressure gauge .....	12
6.2	Supply pressure .....	12
<b>7</b>	<b>Operation</b> .....	<b>13</b>
7.1	Assignment of the positioner and the actuator .....	13
7.1.1	Determining and changing the operating direction .....	14
7.2	Starting point and reference variable.....	16
7.3	Adjustment after mounting the positioner on the valve.....	16
7.3.1	Setting the air delivery (volume restriction Q) and proportional band Xp.....	16
7.3.2	Setting for actuator with fail-safe action "stem extends" .....	18
7.3.3	Setting for actuator with fail-safe action "stem retracts" .....	18
7.4	Exchanging the range spring .....	19
<b>8</b>	<b>Upgrading the pneumatic positioner</b> .....	<b>20</b>
<b>9</b>	<b>Accessories, mounting parts and conversion kits</b> .....	<b>22</b>
<b>10</b>	<b>Dimensions in mm</b> .....	<b>23</b>



# 1 General safety instructions

For your own safety, follow these instructions concerning the mounting, start-up and operation of the positioner:

- The positioner is to be mounted, started up or operated only by trained and experienced personnel familiar with the product. According to these mounting and operating instructions, trained personnel refers to individuals who are able to judge the work they are assigned to and recognize possible dangers due to their specialized training, their knowledge and experience as well as their knowledge of the applicable standards.
- Any hazards that could be caused in the valve by the process medium and the operating pressure or by moving parts are to be prevented by taking appropriate precautions.
- If inadmissible motions or forces are produced in the pneumatic actuator as a result of the supply pressure level, it must be restricted using a suitable supply pressure reducing station.

To avoid damage to any equipment, the following also applies:

- Proper shipping and storage are assumed.



**Note:**

*Devices with a CE marking fulfill the requirements of the Directives 2014/34/EU and 2014/30/EU.*

*The Declaration of Conformity is available on request.*

---

## 2 Article code

Pneumatic positioner	Type 4765-	0	1	x	0	0	x	1	x	x	x	x	0
Spring													
Spring 1, travel = 15 mm			1										
Spring 2, travel = 30 mm, split range 15 mm			2										
Spring 3, travel = 60 mm, split range 30 mm			3										
Pneumatic connections													
ISO 228/1 G 1/4							1						
1/4-18 NPT							3						
Temperature range													
Standard								0					
Low temperature down to -50 °C								1					
Special version													
Without									0	0	0		
For oxygen <sup>1)</sup>									0	1	6		

<sup>1)</sup> Special version suitable for oxygen up to maximum +60 °C (according to AIR LIQUIDE test report no. 2014/R 171a1)

### 3 Technical data

Controlled variable (travel range)	7.5 to 60 mm, with lever extension: 7.5 to 90 mm
Reference variable	0.2 to 1 bar (3 to 15 psi)
Split-range 0 to 50 % or 50 to 100 % reference variable span (up to 50 mm travel)	0.2 to 0.6 bar (3 to 9 psi) and 0.6 to 1 bar (9 to 15 psi)
Range spring	See Table 1 on page 17 for selection
Supply air	Supply air: 1.4 to 6 bar (20 to 90 psi) Air quality acc. to ISO 8573-1: Max. particle size and density: Class 4 Oil content: Class 3 · Pressure dew point: Class 3
Signal pressure $p_{st}$ (output)	Max. 0 to 6.0 bar (0 to 90 psi)
Characteristic	Linear characteristic · Deviation from characteristic according to terminal point method: $\leq 1.5\%$
Hysteresis	$< 0.5\%$
Sensitivity	$< 0.1\%$
Operating direction	Reversible
Proportional band $X_p$ (at 1.4 bar supply air)	1 to 3.0 % with spring 1 1 to 2.0 % with spring 2 1 to 1.5 % with spring 3
Air consumption in steady state, $X_p = 1\%$	With 1.4 bar supply air: $0.13 \text{ m}_n^3/\text{h}$ With 6 bar supply air: $0.33 \text{ m}_n^3/\text{h}$
Air output	At $\Delta p = 1.4 \text{ bar}$ : $3.0 \text{ m}_n^3/\text{h}$ · At $\Delta p = 6 \text{ bar}$ : $8.5 \text{ m}_n^3/\text{h}$
Transit time with Type 3271 Actuator, "stem extends"	$240 \text{ cm}^2 \leq 1.8 \text{ s}$ · $350 \text{ cm}^2 \leq 2.5 \text{ s}$ · $700 \text{ cm}^2 \leq 10 \text{ s}$
Permissible ambient temperature <sup>1)</sup>	$-20$ to $80 \text{ }^\circ\text{C}$ (special version for oxygen: up to max. $+60 \text{ }^\circ\text{C}$ )
Influences	Temperature: $< 0.02\% / 1 \text{ K}$ Supply air: $< 0.20\% / 0.1 \text{ bar}$ Variable position when turned by $180^\circ$ : $< 3.50\%$
Degree of protection	IP 54 · Venting over check valve (1790-7408); IP 65
Compliance	<b>EAC</b>
Weight	Approx. 1.1 kg
Materials	Housing: Die-cast aluminum, chromated and plastic coated External parts: Stainless steel

<sup>1)</sup> Extended temperature range on request

## 4 Design and principle of operation

The pneumatic positioner is used to assign the valve position (controlled variable) to the input signal (reference variable). The positioner compares the control signal issued by a control system to the travel of the control valve and issues a signal pressure (output variable) for the pneumatic actuator.

The positioner consists of the lever with shaft and range spring, the measuring diaphragm and the pneumatic control system with nozzle, flapper plate and booster. In addition, a pressure gauge can optionally be attached for the control signal (input) and the signal pressure (output signal).

The positioner operates according to the force-balance principle. In this way, the motion of the actuator stem or the plug stem (controlled variable  $x$ ) is transmitted to the lever (1) and the range spring (6) over the plate (20). This action twists the range spring and varies its spring force.

The reference variable, i.e. the control signal ( $p_e$ ) of the upstream controller, produces a force which acts on the surface of the measuring diaphragm (8) and is compared to the force of the range spring (6). At the same time, the motion of the measuring diaphragm is transferred to the flapper plate (10.2) over the feeler pin (9.1), and the nozzle (10.1) releases pressure. The supply air is fed to the booster (12) and flows through the  $X_p$  restriction (13) and the nozzle (10.1) and hits the flapper plate (10.2).

Any change in the control signal  $p_e$  or the valve position causes the pressure to change upstream or downstream of the booster. The air controlled by the booster (signal pressure  $p_{st}$ ) flows through the volume restriction (14) to the pneumatic actuator, causing the plug stem to move to a position corresponding to the reference variable.

The adjustable restrictions (13 and 14) are used to optimize the positioner control loop.

The range spring (6), which can be exchanged, is assigned to both the rated valve travel and the span of the reference variable.

### Legend for Fig. 1 and Fig. 2

1	Lever for valve travel
1.1	Shaft
2	Pin
2.1	Nut
3	Sleeve
4	Zero point adjustment
5	Fastening screw
6	Range spring
6.1	Bracket
7	Fastening screw
8	Measuring diaphragm
9	Diaphragm lever
9.1	Feeler pin
10	Nozzle block
10.1	Nozzle
10.2	Flapper plate
11	Cover plate
12	Booster
13	$X_p$ restriction
14	Volume restriction $Q$
15	Hole for fastening screw
20	Plate



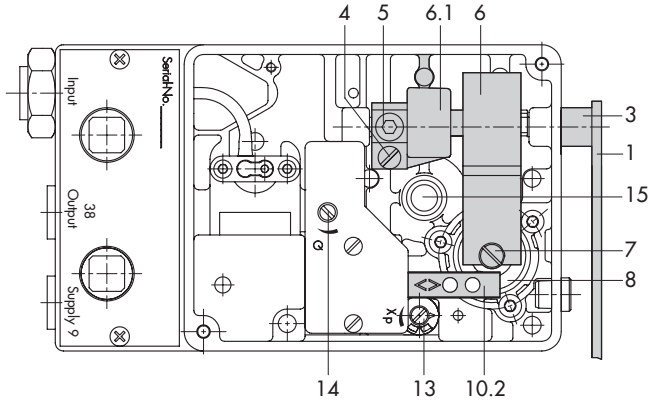

Fig. 1: Positioner (opened)

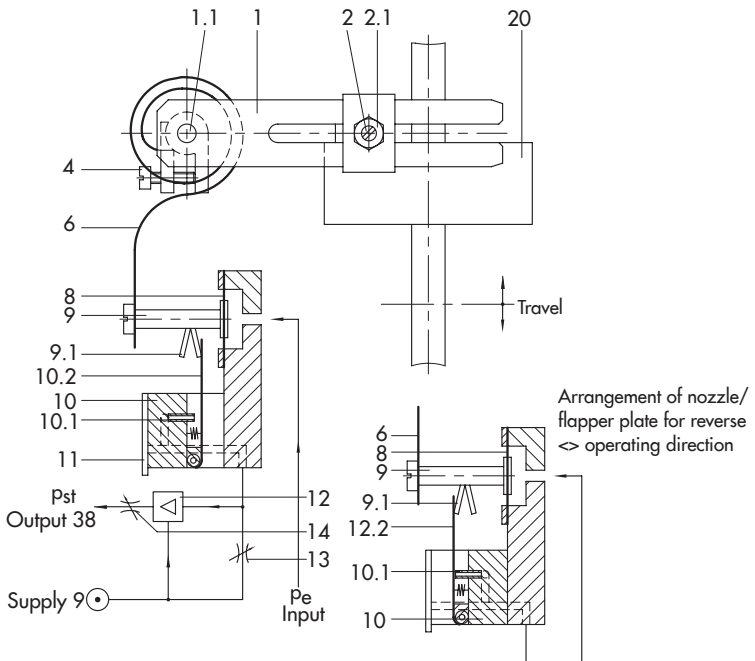

Fig. 2: Functional diagram

## 5 Attachment

To attach the positioner to valves with cast yokes), mounting parts (order no. 1400-5745) are used. For valves with rod-type yokes (pillars), the mounting kit (order no. 1400-5745) and additionally the mounting kit (order no. 1400-5342) are necessary (see page 22).

Since the positioner can be attached on either side of the valve, the physical location (left or right attachment) should be determined before actual attachment.

➔ See Fig. 5 to Fig. 8 on page 13.

### 5.1 Attachment to valve with cast yoke

1. Fasten the plate (20) to the stem connector (22) of the valve using the screws (21).
2. Unscrew the positioner cover, and secure the positioner to the valve yoke using the fastening screw (15). Make sure that the pin (2) is inserted through the wire strap and, as a result, clamped against the plate (20).

### 5.2 Attachment to valve with rod-type yoke

1. Fasten the plate (20), off-centered, to the travel indicator (24) of the plug stem (23) using the screws (21).
2. Place both the support (28) and the clamping plate (26) on the rod (27) and lightly fasten. Move the support until both the center of the plate (20) and the support (28) are aligned when the valve is at half of the valve travel.
3. Fasten tight the support and the clamping plate.
4. Mount the positioner to the support using the fastening screw (15). Make sure that the pin (2) is inserted through the wire strap and, as a result, clamped against the plate (20).

### 5.3 Housing cover

After attaching the positioner, make sure that the vent plug of the housing cover faces downward when the valve is installed.

#### Legend for Fig. 3 and Fig. 4

1	Lever
2	Pin
2.1	Nut
15	Fastening screw
20	Plate
21	Screw
22	Stem connector
23	Plug stem
24	Travel indicator
26	Clamping plate
27	Rod (pillar)
28	Support

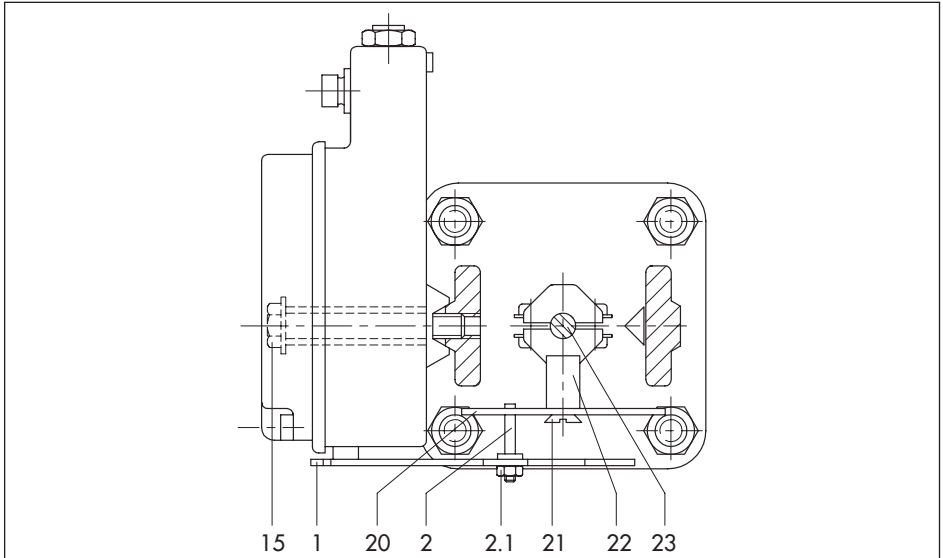

**Fig. 3:** Attachment to valves with cast yokes (NAMUR rib)

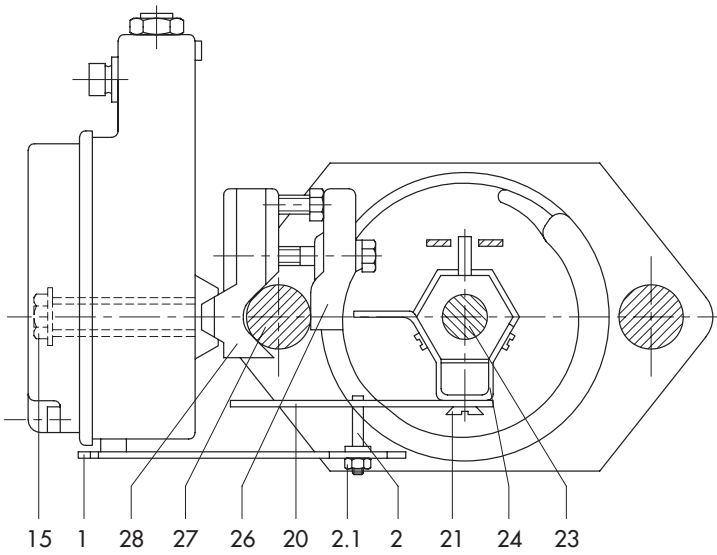

**Fig. 4:** Attachment to valves with rod-type yokes

## 6 Pneumatic connections

The pneumatic connections are optionally designed as a bore with NPT or ISO 288/1-G thread.

Customary fittings for metal or copper tubing or plastic hoses can be used.



### NOTICE

*Risk of malfunction due to failure to comply with required air quality.*

- Only use supply air that is dry and free of oil and dust.
- Read the maintenance instructions for upstream pressure reducing stations.
- Blow through all air pipes and hoses thoroughly before connecting them.

### 6.1 Pressure gauge

To monitor the positioner, we recommend installing pressure gauges for the supply air and signal pressure. The required parts are listed on page 22.

### 6.2 Supply pressure

The required supply air pressure depends on the bench range and the actuator's operating direction (fail-safe action).

The bench range is written on the nameplate either as the spring range or signal pressure range. The operating direction is marked **FA** or **FE**, or by a symbol.

#### Actuator stem extends (FA)

##### Fail-close

(for globe and angle valves)

Required supply pressure =  
Upper bench range value + 0.2 bar,  
minimum 1.4 bar

#### Actuator stem retracts (FE)

##### Fail-open

(for globe and angle valves)

For tight-closing valves, the maximum signal pressure  $p_{st,max}$  is roughly estimated as follows:

$$p_{st,max} = F + \frac{d^2 \cdot \pi \cdot \Delta p}{4 \cdot A} \text{ [bar]}$$

d = Seat diameter [cm]

$\Delta p$  = Differential pressure across the valve [bar]

A = Actuator diaphragm area [cm<sup>2</sup>]

F = Upper bench range value of actuator [bar]

**If there are no specifications, calculate as follows:**

Required supply pressure =  
Upper bench range value + 1 bar

The positioner output pressure is routed to the top or bottom diaphragm case of the actuator as shown in Fig. 5 to Fig. 8.

## 7 Operation

### 7.1 Assignment of the positioner and the actuator

Arrangement of the actuator, the mounting position of the positioner, the reference variable and the operating direction:

→ See Fig. 5 to Fig. 8

When any subsequent changes are made, e.g. reversing the operating direction of the positioner control loop or changing the actuator fail-safe action from “actuator stem ex-

tends” to “actuator stem retracts” or vice versa, the positioner's mounting position must be changed accordingly.

#### Actuator stem extends (FA)

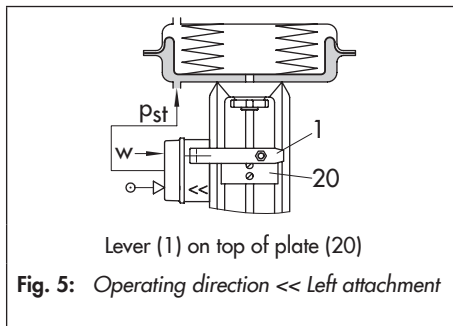

Fig. 5: Operating direction << Left attachment

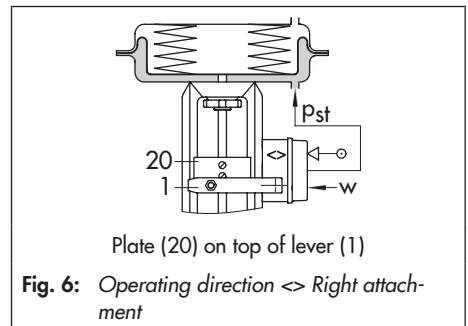

Fig. 6: Operating direction <=> Right attachment

#### Actuator stem retracts (FE)

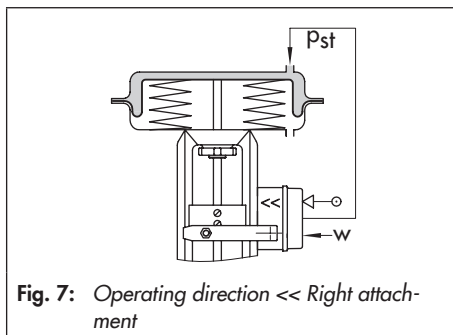

Fig. 7: Operating direction << Right attachment

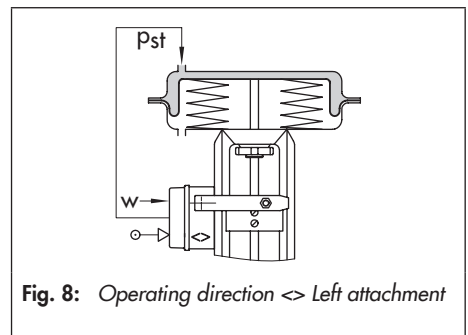

Fig. 8: Operating direction <=> Left attachment

### 7.1.1 Determining and changing the operating direction

For an increasing input signal (reference variable), the signal pressure  $p_{st}$  can either be increasing (direct action <<) or decreasing (reverse action <>).

Similarly, as the reference variable decreases, the signal pressure can either decrease (direct action <<) or increase (reverse action <>).

On the flapper plate, the operating direction is indicated by symbols (direct <<, reverse <>). Depending on the position of the flapper plate, the adjusted operating direction and the associated symbol become visible.

If the required operating direction does not correspond to the visible symbol, or if the operating direction is to be changed, proceed as follows:

1. Unscrew both screws on the cover plate, and lift off the nozzle block along with the cover plate.
2. Reinstall the nozzle block turned 180° together with the cover plate, and refasten.

Make sure that the nozzle block and flapper plate are correctly located above or below the feeler pin as shown in Fig. 9.

If the operating direction is to be changed after the initially determined arrangement of positioner and actuator, note that the positioner must be mounted in a different location and the nozzle block must be turned.

Make sure the location of the lever (1) and the plate (20), "lever on top of plate" or re-

versed "plate on top of lever" is correct (Fig. 5 to Fig. 8).

Operating direction increasing/increasing (direct <<)  
feeler pin on top of flapper plate

Operating direction increasing/decreasing (reverse <>)  
flapper plate on top of feeler pin

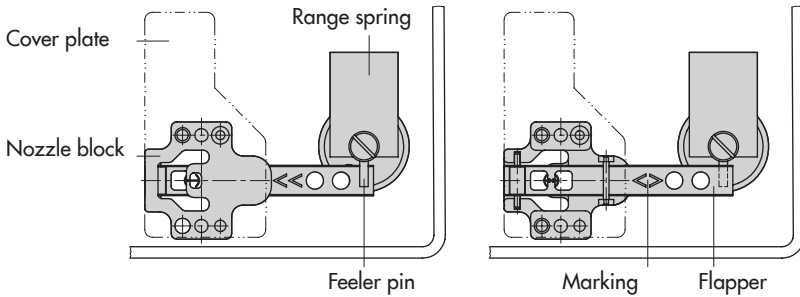

Fig. 9: Position of nozzle block, cover plate removed

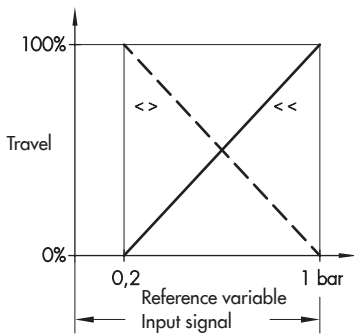

Fig. 10: Normal operation

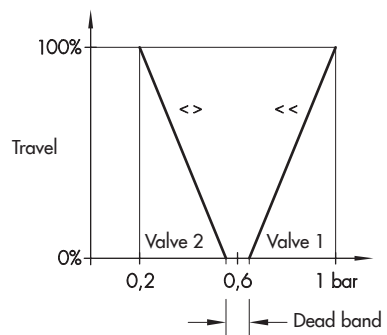

Fig. 11: Split-range operation, two valves operating in opposing directions

## 7.2 Starting point and reference variable

The attached lever and the installed range spring of the positioner are assigned to the values of rated valve travel and the reference variable (input signal) as in Table 1.

In normal operation, the reference variable span is  $100\% = 0.8$  bar. A smaller span of, for example,  $50\% = 0.4$  bar is only required for split-range operation (Fig. 11).

The span can be changed by exchanging the range spring (section 7.4).

On making adjustments to the positioner, the travel must be adapted to the reference variable and vice versa.

With a reference variable, for example, 0.2 to 1 bar, the valve must move through its entire travel range from 0 to 100 %.

The starting point then is 0.2 bar and the upper range value 1 bar.

In split-range operation, the controller output signal is used to control two control valves, dividing it such that the valves move through their entire travel range at half the input signal range each (e.g. first valve set to 0.2 to 0.6 bar, second valve set to 0.6 to 1 bar). To avoid overlapping, allow for a dead band of 0.05 bar as shown in Fig. 11.

The starting point (zero) is adjusted at the screw (4); the reference variable span, i.e. the upper range value, is adjusted at the pin (2).

## 7.3 Adjustment after mounting the positioner on the valve

Connect the control signal input to a compressed air source of max. 1.5 bar using a remote adjuster and a pressure gauge. Connect the supply air to the supply input (supply 9).

### 7.3.1 Setting the air delivery (volume restriction Q) and proportional band Xp

1. Close the volume restriction (14) as far as the required positioning speed permits.  
Check the positioning speed by pushing the range spring (6) as far it will go.
2. Adjust the reference variable at the input to approx. 50 % of its range. Then, turn the zero adjustment screw (4) until the valve is at approximately 50 % valve travel.

On setting the Xp restriction, observe the relationship with the supply air pressure as indicated in Fig. 12. The preset value of Xp should be approximately 3 %.

3. Check the plug stem's tendency to oscillate by pressing the range spring (6) briefly as far as it will go.  
The Xp value is to be adjusted to be as small as possible, without considerable overshooting occurring.

#### Additional points that apply concerning adjustment:

- Always adjust the Xp restriction before setting the starting point.



- ➔ In case of a zero shift (e.g. due to a subsequent change in the restriction setting or supply pressure), check the zero setting and readjust it.
- ➔ The adjustment range of the Xp restriction is restricted by the pointer and stop to one turn (Fig. 12). Do not remove the pointer!

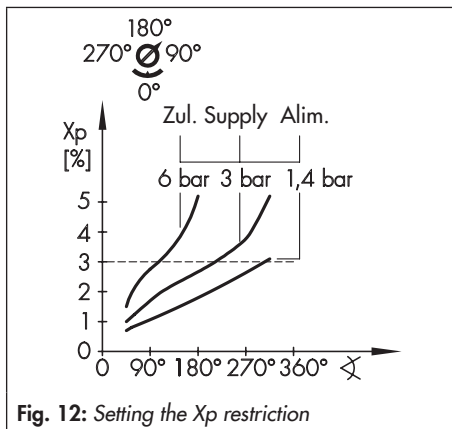

Fig. 12: Setting the Xp restriction

If the pointer has been removed unintentionally, an initial setting can be performed as follows:

1. Close the restriction by turning it clockwise until you feel a slight resistance.
2. Based on this position, open the restriction one quarter turn.
3. Press on the plastic ring with the pointer at the 0° position.
4. Set the restriction in the range between 90° and 180°.
5. Set Xp as described in section 7.3.1.

Table 1: Range springs

Rated travel [mm]	Min./max. travel [mm]	Reference variable (input signal)	Range spring
Standard travels for SAMSON valves with lever l (40 to 127 mm in length)			
15	7.5 to 15	100 % 50 %	1 2
30	14 to 32	100 % 50 %	2 3
60	30 to 70	100 %	3
Further travel ranges with lever l and lever extension (40 to 200 mm in length)			
20	7.5 to 26	100 % 50 %	1 2
40	14 to 50	100 % 50 %	2 3
> 60	30 to 90	100 %	3

### 7.3.2 Setting for actuator with fail-safe action "stem extends"

To ensure that the total closing force of the actuator acts on the valve, proceed as follows:

- ➔ With direct operating direction <<: adjust starting point to 0.23 bar (slightly raised).
- ➔ With reverse operating direction <>: adjust starting point to 0.97 bar (slightly lowered).

#### Starting point (zero) e.g. 0.23 bar

1. Turn the zero adjustment screw (4) until the plug stem just starts to move out of its resting position (observe travel indicator).
2. Reduce the input signal to 0 bar and slowly increase it again. Check whether the plug stem starts to move at exactly 0.23 bar and correct, if necessary.

#### Upper range value (span) e.g. 1 bar

3. Once the starting point has been set, increase the input signal. At exactly 1 bar, the plug stem must stand still, having moved through 100 % travel (watch the travel indicator at the valve).

If the upper range value is incorrect, move the pin (2) as follows to correct it:

4. Move towards
 

Lever end	➔	To increase the travel
Fulcrum	➔	To reduce the travel

After correcting the input signal, re-adjust zero. Then check the upper range value again.

Repeat the correction procedure until both values are correct.

If a pressure gauge is available, check whether the actuator is completely vented at an input signal of exactly 0.2 bar (operating direction <<) or exactly 1.0 bar (operating direction <>).

### 7.3.3 Setting for actuator with fail-safe action "stem retracts"

When using an actuator with "actuator stem retracts" fail-safe action, the diaphragm chamber must be pressurized with a signal pressure that is high enough to tightly close the valve against the upstream pressure in the plant.

- ➔ Operating direction <<: Upper range value of reference variable 1 bar
- ➔ Operating direction <>: Lower range value of reference variable 0.2 bar

The required signal pressure is either indicated on the positioner label or the required supply pressure can be roughly calculated as described in section 6.2.

#### Starting point (zero) e.g. 1 bar

1. Adjust the input signal to 1 bar at the pressure adjuster.  
Turn the zero adjustment screw (4) until the valve just starts to move from its initial position.

2. Increase the input signal and slowly reduce it again to 1 bar. Check whether the valve starts to move at exactly 0.1 bar.  
Correct any deviation at the zero adjustment screw (4).
  - Turn it counterclockwise to move the valve earlier from its final position
  - Turn it clockwise to move the valve later from its final position
2. Exchange range spring. Slide lever with shaft through sleeve (3), positioner housing and bracket (6.1).
3. Secure range spring with the screw (7).
4. Move bracket and shaft until the screw (5) sits on the flattened part of the shaft. Tighten screw (5). Allow for a play of 0.05 to 0.15 mm between the lever (1) and the sleeve (3) as well as between the range spring (6) and the positioner housing.

#### Upper range value (span) e.g. 0.2 bar

3. Once the starting point has been set, increase the input signal to 0.2 bar at the pressure adjuster.  
At exactly 0.2 bar, the plug stem must stand still, having moved through 100 % travel (watch the travel indicator at the valve).
4. If the upper range value is incorrect, move the pin (2) to correct it. Readjust 1 bar and turn the zero adjustment screw (4) until the pressure gauge indicates the required signal pressure (see also 6.2).  
If no pressure gauge has been installed, set the starting point to 0.97 bar instead.

## 7.4 Exchanging the range spring

If the range is to be altered or changed to split-range operation, replace the range spring as shown in Fig. 1 as follows:

1. Unscrew screw (7) on the range spring. Undo hexagon socket screw (5) and pull out the lever together with shaft.

### 8 Upgrading the pneumatic positioner

The pneumatic positioner can be converted into a Type 4763 Electropneumatic Positioner with a conversion kit.



**Note:**

*The version suitable for oxygen of the Type 4765 Pneumatic Positioner cannot be converted to form a Type 4763 Electropneumatic Positioner.*

Besides the required Type 6109 or Type 6112 i/p module (see Fig. 13), the associated conversion kit (including printed circuit boards, cable gland and mounting screws) must be ordered.



**Note:**

*For details on the converted Type 4763 Positioner, refer to Mounting and Operating Instructions ► EB 8359-2 EN.*

#### With Type 6109:

1. Undo the connecting plate (6) and remove along with sealing element (7). Pull off the hose (5).
2. Unscrew the connecting nipple (4) from the housing.
3. Push the i/p module over the plug connection onto the printed circuit board.
4. Insert the sealing element (7), on the bottom, into the opening of the printed circuit board so that the restriction with filter (8) are situated on the right side

above the innermost of the two housing holes (supply air) when the module (dashed line in Fig. 13) is installed.

5. Secure the module and the printed circuit board in the housing (two screws for the module, one screw for the printed circuit board). Subsequently assemble the cable gland (1) along with the seal.

#### With Type 6112:

1. Proceed as described in steps 1 and 2 of Type 6109
2. Place the i/p module on the plug of the printed circuit board, and tighten the side terminal screws.
3. Check whether the seals (10, 11) are properly inserted on the bottom side. When the module (dashed line in Fig. 13) is installed, the seal with restriction and filter must be situated on the right side above the innermost of the two housing holes (supply air).
4. Secure the module and the printed circuit board in the housing (two screws for the module, one screw for the printed circuit board). Subsequently assemble the cable gland (1) along with the seal.

#### Legend for Fig. 13

- |    |                       |
|----|-----------------------|
| 1  | Cable gland           |
| 2  | Printed circuit board |
| 3  | i/p converter module  |
| 4  | Connecting nipple     |
| 5  | Hose                  |
| 6  | Connecting plate      |
| 7  | Sealing element       |
| 8  | Restriction           |
| 10 | Seal                  |
| 11 | Seal with restriction |

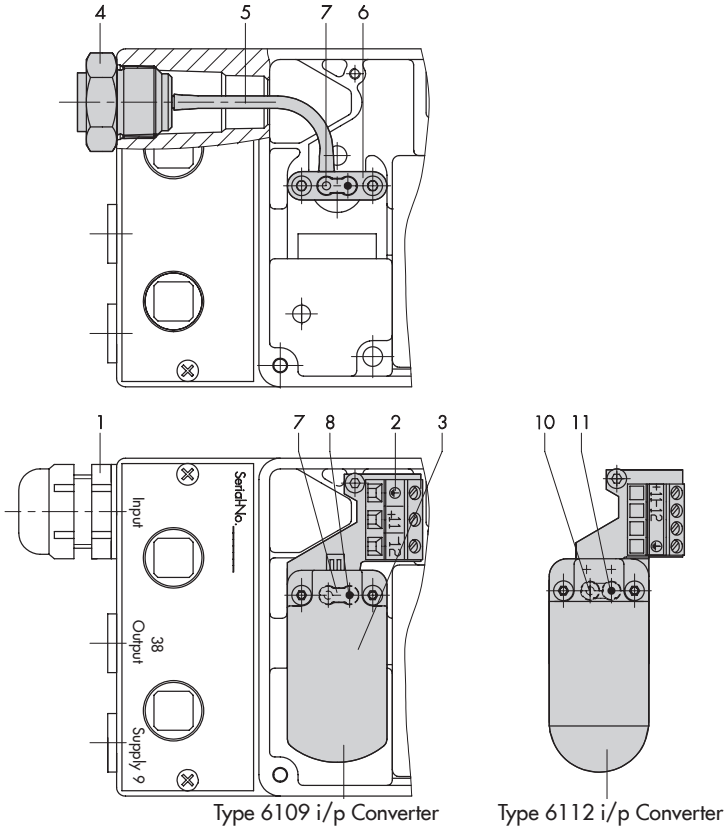

Fig. 13: Converting the positioner

## 9 Accessories, mounting parts and conversion kits

Accessories – Mounting parts	Order no.
Range spring 1	1190-0736
Range spring 2	1190-0737
Range spring 3	1190-0738
Lever I	1690-6469
Lever extension	1400-6716
Pressure gauge attachment, device index <b>.02</b> and higher	1400-6718
Pressure gauge attachment, device index <b>.03</b> and higher	1400-6950
Pressure gauge attachment (copper-free), device index <b>.02</b> and higher	1400-6719
Pressure gauge attachment (copper-free), device index <b>.03</b> and higher	1400-6951
Mounting unit for valves with cast yoke according to NAMUR	1400-5745
Valves with rod-type yoke according to NAMUR for 18 to 35 mm rod diameter	1400-5745 and 1400-5342
Assortment of spare parts including gaskets and diaphragms	1400-6792
Assortment of spare parts including gasket, diaphragms and pneumatic parts (for devices with device index <b>.02</b> and higher)	1402-0040
Upgrade to degree of protection IP 65: Venting over check valve	1790-7408

Required input signal (reference variable)	Required i/p module Type (order no.)	Additional conversion kit (device index <b>.03</b> and higher) Order no.
4 to 20 mA	6109-0010	1400-6797
0 to 20 mA	6112-002110	1400-6798
1 to 5 mA	6112-003110	1400-6798

## 10 Dimensions in mm

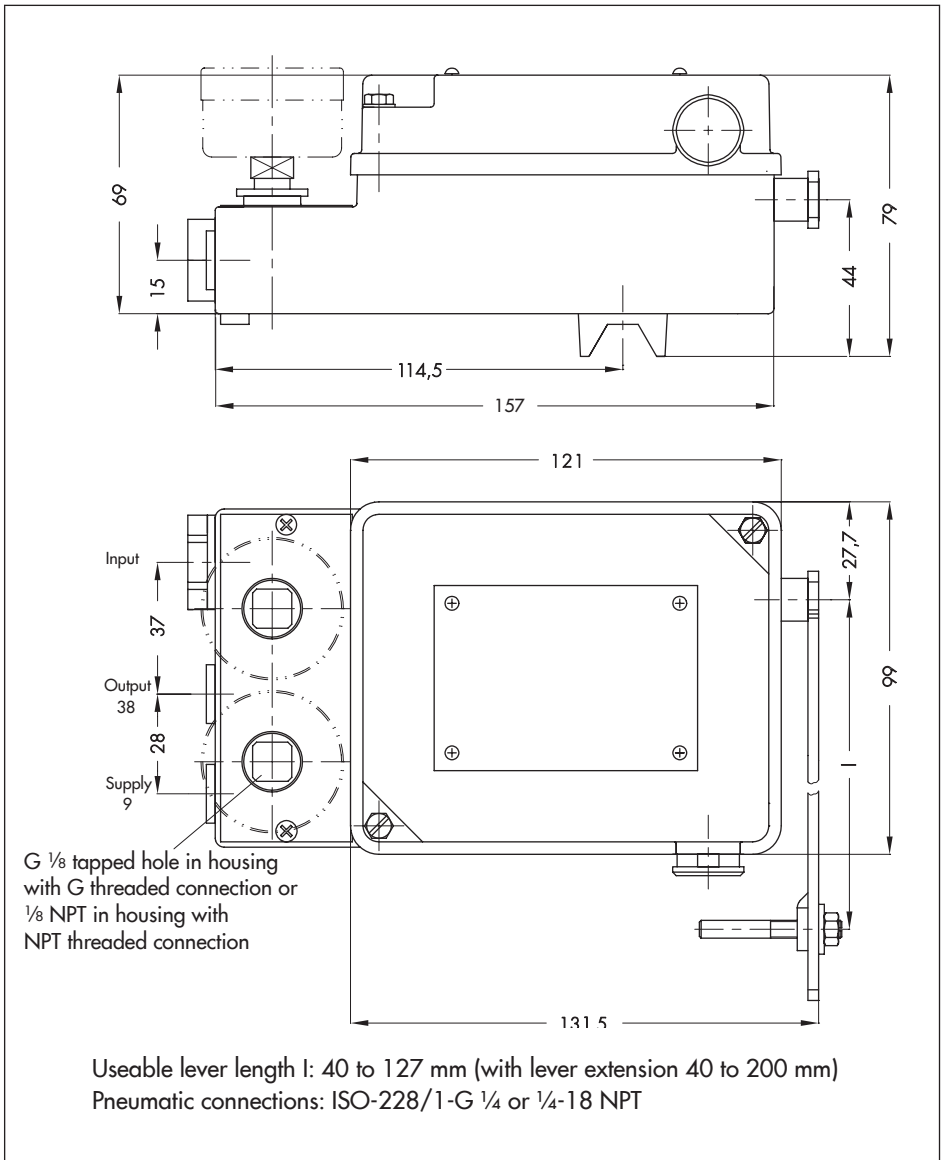



SAMSON AG · MESS- UND REGELTECHNIK  
Weismüllerstraße 3 · 60314 Frankfurt am Main, Germany  
Phone: +49 69 4009-0 · Fax: +49 69 4009-1507  
samson@samson.de · www.samson.de

**EB 8359-1 EN**

2017-05-03 · English