

# Series 3730 Electropneumatic Positioner Type 3730-3 ESD Version



With HART<sup>®</sup> communication

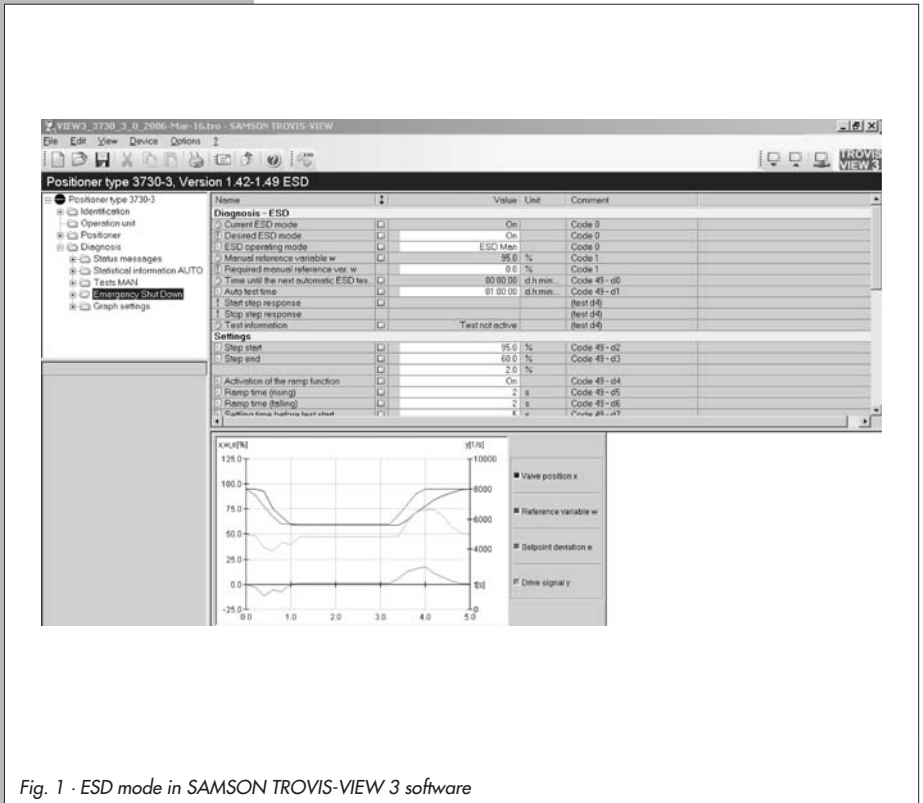

Fig. 1 · ESD mode in SAMSON TROVIS-VIEW 3 software

## Mounting and Operating Instructions

**EB 8388-1 EN**

Firmware version 1.4x

Edition November 2006

Contents

<b>1</b>	<b>Description</b> . . . . .	<b>3</b>
1.1	General . . . . .	3
1.2	ESD functions . . . . .	4
1.3	Presetting the positioner. . . . .	5
1.3.1	Converting TROVIS-VIEW 3. . . . .	5
1.3.2	Unlocking the positioner . . . . .	6
1.3.3	Printing the diagnostic/ESD log . . . . .	7
<b>2</b>	<b>ESD functions</b> . . . . .	<b>8</b>
2.1	Changing ESD parameters and starting the partial stroke test . . . . .	12
2.1.1	On-site operation . . . . .	13
2.2	Analyzing measured data . . . . .	13
2.2.1	Condensed state/Fault alarm output . . . . .	14
2.3	Measured data . . . . .	15
2.4	Resetting ESD . . . . .	15
2.5	List of ESD parameters. . . . .	16
<b>3</b>	<b>EXPERT<sup>®</sup> test functions</b> . . . . .	<b>19</b>
<b>4</b>	<b>Notes on applications.</b> . . . . .	<b>20</b>

## 1 Description

The **Type 3730-3 Positioner in ESD version** is based on the Type 3730-3 Positioner with HART® Communication.

These mounting and operating instructions, EB 8388-1 EN, supplement EB 8384-3 EN and focus on the ESD functions.

Technical data, attachment, electrical and pneumatic connections as well as operation and the standard EXPERT valve diagnostics are dealt with in Mounting and Operating Instructions **EB 8384-3 EN**.

---

### **Note!**

*The optional external position sensor cannot be used with the Type 3730-3 Positioner in ESD version.*

---

Extended EXPERT+ valve diagnostics are described in **EB 8388 EN**. By default, all positioners in ESD version include the EXPERT+ valve diagnostic functions.

---

### **Note!**

*Positioners delivered not mounted on an actuator are configured with the default settings, which means that the ESD functions are not activated.*

*After mounting the positioner on a safety shut-off valve and starting it up, switch the positioner to **ESD mode** to allow it to perform the safety functions (for required settings and instructions, see section 2 and **EB 8384-3 EN**).*

---

## 1.1 General

### **Note!**

*When the **ESD function is active**, the positioner keeps the attached valve to a set position, e.g. open. The valve does not perform any control tasks anymore.*

*In **AUTO** operating mode, the positioner can be used to control the attached valve.*

---

ESD (Emergency ShutDown) is a positioner function with extended firmware and partial stroke testing for the predictive, status-oriented detection of malfunctions in pneumatic shut-off valves in safety instrumented systems (SIS).

As a result, the probability of failure on demand (PFD) can be reduced and maintenance intervals can be extended.

All testing and diagnostic functions are completely integrated into the positioner. The measured data and test results are collected and stored in the positioner.

Partial stroke tests can be started and cancelled either manually at any time (on site or using an engineering tool) or automatically according to a certain schedule.

A test status is determined at the end of a partial stroke test, which allows operators to directly see whether the test has been completed successfully or not. When the test has not been completed successfully, possible causes of the fault are given. Apart from being indicated on the positioner's display or in the engineering tool used, the test status is also issued at the fault alarm output.

## Operation

The positioner can be operated on site using the rotary pushbutton (see section 2.1.1 "On-site operation"). Alarms are indicated on the LCD and issued over the fault alarm output (condensed status).

The **TROVIS-VIEW 3** software allows for convenient operation when communicating through the SAMSON SSP interface protocol. Thanks to DD and the FDT/DTM concept, the ESD functions can easily be integrated into the process control system or as-set management system.

The instructions concerning operation in the following sections refer to operation with TROVIS-VIEW 3.

---

**Note!** All parameter settings entered in the user interface need to be downloaded to the positioner to become effective.

---

## 1.2 ESD functions

### ESD mode

In ESD mode, the safety shut-off valve is moved to a specific set point within its working range. The valve does not perform any control tasks anymore. The valve is fully closed in case of an emergency.

In its basic setting, the positioner behaves similar to a solenoid valve, which keeps the attached valve to a set position, e.g. open.

For test purposes, the partial stroke test can either be started manually (ESD Man) or triggered automatically according to schedule (ESD Auto).

### Partial stroke test

The partial stroke test integrated into the positioner can prevent a normally open valve or a valve in its end position from seizing up or getting jammed.

As the course of the partial stroke test is plotted, the dynamic control response can also be analyzed.

During the test, the valve is moved out of the end position or from a start value either in steps or in a ramp function until it reaches a defined final value. Then, the valve is moved back again to its initial position.

The partial stroke test is performed, for example between 10 and 15 % of the rated travel, starting from the end position while the plant is running, yet without disrupting plant operation. The start and stop values for the partial stroke test can be configured by the user.

The following test cancellation conditions provide additional protection against the valve slamming shut and moving past the final value:

- ▶ Valve position  $x$
- ▶ Drive signal  $y$
- ▶ Maximum test time is exceeded
- ▶ Tolerance range exceeded

The course of the *controlled variable  $x$ , reference variable  $w$ , setpoint deviation  $e$ , and drive signal  $y$*  parameters is saved in the positioner, assigned to the operating hours counter.

The *dead time,  $T63$ ,  $T98$ , overshooting, rise time, and response time* parameters of a step response test are analyzed separately

for the increasing and decreasing characteristic.

The analyses of the last three partial stroke tests are saved in the positioner with the associated time stamp.

The EXPERT+ test functions **Data logger** and **Hysteresis test** to detect friction changes are also available in ESD mode (see section 3 and EB 8388 EN).

#### Note!

The valve position is used as the valve travel condition by the data logger of positioners in ESD version.

## 1.3 Presetting the positioner

### 1.3.1 Converting TROVIS-VIEW 3

The TROVIS-VIEW 3 version must match the software version of the positioner.

When establishing communication or exchanging data between the PC and the positioner, the firmware version is checked automatically and the appropriate TROVIS-VIEW 3 module is loaded.

To adapt the TROVIS-VIEW 3 version before transmitting data proceed as follows:

1. In the File menu, select Convert.  
A window listing all available firmware versions is opened.
2. Select "Version 1.xx-1.xx ESD".



3. Confirm selection with OK.  
TROVIS-VIEW 3 switches to the user interface for the positioner in ESD version.

## 1.3.2 Unlocking the positioner

To prevent unauthorized access, the positioner settings cannot be changed unless the valid ESD code has been entered.

The positioner needs to be unlocked separately for on-site operation and operation through TROVIS-VIEW depending on the operating mode.

The ESD code can be found on page 21. Remove the code or make it unreadable to prevent unauthorized use.

### Entering the code on the positioner



Default: OFF

Turn  → Code 3

Press .

Turn  → ON

Press . Display shows: 0

Turn  → ESD code

Press . Display shows: ON, 

### Entering the code in TROVIS-VIEW 3

1. In the Device menu, select ESD enabling code.  
TROVIS-VIEW 3 establishes a connection with the positioner.
2. Enter the code in the Value field.

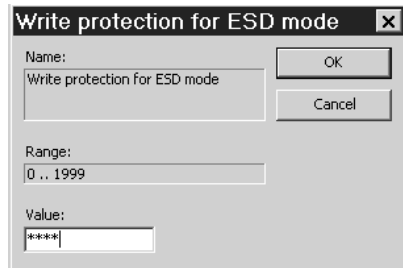

3. Confirm selection with OK.

### 1.3.3 Printing the diagnostic/ESD log

The Print command allows you to print out a diagnostic log of individual tests or the entire diagnosis.

The diagnostic log includes a title page and a list of all the data points including all their values and properties.

The title page contains all key information for clear identification of the printed log (device type, file name, time and date of creation, time and date of the last change and TROVIS-VIEW version).

Select Print in the File menu to add further information.

1. In the File menu, select Print Options to choose the scope of the diagnostic log.

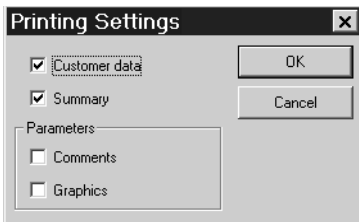

After installing/updating the TROVIS-VIEW software, customer data (Customer data in the Edit menu) and summary (table of contents) are listed in the diagnostic log by default.

Check the check boxes for the Comments and Graphics options to add these options to the diagnostic log.

2. Right-click the [Diagnosis] folder or the required subfolder and select Print from

the context-sensitive menu to print the diagnostic log.

The printout contains the contents of the folder and its subfolders.

## 2 ESD functions

### TROVIS-VIEW 3: [Diagnosis > Emergency Shut Down]

In TROVIS-VIEW 3, the functions of the positioner in ESD mode are listed in the [Diagnosis] folder under Emergency Shut Down. They include:

- ▶ Activating/deactivating ESD mode and starting the partial stroke test
- ▶ Setting the parameters for partial stroke testing
- ▶ Defining the cancellation conditions for partial stroke testing

**Note!**

Instructions on how to change parameters and start the partial stroke test can be found in section 2.1 "Changing ESD parameters and starting the partial stroke test".

### ESD mode

ESD mode is active if the *Target mode* parameter in the [Positioner] folder under Operating mode is set to "Emergency Shut Down" and *Desired ESD mode* parameter in the [Diagnosis] folder under Emergency Shut Down is set to "On".

In ESD mode, the safety shut-off valve is specifically moved to the set point of the valve working range (parameter: *Required manual reference variable w*).

The positioner behaves similar to a solenoid valve, which keeps the attached valve to a set position, e.g. open. The valve does not perform any control tasks anymore.

The current valve position is indicated under *Manual reference variable w*.

The *ESD operating mode* parameter sets the conditions for starting the partial stroke test:

### Test started manually (ESD Man)

*ESD operating mode* parameter = ESD Man

Partial stroke testing begins when triggered by the *Start step response* parameter. Otherwise, the valve remains in the position defined by the *Required manual reference variable w* parameter.

**Changes to the parameters can only be made in ESD Man mode.**

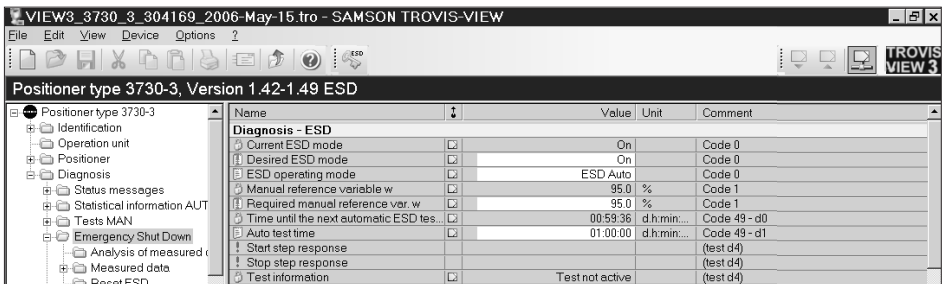

**Test started automatically according to schedule (ESD Auto)**

ESD operating mode parameter = "ESD Auto"

Partial stroke tests are conducted at regular intervals. The *Time until the next automatic ESD test* parameter indicates when the next test is scheduled (countdown).

**Partial stroke test**

The course of the partial stroke test depends on the parameters listed under **Settings** in TROVIS-VIEW 3. Depending on the parameter settings, the partial stroke test is conducted either in steps or in a ramp function of the valve position (see Fig. 2).

After being triggered, the test does not start until the *Settling time before test start* ( $t_1$ ) has elapsed. This waiting period ensures that the valve has reached the position defined by the *Step start* parameter (pos. 2, see Fig. 2) before the test starts.

Starting from the *Step start* position (pos. 2), the valve moves to the defined end position (*Step end* parameter, pos. 3). The valve remains in this position for the time defined by the *Delay time after step* ( $t_2$ ) before performing a second step change in the opposite direction from *Step end* (pos. 3) to *Step start* (pos. 2).

After the *Delay time after step* ( $t_2$ ) has elapsed, the valve is moved back to its initial position (= *Required manual reference variable w*, pos. 1)

The *Step tolerance limit* (range: 0.1 to 10.0 %) sets the permissible tolerance limit for the step's start and end values.

The *Scan rate* (range: 0.2 to 30.0 s) defines the interval at which the measured values are recorded during the test. The positioner stores a maximum of 100 measured values per measured variable (valve position  $x$ , reference variable  $w$ , setpoint deviation  $e$ , drive signal  $y$  and the time when they were recorded). After 100 measured values per

VIEW3\_3730\_3\_0\_2006-May-15.tro - SAMSON TROVIS-VIEW

File Edit View Device Options ?

Positioner type 3730-3, Version 1.42-1.49 ESD

Name	Value	Unit	Comment
<b>Settings</b>			
<input type="checkbox"/> Step start	10.0	%	Code 49-d2
<input type="checkbox"/> Step end	90.0	%	Code 49-d3
<input type="checkbox"/> Delay time after step	2.0	%	
<input type="checkbox"/> Activation of the ramp function	Off		Code 49-d4
<input type="checkbox"/> Ramp time (rising)	0	s	Code 49-d5
<input type="checkbox"/> Ramp time (falling)	0	s	Code 49-d6
<input type="checkbox"/> Settling time before test start	10	s	Code 49-d7
<input type="checkbox"/> Delay time after step	2.0	s	Code 49-d8
<input type="checkbox"/> Scan rate	0.2	s	Code 49-d9
<input type="checkbox"/> Recommended sampling time	—	s	
<input type="checkbox"/> Duration of the test	—	s	
<input type="checkbox"/> Max. test duration	120	s	
<input type="checkbox"/> Fault alarm output	Normal error message		
<b>Cancellation conditions</b>			
<input type="checkbox"/> Activation x control	Off		Code 49-E0
<input type="checkbox"/> x control value	0.0	%	Code 49-E1
<input type="checkbox"/> Activation y control	Off		Code 49-E2
<input type="checkbox"/> y control value	0	1/s	Code 49-E3
<input type="checkbox"/> Activation tolerance band control	Off		Code 49-E5
<input type="checkbox"/> ESD Tolerance band	5.0	%	Code 49-E6
<b>Display</b>			
<input type="checkbox"/> Progress flag	—	%	
<input type="checkbox"/> Minimum value y control	—	1/s	Code 49-E4

measured variable have been stored, the logging is stopped. However, the test is still completed. The *Measured data storage out of memory alarm* is generated. The *Recommended sampling time*, which should not be shorter, if at all possible, is calculated from the *Duration of the test*.

The **Display** section in TROVIS-VIEW 3 shows the *Progress flag* in percent.

**1. Step response function, Fig. 2 left**

The step response function is activated when the *Activation of the ramp function* parameter is set to "Off".

The valve is moved in steps to the *Step end* position (pos. 3) during the first half of the test and to the *Step start* position (pos. 2) during the second half of the test.

**2. Ramp function, Fig. 2 right**

The ramp function is active when the *Activation of the ramp function* parameter is set to "On".

**Note!**

*A step before the partial stroke test can be prevented by allocating the value of the manual reference variable w to the Step start parameter.*

The valve is moved to the *Step end* (pos. 3) and *Step start* (pos. 2) positions with fixed velocities ( $v_1$  and  $v_2$ ) set by the *Ramp time (falling)* and *Ramp time (rising)* parameters.

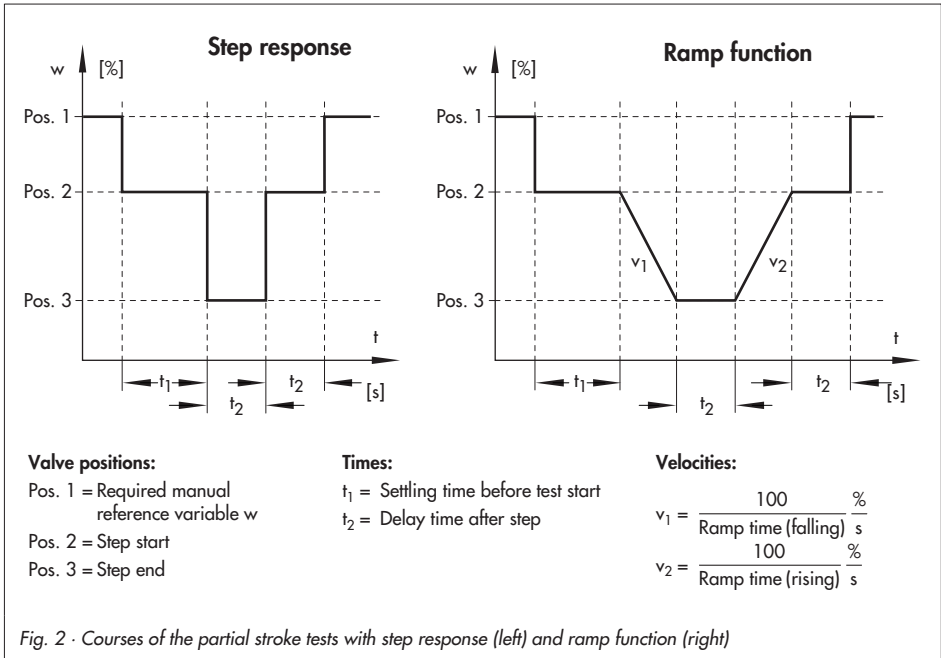

The ramp time specifies the time required by the valve to move through the travel range 100 to 0 % (falling) and 0 to 100 % (rising).

**Note!**

*Times for the Ramp time (falling/rising) are determined during initialization of the positioner. These times are not to be exceeded when setting the parameters for the partial stroke test with ramp function.*

**Cancellation conditions**

To ensure that the running process is not disrupted and that the shut-off valve does not slam shut unintentionally, it is advisable to define conditions that cause the positioner to cancel an active partial stroke test. The positioner issues an alarm when a test has been cancelled (see section 2.2).

Possible cancellation conditions are:

- ▶ **Max. test duration:** The test is cancelled when the maximum permissible test duration (range: 30.0 to 3000.0 s) is exceeded.
- ▶ **x control value:** The test is cancelled when the value falls below the adjusted valve position (range: -10 to 110 %).

The condition is only active when *Activation x control* is set to "On".

- ▶ **y control value:** The test is cancelled when the value falls below the adjusted drive signal (range: 0 to 9999 1/s).

The condition is only active when *Activation y control* is set to "On".

Monitoring the drive signal y only makes sense when the partial stroke test is performed as a ramp function because the y cancellation condition is always met with the step response function.

A suitable y control value can be determined using the last performed partial stroke test. After the test is completed, the lowest drive signal value recorded by the test is displayed under the Minimum value y control (in TROVIS-VIEW 3 under **Display**). This value should be used as a reference value with a 15 % tolerance:  $y\ control\ value \approx 0.85 \times Minimum\ value\ y\ control$ .

- ▶ **ESD tolerance band:** The test is cancelled when the deviation of the valve position (in relation to the step height) exceeds the adjusted value (range: 0.1 to 100.0 %).

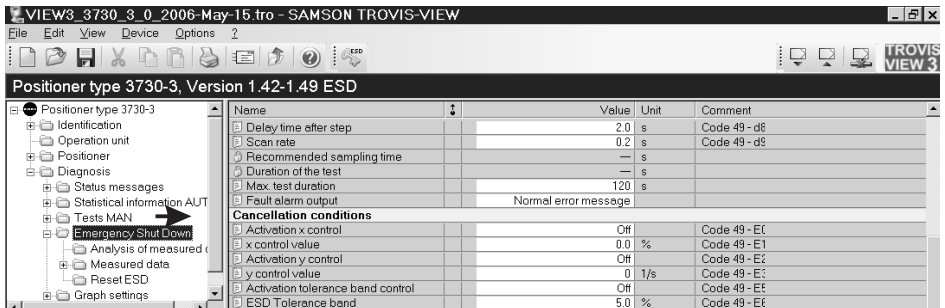

The condition is only active when *Activation tolerance band control* is set to "On".

During the course of the test, the following parameters are changed as specified:

- ▶ Lower x-range value (Code 8): 0 %
- ▶ Upper x-range value (Code 9): 100 %
- ▶ w-ramp OPEN/CLOSED (Codes 21/22): variable

The data can be reset in the [Status messages] folder under Reset.

## 2.1 Changing ESD parameters and starting the partial stroke test

To change ESD parameters using TROVIS-VIEW 3, proceed as follows:

1. Enter ESD code (see section 1.3.2).  
If the positioner is not operated and no data are modified by an operating program (DTM or TROVIS-VIEW 3) for 15 minutes, the positioner is locked again. To make additional changes, the ESD code needs to be entered again.
2. In the [Positioner] folder under Operating mode, set the *Target mode* parameter to "Emergency Shut Down".
3. In the [Emergency Shut Down] folder, set the *ESD operating mode* parameter to "On".
4. In the [Emergency Shut Down] folder, select the *ESD operating mode* parameter to "ESD Man".  
The positioner alternately displays "ESd", the *Manual reference variable w*, and "MAN".

5. Set the parameters in the [Emergency Shut Down] folder as desired.

The further course of action depends on whether the test is to be started manually (→ Test started manually) or performed automatically at certain intervals according to schedule (→ Test started automatically according to schedule).

### Test started manually

6. Right-click the *Start step response* parameter and select Execute from the context-sensitive menu.
7. The test will start after the "Warning. During test start the control valve departs from its current position at full travel! Execute test?" message has been confirmed.  
The positioner displays "tEst d4".

### Test started automatically according to schedule

6. Set the *Auto test time* parameter to the desired interval at which the partial stroke test is to be repeated.  
If *Auto test time* is set to "0", the test is not performed.
7. In *ESD operating mode*, select "ESD Auto".  
The test is performed at the *Auto test time* interval. The first test is started when the interval has elapsed for the first time.  
After switching the operating mode and returning to ESD Auto mode, the *Auto test time* interval starts again.  
The *Time until the next automatic ESD*

test parameter indicates the time that remains until the next test is started. The positioner alternately displays “ESd”, the *Manual reference variable w*, and “MAN”.

At the end of the test, the *Status of ESD test* indicates whether the partial stroke test has been completed successfully or not (see section 2.2 “Analyzing measured data”).

### 2.1.1 On-site operation

**Note!**

*Parameters can only be changed in positioners in ESD version after entering the enabling ESD code (Code 3). You can only change the reading direction (Code 2) if the ESD code has not been entered.*

The described settings can be adjusted directly on the positioner on site:

- ▶ Entering the ESD code using Code 3
- ▶ Selecting the ESD Man/ESD Auto operating mode using Code 0

The following modifications can only be performed when the positioner is in ESD Man operating mode:

- ▶ Setting the reference variable *Manual w* using Code 1
- ▶ Setting the ESD parameters using Code 49 (see section 2.5)

**Starting the partial stroke test:**

1. Select operating mode ESD using Code 0.

2. In operating mode ESD, select *ESD Man* mode, holding down the rotary pushbutton until the countdown has elapsed. The test will start.

**Note!** Section 2.5 lists the available ESD parameters.

## 2.2 Analyzing measured data

**TROVIS-VIEW 3:** [Diagnosis > Emergency Shut Down > Analysis of measured data]

Analyses of the last three partial stroke tests completed are saved in the positioner with a time stamp.

If the test has not been completed successfully, the reason why the test was cancelled is indicated under “Maintenance alarm”.

The positioner indicates “ESd tEst FAIL”. Possible reasons for cancellation depending on the defined cancellation conditions are:

- ▶ *x cancellation:* The valve position fell below the *x control value*.

Name	Value	Unit
<b>Diagnosis - ESD - Saved analyses</b>		
<b>Current test</b>		
<input checked="" type="checkbox"/> Time stamp for this test	00:35:07	d,h:min:sec
<input checked="" type="checkbox"/> Overshoot (increasing)	0.0	%
<input checked="" type="checkbox"/> Dead time (increasing)	0.6	s
<input checked="" type="checkbox"/> T63 (increasing)	0.6	s
<input checked="" type="checkbox"/> T98 (increasing)	2.0	s
<input checked="" type="checkbox"/> Rise time (increasing)	2.0	s
<input checked="" type="checkbox"/> Settling time (increasing)	2.2	s
<input checked="" type="checkbox"/> Overshoot (decreasing)	0.0	%
<input checked="" type="checkbox"/> Dead time (decreasing)	1.2	s
<input checked="" type="checkbox"/> T63 (decreasing)	1.6	s
<input checked="" type="checkbox"/> T98 (decreasing)	1.6	s
<input checked="" type="checkbox"/> Rise time (decreasing)	1.6	s
<input checked="" type="checkbox"/> Settling time (decreasing)	1.6	s
<b>Test status (of current test)</b>		
<input checked="" type="checkbox"/> No test available / Test man. canceled	OK	No message
<input checked="" type="checkbox"/> x cancellation	OK	No message
<input checked="" type="checkbox"/> y cancellation	OK	No message
<input checked="" type="checkbox"/> Tolerance band exceeded	OK	No message
<input checked="" type="checkbox"/> Max. test time exceeded	OK	No message
<input checked="" type="checkbox"/> Test start in wrong operating mode	OK	No message
<input checked="" type="checkbox"/> Measured data storage out of memory	OK	No message
<input checked="" type="checkbox"/> Aborted by solenoid valve	OK	No message
<input checked="" type="checkbox"/> Supply pressure / friction	OK	No message

- ▶ *y* cancellation: The drive signal fell below the *y* control value.
- ▶ *Tolerance band exceeded*: The deviation of the valve position exceeded the ESD tolerance band.
- ▶ *Max. test time exceeded*: The test was not completed within the specified period of time.

Further error messages include:

- ▶ *Test manually cancelled*: The test has been manually cancelled.
- ▶ *Measured data storage out of memory*: The scan rate has been selected too low. After 100 measured data per measured variable have been recorded, the logging stops. However, the test is continued.
- ▶ *Aborted by solenoid valve*: The test was cancelled by the solenoid valve being triggered.
- ▶ *Supply pressure/friction*: An insufficient supply pressure or excessive friction occurred during the test.

When a partial stroke test has been completed successfully, analyzed parameters are displayed separately for the increasing and the decreasing characteristic:

- ▶ *Overshoot* (relative to step change, [%])
- ▶ *Dead time* [s]
- ▶ *T63* [s]
- ▶ *T98* [s]
- ▶ *Rise time* [s]
- ▶ *Settling time* [s]

## 2.2.1 Condensed state/Fault alarm output

The *Fault alarm output* parameter allows you to define which type of alarm is issued by the hardware fault alarm output (normal error message and/or ESD status).

- ▶ **Normal error message**: EXPERT/EXPERT+ condensed state (see EB 8384-3 EN, Code 32 and 33)
- ▶ **ESD status**: ESD function status
- ▶ **Normal error message and ESD status**: ESD function status plus EXPERT/EXPERT+ condensed state

If a set ESD status (partial stroke test not successful) is to be included in the **condensed state**, go to the [Positioner] folder under [Error control > Classification report > Extended > Emergency Shut Down] and assign a classification. The following classifications (also see section 6.3 in **EB 8384-3 EN**, and section 4 in **EB 8388 EN**) are available:

- ▶ Maintenance alarm
- ▶ Maintenance required
- ▶ Maintenance demanded
- ▶ No message [default]

When the default value “No message” is set, the ESD status is not included in the condensed state.

---

### Note!

*The Fault alarm output parameter must be set to “ESD status” or “Normal error message and ESD status” to allow the ESD status to be indicated at the fault alarm output.*

---

## 2.3 Measured data

**TROVIS-VIEW 3:** [Diagnosis > Emergency Shut Down > Measured data]

The following parameters are measured during the partial stroke test:

- ▶ *Valve position  $x$*
- ▶ *Reference variable  $w$*
- ▶ *Setpoint deviation  $e$*
- ▶ *Drive signal  $y$*
- ▶ *Time*

These parameters are saved in a FIFO memory with a capacity of 100 measured values. The last 100 measured values of the parameters determined during the partial stroke test are listed in the [Measured data] folder.

## 2.4 Resetting ESD

**TROVIS-VIEW 3:** [Diagnosis > Emergency Shut Down > Reset ESD]

Using the *Reset ESD* parameter, the parameters of the ESD functions and the data logger are reset to their default values. Any recorded measured values, error messages, and data logger data are deleted.

---

**Note!** *After resetting the parameter, the positioner is in the MAN operating mode. The ESD mode needs to be reactivated.*

---

## 2.5 List of ESD parameters

The ESD parameters can be found in the positioner under **Code 49**.

Code No.	Parameters – display, Values [default settings]	Description
<b>Note!</b>	The positioner settings cannot be changed unless the ESD code has been entered under Code 3, see section 1.3.2. Modifications in Codes 1 and 49 can only be made when the positioner is in ESD Man operating mode.	
<b>0</b>	<b>Operating mode</b> MAN – AUtO – SAFE – ESd (→ ESd Man/ESd Auto) – ESC, [MAN]	AUtO: Automatic operation MAN: Manual operation SAFE: Fail-safe position ESd Man: Manual ESD mode Starting the partial stroke test manually, see section 2.1.1 ESd Auto: Automatic ESD mode
<b>1</b>	<b>Manual w</b> 0 to 100 [0] % of the nominal range	Adjust the manual set point with the rotary pushbutton. The current travel/angle is displayed in % when the positioner is initialized. Otherwise the sensor position in relation to the central axis is indicated in degrees °.
<b>3</b>	<b>Unlocking the positioner, configuration</b> OFF – ON – ESC, [OFF]	The positioner settings cannot be changed on site unless the ESD code has been entered.
<b>49</b>	<b>ESD parameters</b>	
	d0 Time until the next automatic ESD test Display only.	Time remaining until the next ESD test is started.
	d1 Auto test time 1 to 56280 h, [1 h]	Desired time for repeating an ESD test
	d2 Step start 0.0 to 100.0 %, [95.0 %]	Start value for step response
	d3 Step end 0.0 to 100.0 %, [90.0 %]	End value for step response
	d4 Activation of the ramp function On – Off, [Off]	Activates or deactivates the ramp function.
	d5 Ramp time (rising) 0 to 1000 s, [value determined during initialization, minimum value: 15 s]	Ramp time for 0 to 100 % (rising) of the ramp function. A suitable value is determined during initialization; if possible, make sure the ramp time does not fall below this value.

Code No.	Parameters – display, Values [default settings]	Description
49	d6 Ramp time (falling) 0 to 1000 s, [value determined during initialization, minimum value: 15 s]	Ramp time for 100 to 0 % (falling) of the ramp function. A suitable value is determined during initialization; if possible, make sure the ramp time does not fall below this value.
	d7 Settling time before test start 1 to 240 s, [10 s]	Delay time before test is started to ensure that the valve can be moved to the step start position safely ( $t_1$ , Fig. 2)
	d8 Delay time after step 1.0 to 240.0 s, [2.0 s]	Delay time between the first and the second step change ( $t_2$ , Fig. 2)
	d9 Scan rate 0.2 to 30.0 s, [0.2 s]	Scan rate of step response measurement
	E0 Activation x control On – Off, [Off]	Activates or deactivates x monitoring
	E1 x control value –10.0 to 110.0 %, [0.0 %]	The test is cancelled when the valve position falls below this value.
	E2 Activation y control On – Off, [Off]	Activates or deactivates y monitoring Activation only makes sense when the partial stroke test is performed as a ramp function.
	E3 y control value 0 to 9999 1/s, [0 1/s]	The test is cancelled when the drive signal falls below this value.
	E4 Minimum value y control Display only.	Indicates the smallest value that y assumed during the last ESD test This parameter can be used to determine the limit value for y monitoring (y control value).
E5 Activation tolerance band control On – Off, [Off]	Activates or deactivates ESD tolerance band monitoring	
E6 ESD tolerance band 0.1 to 100.0 %, [5.0 %]	The test is cancelled when the deviation of the valve position exceeds this percentage.	
E7 Max. test duration 30.0 to 3000.0 s, [120.0 s]	Maximum test duration; the test is cancelled in any case when this period has elapsed.	
E8 – unassigned –		
E9 Reset ESD	All ESD parameters are reset to their default values. All measured data are deleted.	

Code No.	Parameters – display, Values [default settings]	Description
<b>49</b>	<b>ESD error codes (display only)</b>	
	F0 No test available	No test available or test cancelled manually
	F1 Test OK	
	F2 x cancellation	Test cancelled by the x cancellation function
	F3 y cancellation	Test cancelled by the y cancellation function
	F4 Tolerance band exceeded	The test has been cancelled. x values outside the tolerance band occurred
	F5 Max. test time exceeded	Test not completed within the maximum test duration and therefore cancelled
	F6 Test manually cancelled	Test cancelled by the operator
	F7 Measured data storage out of memory	Storage for measured values out of memory. After 100 measured values per measured variable, the logging is stopped. However, the test is still continued.
	F8 Aborted by solenoid valve	Test cancelled by the solenoid valve being triggered
	F9 Supply pressure/ friction	Test cancelled due to insufficient supply pressure or excessive friction

### 3 EXPERT+ test functions

By default, all positioners in ESD version include the EXPERT+ valve diagnostic functions. However, the positioner's operating mode determines which diagnostic functions are available.

#### Presetting actuator and valve data

To use the integrated EXPERT+ functions, certain details on the actuator and valve used need to be entered, including:

- ▶ *Model* parameter under [Identification > Positioner > Actuator]  
Options: single acting, double acting  
Default: single acting
- ▶ *Booster* parameter under [Identification > Positioner > Actuator]  
Options: not present, present  
Default: not present
- ▶ *Stuffing box* parameter under [Identification > Positioner > Valve]  
Options: self-adjusting, adjustable packing, bellows seal  
Default: self-adjusting

If actuator and valve correspond to the default values, no further settings need to be entered.

Operating mode (Code 0)	EXPERT+ functions	Test requirements
AUTO	As in EB 8388 EN	
MAN		
<b>ESD mode</b>		
ESD Man	Data logger/ Statistical information Auto <b>TROVIS-VIEW 3:</b> [Diagnosis > Statistical information AUTO > Data logger]	For test description, see <b>EB 8388 EN</b> , section 2.1 <b>Note!</b> The valve position is used as the valve travel condition by the data logger of positioners in ESD version.
	Drive signal y Hysteresis/ Statistical information Auto <b>TROVIS-VIEW 3:</b> [Diagnosis > Statistical information AUTO > Drive signal diagram > Hysteresis]	For test description and requirements, see <b>EB 8388 EN</b> , section 2.5.2 Actuator and valve data need to be preset, see above
ESD Auto	Data logger/ Statistical information Auto <b>TROVIS-VIEW 3:</b> [Diagnosis > Statistical information AUTO > Data logger]	For test description, see <b>EB 8388 EN</b> , section 2.1 <b>Note!</b> The valve position is used as the valve travel condition by the data logger of positioners in ESD version.

## 4 Notes on applications

Usually, shut-off valves in a safety-instrumented system are equipped with a solenoid valve for emergency shutdown.

Several setups are possible when integrating the Type 3730-3 Positioner in ESD version into the automation system:

In Fig. 3, the positioner replaces the solenoid valve.

The safety function is triggered by the safety-related control; accordingly, the solenoid valve and the limit switch are connected to it.

To read the additional diagnostic information and define set points, it is advisable to integrate the positioner into the control system and the asset management system.

As shown in Fig. 4, no solenoid valve is required since the positioner, similar to the solenoid valve, is certified for safe shutdown. When the energy supply fails, the pneumatic output is safely vented.

In this setup, the positioner's 4 to 20 mA signal is applied to the safety-related programmable logic controller. The HART® protocol is used for connection to the asset management system.

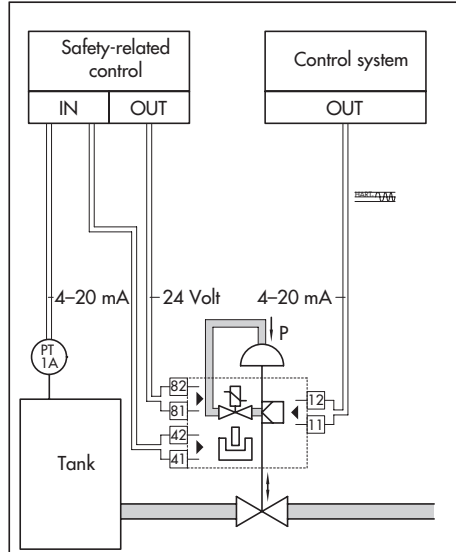

Fig. 3 · Positioner replaces solenoid valve

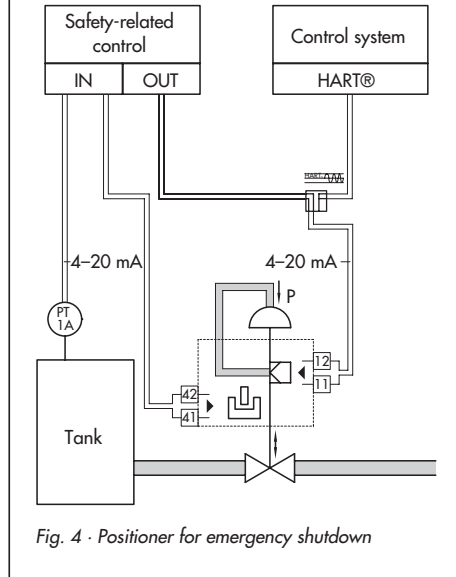
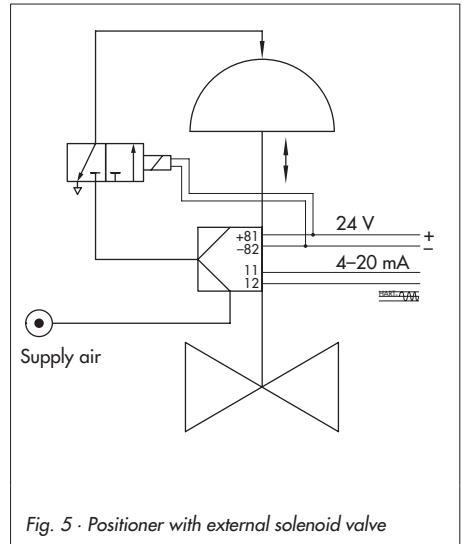

Fig. 4 · Positioner for emergency shutdown

Fig. 5 shows a special application. In this setup, the solenoid valve integrated into the positioner (terminals 81, 82) is used together with an existing external solenoid valve to trigger the data logger.



**ESD code**

1732







SAMSON AG · MESS- UND REGELTECHNIK  
Weismüllerstraße 3 · 60314 Frankfurt am Main · Germany  
Phone: +49 69 4009-0 · Fax: +49 69 4009-1507  
Internet: <http://www.samson.de>

**EB 8388-1 EN**

10-2002