

Fig. 1 · Media 05, indicating unit with differential pressure cell,
with valve block and pressure gauge (right)

Mounting and Operating Instructions

EB 9520 EN

Edition November 2010

Contents

1	Design and principle of operation.	5
2	Installation	6
2.1	Arrangement of instruments for liquid level measurement	6
2.2	Arrangement of instruments for flow rate measurement	6
2.3	Media 05 indicating unit	6
2.4	Differential pressure lines	8
2.5	Orifice plate assembly	8
3	Accessories.	9
3.1	Valve block	9
3.2	Shut-off and equalizing valves	10
3.3	Equalizing tanks	10
3.4	Accessories for connection	10
4	Start-up.	10
4.1	Flow rate measurement	10
4.2	Liquid level measurement	11
5	Operation.	11
5.1	Zero adjustment	11
5.2	Draining	12
5.3	Adjusting and modifying the measuring range	12
6	Version with limit switches	14
6.1	Electrical connection	14
6.2	Adjusting the alarm contacts	14
6.3	Retrofitting/replacing the contact unit	16
7	Dimensions in mm	18

WARNING!

Devices intended to measure gaseous oxygen are labeled



Oxygen! Keep free of oil and grease!

The manufacturer has cleaned and assembled all devices for oxygen service under special conditions. When replacing parts that come into contact with gaseous oxygen, e.g. range springs, wear appropriate gloves. When returning devices for oxygen service for repair, the sender assumes full responsibility that the devices are handled to meet all requirements stipulated by German specification BVG 7 or similar regulations until they are handed over to the manufacturer. Otherwise, SAMSON AG does not accept any responsibility.



General safety instructions

- ▶ *The device must be installed, started up and serviced by fully trained and qualified personnel only, observing the accepted industry codes and practices.*
Make sure employees or third persons are not exposed to any danger. All safety instructions and warnings in these mounting and operating instructions, particularly those concerning installation, start-up and maintenance, must be observed.
- ▶ *Any hazards that could be caused at the instrument by the medium and the operating pressure in the instrument are to be prevented by appropriate measures. Make sure that the instrument is only used where temperatures and operating pressure do not exceed the sizing data specified in the order.*
- ▶ *When mounted on vessels in which hazardous area conditions of Zone 0 are to be expected, the Media 05 Differential Pressure and Flow Meter without limit switches may be used to measure flammable gases and liquids provided that the operator observes the relevant regulations on the measurement of flammable gases and liquids of Zone 0. This means measuring instruments suitable for connection to Zone 0 may be installed provided that:*
 - 1) *The pipes connecting the instruments have been sized and installed according to the German Technical Regulations for Flammable Liquids TRbF 50 or*
 - 2) *Flame arresters or endurance burning flame arresters have been installed in the two measuring lines.*

Whether you have to install flame arresters or endurance burning flame arresters depends on the conditions on site. It is, however, preferable to install endurance burning flame arresters. You are required to contact the appropriate regulatory authority to agree on the necessary measures. Note that it is the operator's responsibility to meet the requirements specified in 1) and 2) and that SAMSON AG does not assume any responsibility if the operator fails to do so.

- ▶ *Proper shipping and appropriate storage are assumed.*
- ▶ **Note:** *Devices with the CE mark meet the requirements specified in the Directive 94/9/EC and the Directive 89/336/EEC. The Declaration of Conformity is available on request.*

Technical data

Media 05 Differential Pressure Meter											
Measuring range	mbar	0 to 60	0 to 100	0 to 160	0 to 250	0 to 400	0 to 600	0 to 1000	0 to 1600	0 to 2500	0 to 3600
Measuring span mbar	min. max.	40 to 60	60 to 100	100 to 160	160 to 250	250 to 400	400 to 600	600 to 1000	1000 to 1600	1600 to 2500	2500 to 3600
Nominal pressure	PN 50, overloadable on one side up to 50 bar										
Indicator	Scale 250°, scale length approx. 162 mm, division of scale 0 to 100 % linear or squared, for any linear measured quantities, for measured quantities acc. to equation, curve or table										
Performance	Characteristic linear to differential pressure, scale linear to tank contents										
Conforming error	$< \pm 2.5 \%$ ¹⁾ (including hysteresis)										
Sensitivity	< 0.5 %	< 0.25 %									
Effect of static pressure	< 0.03 % / 1 bar										
Limit switches	2 inductive alarm contacts A1 and A2 acc. to EN 60947-5-6										
Control circuit	Values corresponding to connected isolating switch amplifier e.g. KFA6-SR2-Ex2.W										
Proximity switch	SJ2-SN, when used for hazardous areas corresponding to PTB 00 ATEX 2049 X										
Switching accuracy	$\leq \pm 2 \%$										
Range of inversion, approx.	< 0.6 %										
Perm. ambient temperature	-40 to +80 °C · With oxygen -40 to +60 °C										
Perm. storage temperature	-40 to +100 °C										
Use with gaseous oxygen as the operating medium	Max. temperature: +60 °C · Max. oxygen pressure: 30 bar										
Degree of protection	IP 54 acc. to EN 60529										
Weight	Without SAMSON valve block: Approx. 2.6 kg With SAMSON valve block: Approx. 4.6 kg										
Materials											
Version	Standard version										
Housing	Brass (CW617N) or CrNi steel										
Measuring diaphragm and seals	ECO ²⁾										
Range springs, diaphragm plates, functional parts, lever	CrNi steel										
Indicating unit	Polycarbonate										

¹⁾ Based on the upper measuring range value · ²⁾ Other on request

NOTE: All pressures specified as gauge pressures. All errors and deviations in % of the adjusted measuring span.

1 Design and principle of operation

The Media 05 Differential Pressure and Flow Meter serves to measure and indicate the differential pressure or variables derived from the differential pressure of gases or liquids. For example, it is used for measuring the liquid level in pressure vessels, the differential pressure between flow and return flow, the pressure drops across valves and filters as well as the flow rate according to the differential pressure method.

The device consists of a differential pressure cell with a measuring diaphragm and range springs and an indicating unit including a pointer mechanism and a scale.

The differential pressure $\Delta p = p_1 - p_2$ produced by the orifice plate creates a force acting on the measuring diaphragm (1.5) proportionally to the differential pressure. This force is balanced by the range springs (1.4) and results in a deflection of the lever (1.8). The movement of the lever in the high-pressure chamber is transmitted to the pointer mechanism (2.2) located in the indicating unit by a flexible disc (1.9).

The scale is linear for the differential pressure and squared for the flow rate.

Version with limit switches

The gear segment (2.1) carries the tags (3.1) and actuates the alarm contacts by moving the tags into the adjustable proximity switches (3.2).

When the tag enters the pick-up field of the associated proximity switch, the switch becomes highly resistive (contact open). When the tag leaves the field, the proximity switch becomes low resistive (contact closed).

The switching function is activated when the tag moves either into or out of the proximity switch depending on the contact setting.

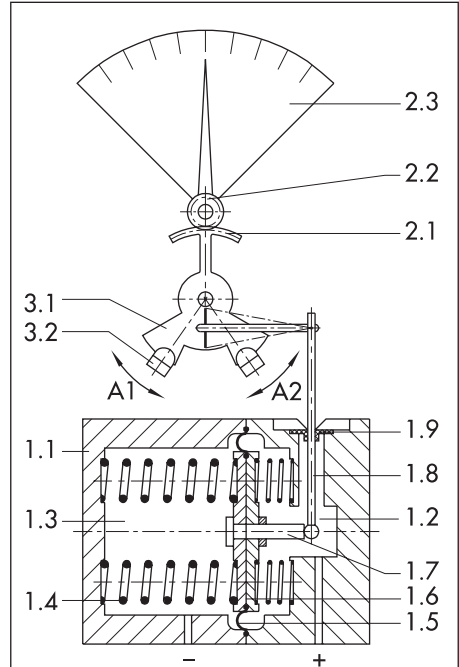

Differential pressure cell	Indicating unit
1.1 dp cell	2.1 Gear segment
1.2 High pressure chamber	2.2 Pointer mechanism
1.3 Low pressure chamber	2.3 Scale
1.4 Range springs	Limit switch (optional)
1.5 Measuring diaphragm	3.1 Metal tags
1.6 Diaphragm plates	3.2 Proximity switches for alarm contacts
1.7 Diaphragm shaft	A1 and A2
1.8 Lever	
1.9 Flexible disk	

Fig. 2 · Version with two alarm contacts

2 Installation

2.1 Arrangement of instruments for liquid level measurement

The center schematic (top row) illustrated on the following page shows the additional height z that is included in the measurement. Therefore, z should be kept as small as possible.

You can select the compensation height K (see schematic on the top right of the following page) as large as required by the installation conditions on site.

2.2 Arrangement of instruments for flow rate measurement

The decision whether you have to attach the instrument above or below the point of measurement or whether you must install equalizing tanks or not depends on the type of process fluid and the conditions on site.

The installation schematics illustrated at the bottom of the following page show standard and reverse installation. Standard installation is always to be preferred. Choose reverse installation only if there is no alternative which often occurs especially when measuring **steam**.

For further details on **reverse installation**, we recommend that you refer to **VDE/VDI 3512 Part 1**.

2.3 Media 05 indicating unit

Make sure that the high-pressure (plus) line is connected to the high-pressure connection and the low-pressure (minus) line to the low-pressure connection of the instrument.

Note: You need screw joints to connect the differential pressure lines. In addition, the unused instrument connections must be fitted with plugs or vent plugs depending on how the instruments are arranged (see also section 3.4).

Carefully clean the connections prior to connecting the differential pressure lines to the instrument. Do not purge the instrument with compressed air or pressurized water.

At the place of installation, attach the instrument to the pipe, wall or mounting plate free of vibrations.

For attachment to vertical or horizontal pipes, use a mounting part with a clamp. For wall mounting, use a mounting part without a clamp.

For panel mounting, a mounting bracket is required (see dimensional drawing in section 7).

Liquid level measurement Shown with SAMSON valve block

- H Measuring range
- h Measured height
- z Additional height
- K Compensation height

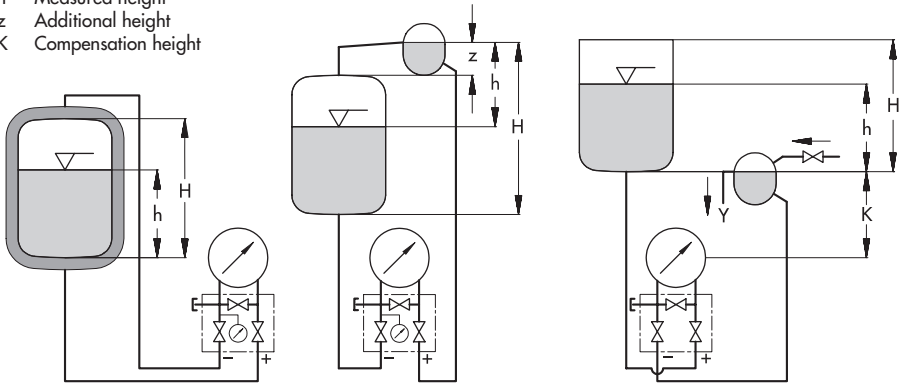

Measurement in cryogenic plants (liquefied gases)

Measurement on pressure vessels with condensing or non-condensing cushion

Measurement on open vessels with low-lying meter

Flow rate measurement

Measuring liquids

Orifice plate assembly

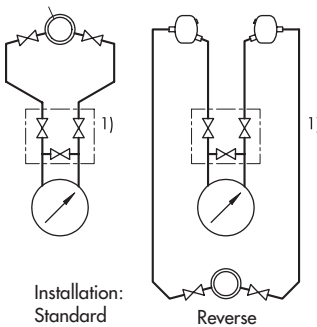

Installation:
Standard

Reverse

Measuring steam

Equalizing tank

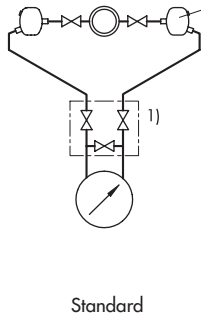

Standard

Measuring gases

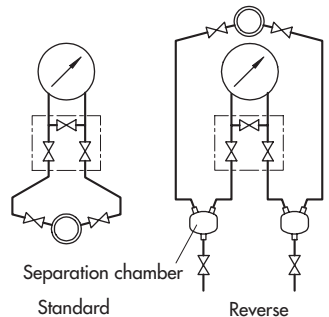

Separation chamber
Standard

Reverse

1) SAMSON valve blocks can be installed upside down with the dp cell on top to match connections (+) to (+) and (-) to (-). Refer to section 3.1 for more details.

Fig. 3 · Arrangement of devices

2.4 Differential pressure lines

Select differential pressure lines with an external diameter of 12 mm and install them according to Fig. 3. Make sure the correct arrangement is chosen.

The use of screw joints ensures tight sealing of the lines.

Lines which would normally be routed horizontally must be installed with a continuous slope of min. 1:20, sloping downward from the orifice plate or the point that enables venting. The smallest bending radius must not be below 50 mm.

Purge the differential pressure lines thoroughly prior to connecting them to the instrument.

2.5 Orifice plate assembly

The process medium flows in the direction indicated by the arrow. An undisturbed, straight length of pipe is required at the inlet and outlet sides of the orifice plate assembly.

With the orifice tubes supplied by SAMSON, these pipe lengths are ensured by the welded-on calibrated pipes. With orifice flanges, the straight length of pipe which must precede the orifice plate is specified in the order confirmation.

The orifice plate assembly and the seals must not be eccentrically displaced to the pipeline.

Do not install control valves, e.g. manually operated valves or temperature regulators, that continuously vary the operating state of the process medium upstream of the orifice plate assembly as the operating state is expected to correspond to the calculated state as much as possible.

Regulators, however, which do not vary the operating state (e.g. pressure regulators) prove to be advantageous upstream of the measuring instrument.

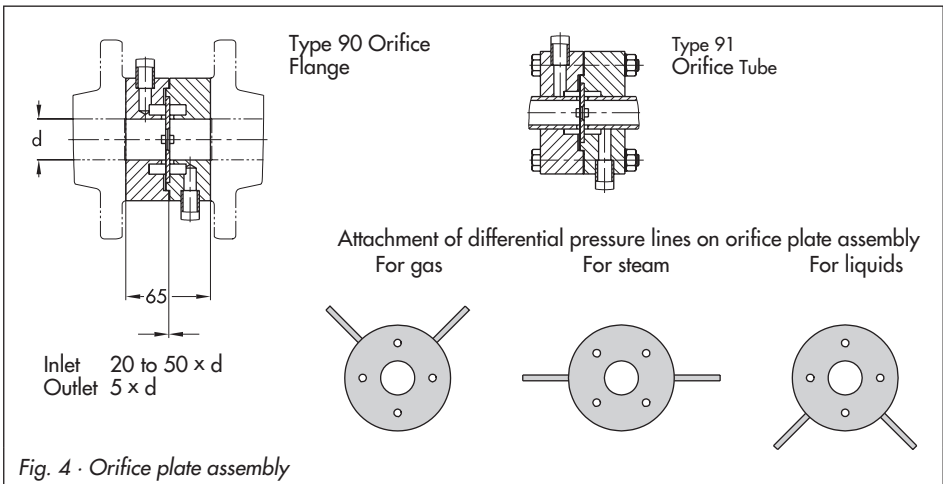

3 Accessories

We recommend that you install both a shut-off valve and, additionally, an equalizing valve in the differential pressure lines. They are used to shut off the two differential pressure lines and to provide a short circuit at the indicating unit for checking zero.

3.1 Valve block

A valve block (Fig. 5) with three combined valves is available (accessories). The valve block is directly flanged to the bottom side of the dp cell.

On measuring the flow rate of liquids and gases, the SAMSON valve block can also be mounted upside down to allow the connections to be assigned properly, i.e. (+) to (+) and (-) to (-). However, the pressure gauge connection can no longer be used due to the reversed mounting and it must be sealed using an O-ring and screw cap G 1/2 - LH (see dimensional diagram in section 7).

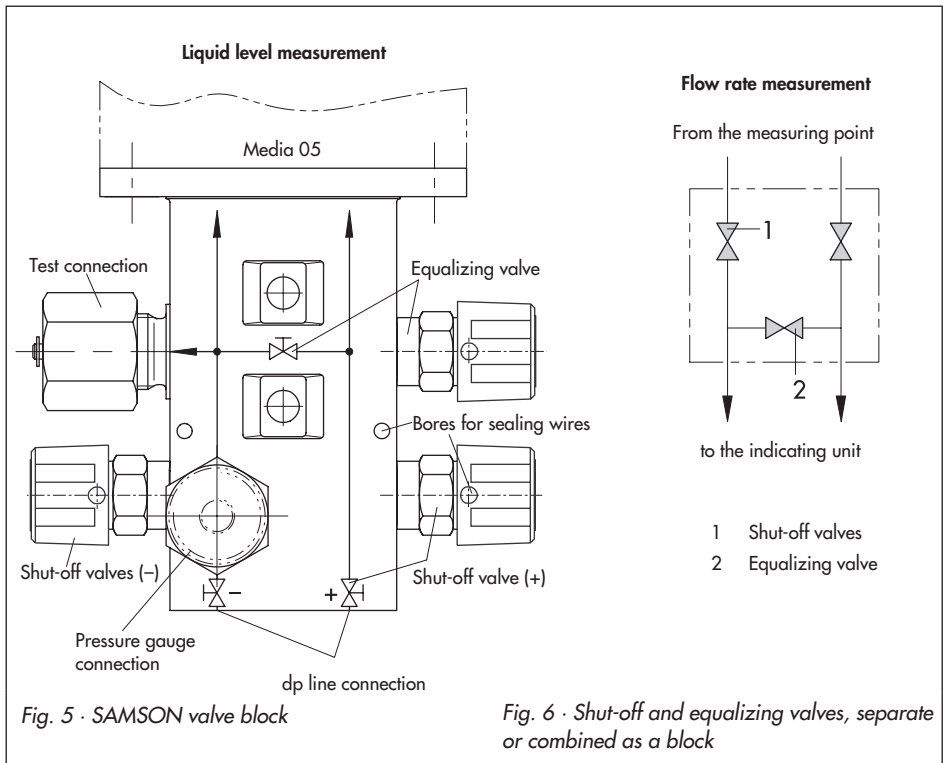

Fig. 5 · SAMSON valve block

Fig. 6 · Shut-off and equalizing valves, separate or combined as a block

3.2 Shut-off and equalizing valves

As an alternative to the SAMSON valve block, you can also install the two shut-off valves as well as the bypass valve/equalizing valve according to Fig. 6.

3.3 Equalizing tanks

Equalizing tanks for maintaining a constant liquid column are required when measuring steam. When measuring liquids, these tanks are only needed if the indicating unit is located above the point of measurement.

When measuring gas, equalizing tanks functioning as **separation chambers** are required for draining the condensate if the indicating unit is located below the point of measurement.

3.4 Accessories for connection

The instruments are supplied without screw joints (versions for oxygen are protected from contamination by four NBR blanking plugs).

Required screw joints, drain or vent plugs as well as screw joints with orifice plates to dampen the vibrations caused by the measured medium (especially gas) must be ordered separately.

Note:

The screw joints as well as SAMSON valve blocks including order numbers are listed in the Data Sheet T 9555 EN.

WARNING!

Oxygen service

*When the device is used for oxygen service, make sure that the dp cell and any SAMSON accessories (e.g. valve block) only come into contact with **gaseous** oxygen.*

4 Start-up

See Fig. 6 for start-up.

4.1 Flow rate measurement

For steam measurement

The steam should never have direct contact with the measuring diaphragm of the instrument. For this reason, unscrew the differential pressure lines located below the shut-off valves or the valve block and fill the instrument with water.

As an alternative method, wait approximately 20 minutes after start-up (steam switched on) with closed shut-off and equalizing valves or closed valve block until condensate in the differential pressure lines rises above the valve up to the orifice plate.

1. Open the high-pressure (plus) line.
2. Close the equalizing valve, i.e. the bypass of the valve block.
3. Open the low-pressure (minus) line.
4. Wait a moment before unscrewing both vent plugs of the dp cell one after the other until condensate escapes free of bubbles. Retighten vent plugs.

In the same manner, vent the equalizing tanks. Lightly tap on the housing of the indicating unit or the equalizing tanks to promote the escape of air.

5. Check zero as described in section 5.1 and put the instrument back into service.

Note:

In case of reverse installation (measuring instrument located above the point of measurement), the differential pressure lines could become partially drained if the plant is relieved of pressure. When starting up again, the measuring arrangement must be vented so that it can refill with condensate.

For liquid measurement

1. Open the high-pressure (plus) line by gradually turning.
2. Close the equalizing valve or the bypass of the valve block.
3. Open the low-pressure (minus) line.

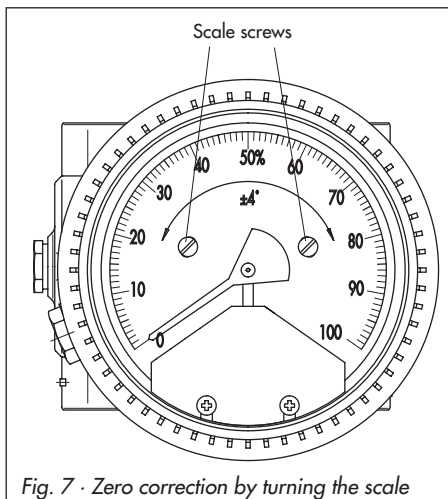

Fig. 7 · Zero correction by turning the scale

4. Unscrew one vent plug of the dp cell until the air has escaped and retighten.
5. Check zero as described in section 5.1 and put the instrument back into service.

4.2 Liquid level measurement

See Fig. 5 for start-up.

Proceed as described in steps 1, 2, 3 and 5 for the flow rate measurement.

Note:

During measurement, make sure that the equalizing valve is closed and that the shut-off valves are open.

NOTICE

For cryogenic applications, an open equalizing valve during measurement causes the medium to circulate and, as a result, the valve block to freeze up.

5 Operation

5.1 Zero adjustment

If the differential pressure lines are fitted with shut-off and equalizing valves, zero can be checked even when the plant is in operation.

1. Close the shut-off valve on the high-pressure side.
2. Open the equalizing valve.
3. Close the shut-off valve on the low-pressure side so that a balance of pressure is achieved in the dp cell.

The pointer must indicate zero.

If it does not read zero, unfasten the scale screws and turn the dial plate (adjustable by $\pm 4^\circ$).

In case of larger deviations, remove the pointer using an appropriate tool. Align the dial plate in the middle position. Then reattach the pointer in zero position on the axis.

For start-up:

1. Open the low-pressure line.
2. Close the equalizing valve.
3. Slowly but gradually open the high-pressure line all the way.

The instrument is in operation again.

For applications with installed valve block, proceed as described above.

5.2 Draining

When gases are measured, the condensate must be drained from the draining tanks from time to time. Close the valves in the differential pressure lines (valve block) prior to opening the drain plugs.

5.3 Adjusting and modifying the measuring range

The measuring range of the differential pressure and flow meter is determined by the installed range springs. The instrument is calibrated at the factory to the range specified in the order. Subsequently, it can only be modified infinitely variably up to approx. 60 % of the max. measuring span (for technical data, refer to page 4).

- ▶ For best results, adjust on the test bench (Fig. 8).

Checking the measuring range:

1. Adjust zero in the depressurized dp cell as described in section 5.1.
2. Make sure that the low-pressure (minus) line is open and apply pressure to the high-pressure (plus) chamber until the pointer indicates 100 %.
Read the pressure gauge and check if the adjusted pressure value corresponds to the current upper range value.
3. Depressurize again.

Correcting and modifying the measuring range:

1. Undo the screws (1) and remove the cover plate (2).
2. Undo the mounting screw (3) so that the unit frame (4) can be moved easily.
3. Place the tip of an appropriate screwdriver into the 7 mm notch for moving the unit frame upward or downward.
If you want to increase the measuring range, turn the screwdriver counterclockwise.
If you want to decrease the measuring range, turn the screwdriver clockwise.
Retighten the mounting screw (3).
4. Correct zero according to section 5.1.
5. Pressurize the dp cell again until the pointer indicates the full-scale value.
6. Check the upper measuring range value, reading the pressure gauge.
Should it not correspond with the desired measuring range, repeat the adjustment procedure until zero and upper range value are properly adjusted.
7. Reattach the cover plate (2) and fasten the screws (1).

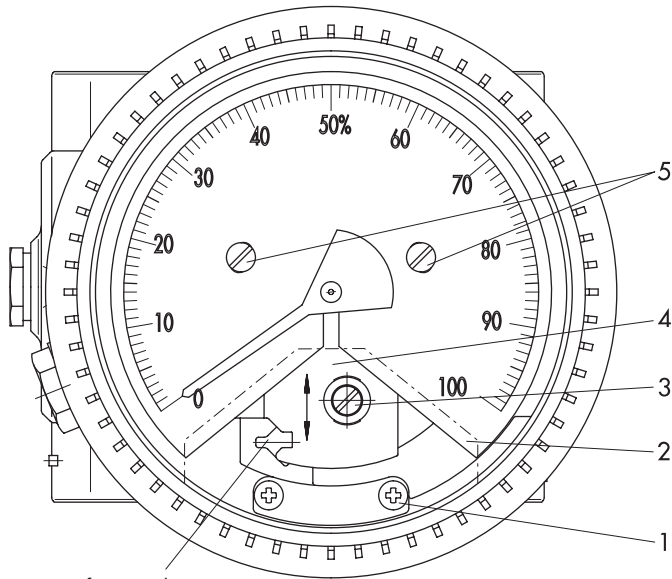

Groove for screwdriver

- 1 Screw
- 2 Cover plate
- 3 Mounting screw
- 4 Unit frame
- 5 Scale screws

WARNING!

For devices in **oxygen service**, make absolutely sure that the test medium is **free of oil and grease**.

Use oil-free air or other gases, e.g. N_2 .

Gaseous oxygen as the process medium

Max. temperature: $+60\text{ }^\circ\text{C}$, max. oxygen pressure: 30 bar

When the device is used for oxygen service, make sure that the dp cell and any SAMSON accessories only come into contact with **gaseous oxygen**.

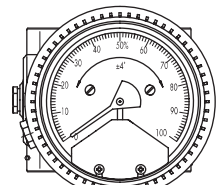

Supply pressure reducing station with oil filter and test pressure gauge

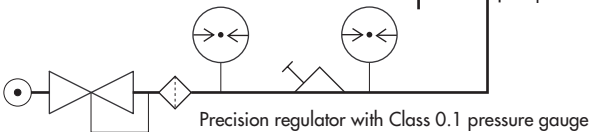

Fig. 8 · Test arrangement and modifying the measuring range

6 Version with limit switches

One or two proximity switches can be installed as alarm contacts (A1 and A2) as follows:

Contact and function	Contact made with	Fig.
Min – A1 as main contact	Bottom	10.2
Min – A1 as main contact	Bottom	10.2
Min – A2 as initial contact	Top	10.2
Min – A1 as main contact	Bottom	10.3
Max – A2 as main contact	Top	10.3

The maximum contact can also be used as a second minimum contact, i.e. as an initial contact. In this case, however, there must be a minimum difference of 15 % between the switching point of the initial contact and that of the main contact A1.

6.1 Electrical connection

This procedure involves connecting the alarm contacts A1 and A2 of the indicating unit to a

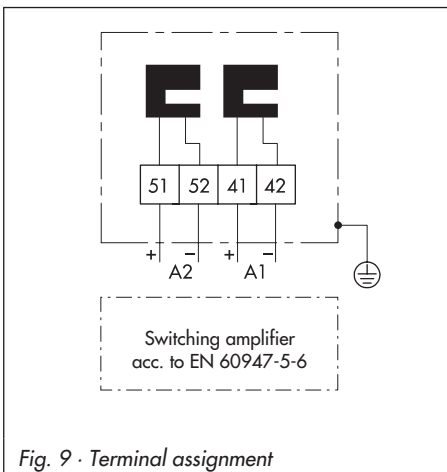

switching amplifier or an alarm system according to Fig. 9.

The listed maximum specifications in the table below apply for the connection of proximity switches to certified intrinsically safe circuits in the type of protection EEx ia IIC T6 (PTB 00 ATEX 2049 X):

	Type 1			Type 2		
U_i	16 V			16 V		
I_i	25 mA			25 mA		
P_i	34 mW			64 mW		
C_i	30 nF			30 nF		
L_i	100 μ H			100 μ H		
T	T6	T5	T4	T6	T5	T4
	73 °C	88 °C	100 °C	66 °C	81 °C	100 °C

6.2 Adjusting the alarm contacts

The minimum contacts A1 and A2 as well as the contacts in the combination with minimum contact A1 and maximum contact A2 can be shifted in the range of 0 to 100 % of the adjusted measuring span. Minimum and maximum contacts have different designs.

Contact is made when the tag moves approximately 6 mm into the proximity switch.

Minimum contacts:

Always adjust the switching points according to the decreasing characteristic. The bottom edge of the tag causes the contact to be made.

Maximum contacts:

Always adjust the switching points according to the increasing characteristic. The top edge of the contact causes the contact to be made.

Adjustment with pressure specifications

- ▶ Connect the device to a switching amplifier as described in section 6.1.
- ▶ Apply a pressure to the high-pressure connection of the dp cell which corresponds to the desired switching point.
NOTICE The low-pressure connection of the dp cell must be open for this purpose.

Loosen the clamping screw of the proximity switch bracket according to Fig. 10 and manually move the contact into the desired switching position (note that the middle of the bracket indicates the position).

Minimum contact:

From the left, move the proximity switch onto the left side of the tag until contact is made.

Maximum contact:

From the right, move the proximity switch onto the right side of the tag until contact is made.

- ▶ Slightly tighten the clamping screw.
- ▶ Check the switching point and repeat adjustment, if necessary.

Adjustment without pressure specifications

e.g. on site

- ▶ Connect the instrument to a switching amplifier as described in section 6.1.

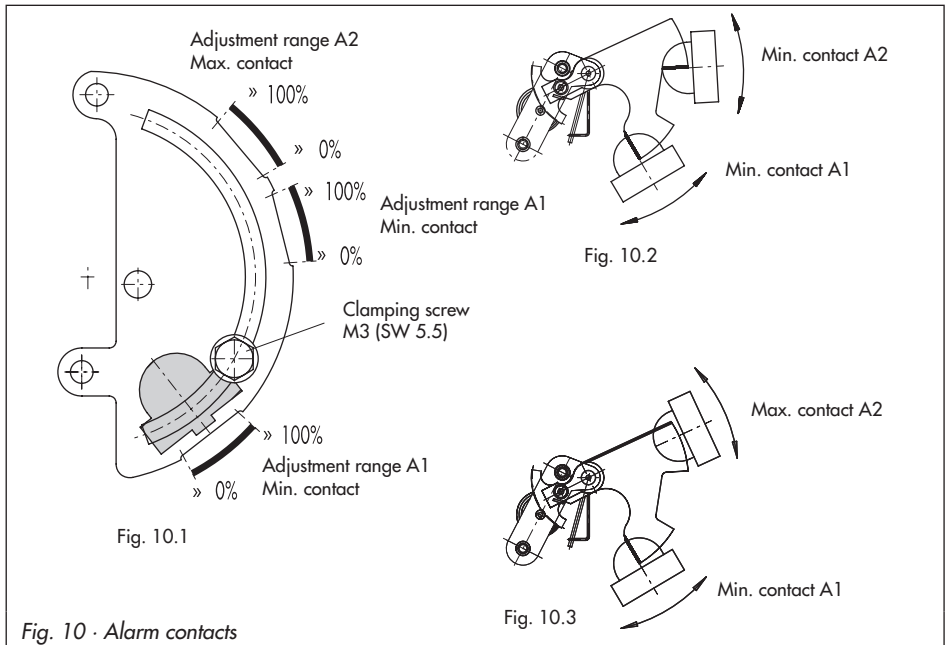

Fig. 10 · Alarm contacts

Adjust the tag by carefully moving the pointer manually.

NOTICE

Do not move the pointer past the currently indicated position on the dial. You may move the pointer below the indicated position.

When the tank is full with 100 % reading, the above action can always be performed, however, when the tank is empty and the dial indicates 0 %, this is not possible.

6.3 Retrofitting/replacing the contact unit

The contacts can only be retrofitted or replaced as complete units.

Contact module
Order no.

1 Min. contact	A1	1400-7570
2 Min. contacts	A1 and A2	1400-7571
1 Min. contact	A1 and	1400-7720
1 Max. contact	A2	

1. Unscrew the case cover.
2. Undo the screws (1, Fig. 8) and remove the cover plate (2, Fig. 8).
3. Undo the two scale screws (5, Fig. 8), lift the dial forward toward the pointer and then remove it upward.
4. Slide the contact unit (2) onto the unit frame plate from the right so that the metal tags reach into the proximity switches without touching the contacts.
5. Secure the contact unit (2) to the unit frame using two slotted head screws (5).
6. Establish the connecting line (4.1) for the alarm contact A1 below the unit frame and the connecting line (4.2) for the alarm contact A2 above the unit frame. Ensure that the lines do not prevent the tags from moving into and out of the proximity switches. Moreover, make sure that the lines are not damaged when tightening the case cover later on.

7. Insert the printed circuit board (1) into the positioning notch from the left and tighten it using a Philips screw (6).
8. Replace the blanking plug of the indicating unit with a cable gland (8) M12x1.5.
Protect the cable gland against water entering until the signal line has been established.
9. Establish the electrical connection as described in section 6.1.
10. Reposition the dial from the top and secure it to the unit frame using the scale screws (2, Fig. 8) assuring the right zero position according to section 5.1.
11. Attach the case cover and screw tight preventing the connecting lines of the proximity switches from being damaged.

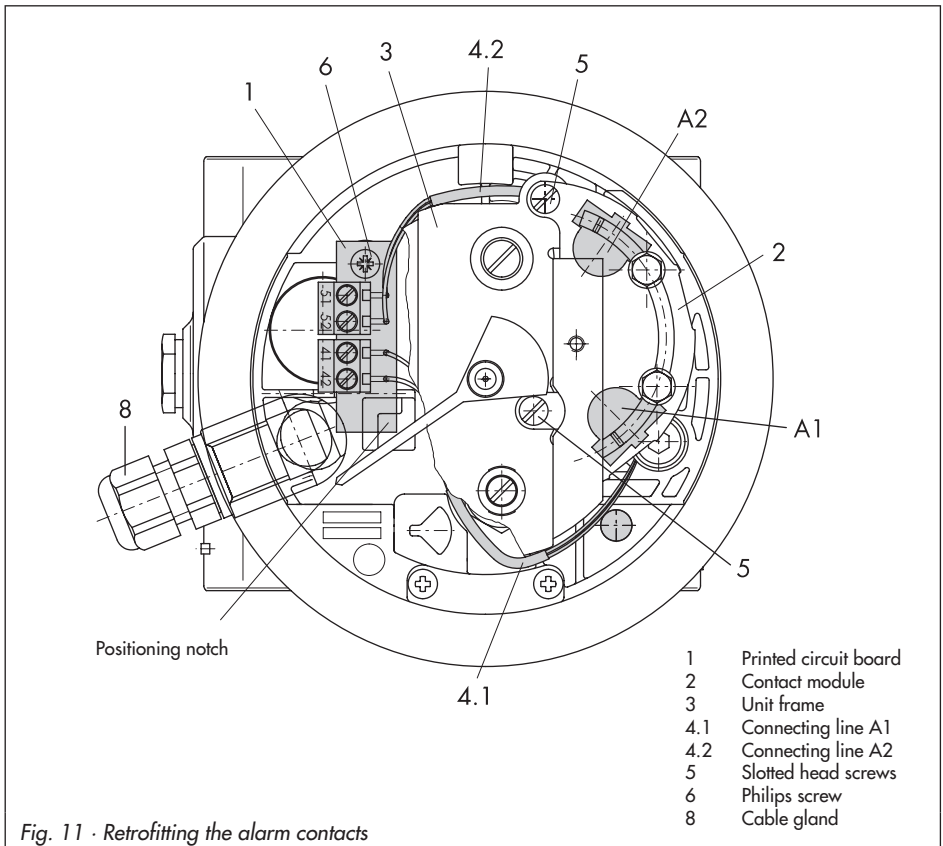
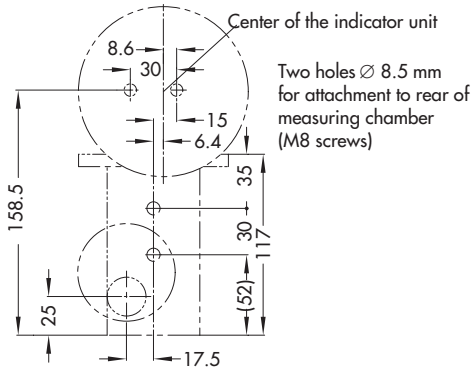

Fig. 11 · Retrofitting the alarm contacts

7 Dimensions in mm

Hole pattern for wall/panel mounting



Two holes \varnothing 8.5 mm for attachment to valve block (M8 screws)

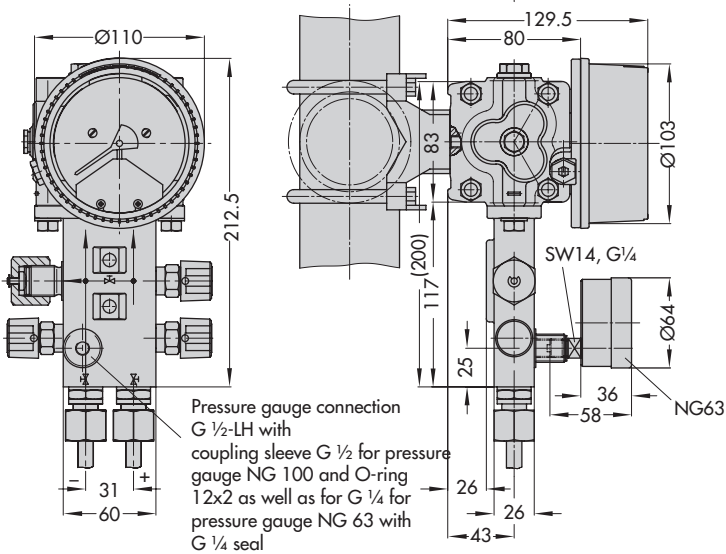
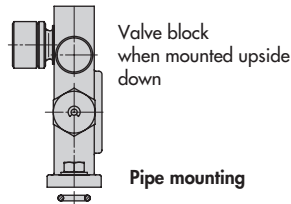

Fig.12 · Dimensional drawing



SAMSON AG · MESS- UND REGELTECHNIK
Weismüllerstraße 3 · 60314 Frankfurt · Germany
Phone: +49 69 4009-0 · Fax: +49 69 4009-1507
Internet: <http://www.samson.de>

EB 9520 EN

S/Z 2011-03