

Flange connecting dimensions for PN 6, PN 10, PN 16, PN 25, and PN 40

Fig. 1 shows the schematic arrangement of the bolt holes, not their exact number.

For the exact number of bores, refer to Table 1, column "No. n".

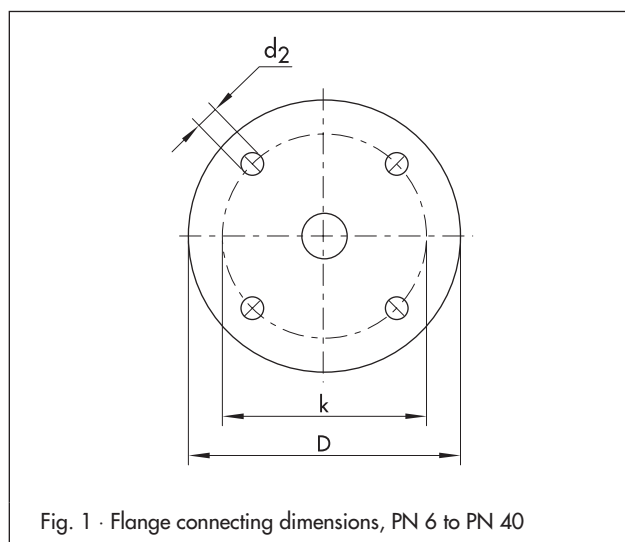

Fig. 1 · Flange connecting dimensions, PN 6 to PN 40

¹⁾ Flange connecting dimensions for PN 160, PN 250, and PN 320 correspond to the specifications in DIN 2501-1

Table 1 · Connecting dimensions for PN 6, PN 10, PN 16, PN 25, and PN 40

Dimensions in mm

Nominal size	PN 6				PN 10				PN 16				PN 25				PN 40			
	Outside ∅	Bolt circle ∅	Bolt holes No.	Bolt holes ∅	Outside ∅	Bolt circle ∅	Bolt holes No.	Bolt holes ∅	Outside ∅	Bolt circle ∅	Bolt holes No.	Bolt holes ∅	Outside ∅	Bolt circle ∅	Bolt holes No.	Bolt holes ∅	Outside ∅	Bolt circle ∅	Bolt holes No.	Bolt holes ∅
	D	k	n	d ₂	D	k	n	d ₂	D	k	n	d ₂	D	k	n	d ₂	D	k	n	d ₂
15	80	55	4	11	95	65	4	14	95	65	4	14	95	65	4	14	95	65	4	14
20	90	65	4	11	105	75	4	14	105	75	4	14	105	75	4	14	105	75	4	14
25	100	75	4	11	115	85	4	14	115	85	4	14	115	85	4	14	115	85	4	14
32	120	90	4	14	140	100	4	18	140	100	4	18	140	100	4	18	140	100	4	18
40	130	100	4	14	150	110	4	18	150	110	4	18	150	110	4	18	150	110	4	18
50	140	110	4	14	165	125	4	18	165	125	4	18	165	125	4	18	165	125	4	18
65	160	130	4	14	185	145	8	18	185	145	8 ¹⁾	18	185	145	8	18	185	145	8	18
80	190	150	4	18	200	160	8	18	200	160	8	18	200	160	8	18	200	160	8	18
100	210	170	4	18	220	180	8	18	220	180	8	18	235	190	8	22	235	190	8	22
125	240	200	8	18	250	210	8	18	250	210	8	18	270	220	8	26	270	220	8	26
150	265	225	8	18	285	240	8	22	285	240	8	22	300	250	8	26	300	250	8	26
200	320	280	8	18	340	295	8	22	340	295	12	22	360	310	12	26	375	320	12	30
250	375	335	12	18	395	350	12	22	405	355	12	26	425	370	12	30	450	385	12	33
300	440	395	12	22	445	400	12	22	460	410	12	26	485	430	16	30	515	450	16	33
350	490	445	12	22	505	460	16	22	520	470	16	26	555	490	16	33	580	510	16	36
400	540	495	16	22	565	515	16	26	580	525	16	30	620	550	16	36	660	585	16	39

¹⁾ According to EN 1092-2 (cast iron flanges) and EN 1092-3 (copper alloy flanges), flanges in this PN and DN may be delivered with 4 bolt holes. If steel flanges with 4 holes are required, they may be delivered after prior consultation between manufacturer and customer.

Flange connecting dimensions for PN 63, PN 100, PN 160, PN 250, and PN 320

Flange connecting dimensions for **PN 160, PN 250, and PN 320** correspond to the specifications in **DIN 2501-1**.

Fig. 2 shows the schematic arrangement of the bolt holes, not their exact number.

For the exact number of bores, refer to Table 2, column "No. n".

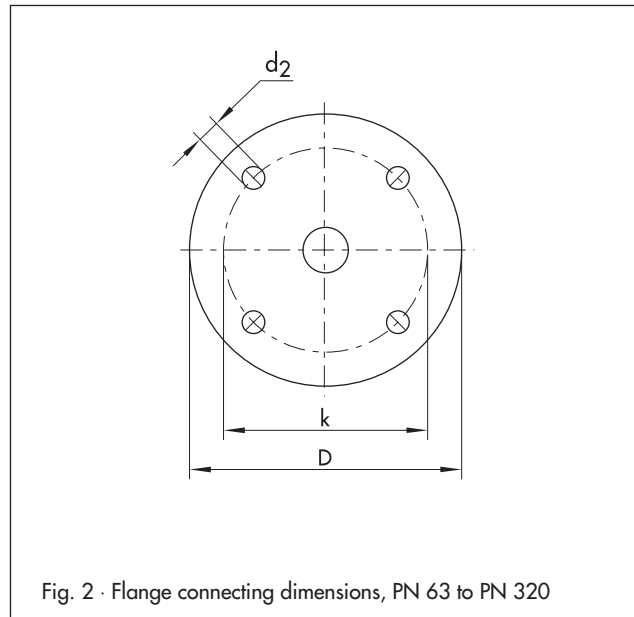

Fig. 2 · Flange connecting dimensions, PN 63 to PN 320

Table 2 · Connecting dimensions, PN 63, PN 100, PN 160, PN 250, and PN 320

Dimensions in mm

Nominal size	PN 63				PN 100				PN 160				PN 250				PN 320			
	Outside	Bolt	Bolt holes		Outside	Bolt	Bolt holes		Outside	Bolt	Bolt holes		Outside	Bolt	Bolt holes		Outside	Bolt	Bolt holes	
	∅	circle ∅	No.	∅	∅	circle ∅	No.	∅	∅	circle ∅	No.	∅	∅	circle ∅	No.	∅	∅	circle ∅	No.	∅
	D	k	n	d ₂	D	k	n	d ₂	D	k	n	d ₂	D	k	n	d ₂	D	k	n	d ₂
15	105	75	4	14	105	75	4	14	105	75	4	14	130	90	4	18	130	90	4	18
20	130	90	4	18	–	–	–	–	–	–	–	–	–	–	–	–	–	–	–	–
25	140	100	4	18	140	100	4	18	140	100	4	18	150	105	4	22	160	115	4	22
32	155	110	4	22	155	110	4	22	–	–	–	–	–	–	–	–	–	–	–	–
40	170	125	4	22	170	125	4	22	170	125	4	22	185	135	4	26	195	145	4	26
50	180	135	4	22	195	145	4	26	195	145	4	26	200	150	8	26	210	160	8	26
65	205	160	8	22	220	170	8	26	220	170	8	26	230	180	8	26	255	200	8	30
80	215	170	8	22	230	180	8	26	230	180	8	26	255	200	8	30	275	220	8	30
100	250	200	8	26	265	210	8	30	265	210	8	30	300	235	8	33	335	265	8	36
125	295	240	8	30	315	250	8	33	315	250	8	33	340	275	12	33	380	310	12	36
150	345	280	8	33	355	290	12	33	355	290	12	33	390	320	12	36	425	350	12	39
200	415	345	12	36	430	360	12	36	430	360	12	36	485	400	12	42	525	440	16	42
250	470	400	12	36	505	430	12	39	515	430	12	42	585	490	16	48	640	540	16	52
300	530	460	16	36	585	500	16	42	585	500	16	42	690	590	16	52	–	–	–	–
350	600	525	16	39	655	560	16	48	–	–	–	–	–	–	–	–	–	–	–	–
400	670	585	16	42	715	620	16	48	–	–	–	–	–	–	–	–	–	–	–	–

