

Self-operated Temperature Regulators

Type 1 to Type 9

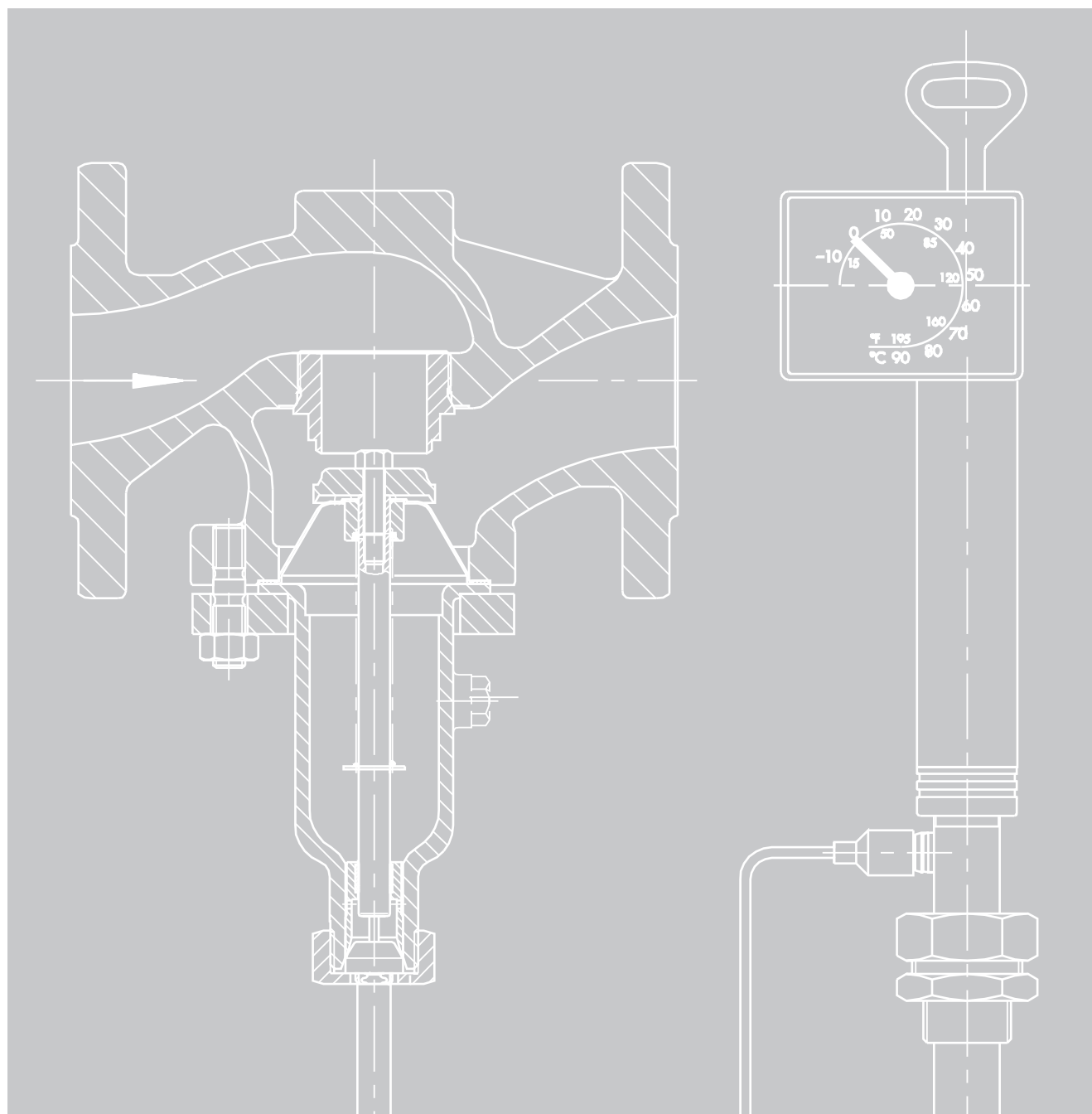

PN 16 to 40 · Class 125 to 300
DN 15 to 250 · NPS ½ to 10
G ½ to 1 · Up to 350 °C · Up to 660 °F

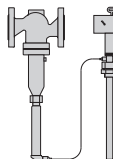
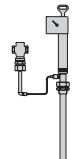
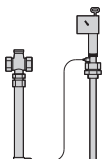
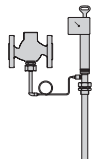

Self-operated temperature regulators

Valves	Applications with	Steam	•	•		
		Water and other liquids	•	•	•	•
		Air and non-flammable gases	•	•		
		Heating	•	•		
		Cooling			•	•
		Mixing/diverting				
	Globe valve		•	•	•	•
	Three-way valve					
	Pressure-balanced					• 4)
	Not balanced		•	•	•	•
	Connection	Flanges	•			•
		Female thread		•	•	•
	Nominal size		DN 15 to 50	G ½ to G 1	G ½ to G 1	DN 15 to 50
	Nominal pressure		PN 16 to 40	PN 25	PN 25	PN 16 to 40
Perm. temperature max.		350 °C ¹⁾	220 °C	150 °C	150 °C	
Body material	Cast iron (EN-JL1040/A126B)		• ²⁾			
	Spher. graphite iron (EN-JS1049)		•		•	
	Cast steel (1.0619/A216 WCC)		•			
	Stainl. steel (1.4408/A351 CF8M)		•			
	Red brass (CC491K/CC499K)			•	•	
Control thermostats	Type 2231 and Type 2232		•	•	•	•
	Type 2233 and Type 2234		•	•	•	•
	Type 2235		•	•	•	•
	Adjustable set point		-10 to +250 °C			
	Optionally available with double adapter		•	•	•	•
Safety thermostats	Type 2212 for safety temperature limiter - STL -		•	•	•	•
	Adjustment range of limit value		10 to 95 °C · 20 to 120 °C · 30 to 170 °C			
	Type 2213 for safety temperature monitor - STM -		•	•	•	•
Adjustment range of limit value		-10 to 90 °C · 20 to 120 °C				
Type ...		1	1	1u	1u	
For details, refer to Data Sheet ...		T 2111 EN	T 2112 EN ³⁾	T 2113 EN	T 2113 EN	
						

¹⁾ Only with extension piece ²⁾ DN 15 only 25: EN-JS1049 only ³⁾ ANSI version on request ⁴⁾ Pressure balancing in DN 32 to 50

Control thermostats

Type 2231 · Set point adjustment at the sensor · Set points from -10 to +150 °C (15 to 300 °F) · Suitable for liquids and steam · Suitable for installation in pipelines, tanks and other heating and cooling installations

Type 2232 · Separate set point adjustment · Set points from -10 to +250 °C (15 to 480 °F) · Application same as Type 2231

Type 2233 · Set point adjustment at the sensor · Set points from -10 to +150 °C (15 to 300 °F) · Suitable for liquids, air and gases · Suitable for installation in air ducts, tanks, pipelines and other heating and cooling installations · Regulation of liquids with short response times

Type 2234 · Separate set point adjustment · Set points from -10 to +250 °C (15 to 480 °F) · Application same as Type 2233

Type 2235 · Separate set point adjustment · Set points from -10 to +250 °C (15 to 480 °F) · Sensor tube to be installed on site for measuring different temperature layers · Suitable for installation in air-heated storage rooms, drying, climatic and heating cabinets · Suitable for air and gases

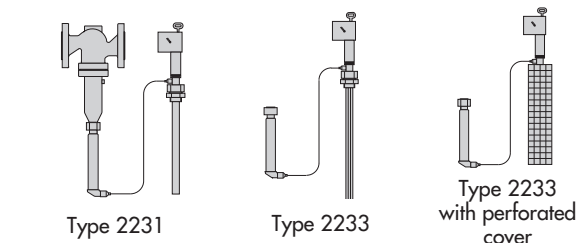

Fig. 1 · Control thermostats with set point adjustment at the sensor

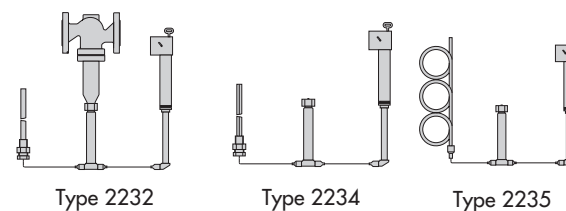
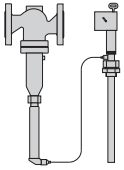
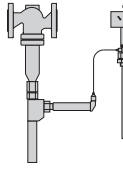
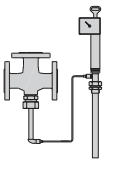
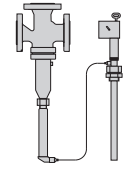
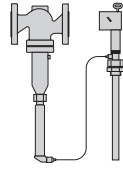
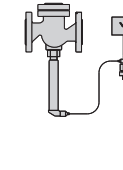

Fig. 2 · Control thermostats with separate set point adjustment

•				•	
•	•	•	•	•	•
•	•	•		•	
•				•	
	•				•
		•	•		
•	•			•	•
		•			
•	•		• ¹⁾		
		•		•	•
•	•	•	•	•	•
DN 15 to 250	DN 15 to 250	DN 15 to 50	DN 15 to 150	NPS ½ to 4	NPS ½ to 2
PN 16 to 40	PN 16 to 40	PN 16	PN 16 to 40	Class 125 to 300	Class 125 to 300
350 °C	220 °C	150 °C	350 °C ¹⁾	660 °F	300 °F
•	•	•	•		•
•	•		•		
•	•		•		•
•	•		•		•
•	•	•	•	•	•
•	•	•	•	•	•
•		•	•	•	
-10 to +250 °C				15 to +480 °F	
•		•	•	•	
•		•	•	•	
10 to 95 °C · 20 to 120 °C · 30 to 170 °C				50 to 205 °F · 70 to 250 °F · 85 to 340 °F	
•		•	•	•	
-10 to 90 °C · 20 to 120 °C				15 to 195 °F · 70 to 250 °F	
4	4u	8	9	1	1u
T 2121 EN	T 2123 EN²⁾	T 2131 EN	T 2133 EN²⁾	T 2115 EN	T 2114 EN
					

¹⁾ DN 15 to 25: not balanced · ²⁾ ANSI version on request

Typetested safety thermostats

For the control, limitation, safety monitoring and safety limitation of energy supplied to heating generating systems and heat exchangers which must be equipped with typetested devices, the following typetested equipment is available:

- Temperature regulator (TR)
- Safety temperature monitors (STM)
- Safety temperature limiters (STB) and
- Combination with these devices

Refer to Information Sheet T 2040 EN as well as Data Sheets T 2043 EN and T 2046 EN for more details.

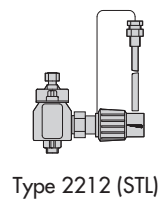

Type 2212 (STL)

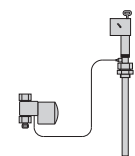

Type 2213 (STM)

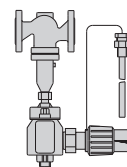

Type 1/2212
Type 4/2212

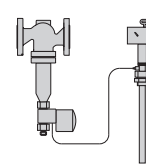

Type 1/2213 or
Type 4/2213

Fig. 3 · Safety thermostats

Self-operated temperature regulators - ANSI versions

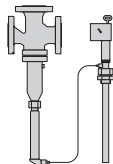
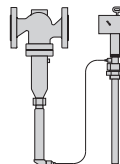
Valves	Applications with	Steam	•	•
		Water and other liquids	•	•
		Air and non-flammable gases	•	•
		Heating		•
		Cooling		
		Mixing/diverting	•	
	Globe valve			•
	Three-way valve		•	
	Pressure-balanced		•	•
	Not balanced			
	Connection	Flanges	•	
		Female thread		•
	Nominal size		NPS ½ to 6	NPS ½ to 10
	Nominal pressure		Class 150 and 300	Class 125 to 300
Perm. temperature	max.	660 °F	660 °F	
Body material	Cast iron (EN-JL1040/A126B)		•	
	Spheroidal graphite iron (EN-JS1049)			
	Cast steel (1.0619/A216 WCC)	•	•	
	Stainless steel (1.4408/A351 CF8M)	•	•	
	Red brass (CC491K/CC499K)			
Control thermostats	Type 2231 and Type 2232	•	•	
	Type 2233 and Type 2234	•	•	
	Type 2235	•	•	
	Adjustable set point	15 to 480 °F		
	Optionally available with double adapter	•	•	
Safety thermostats	Type 2212 for safety temperature limiter	•	•	
	- STL - Adjustment range of limit value	105 to 205 °F · 160 to 250 °F · 210 to 340 °F		
	Type 2213 for safety temperature monitor	•	•	
	- STM - Adjustment range of limit value	15 to 195 °F · 70 to 250 °F		
Type ...		9	4	
For details, refer to Data Sheet ...		T 2134 EN	T 2025 EN	
				

Dynamic behavior of thermostats

The regulator's dynamics basically depends on the response behavior and the characteristic time constant of the sensor used. Table 1 shows the time response of SAMSON control thermostats suitable for Type 1 to Type 9 Temperature Regulators working according to various operating principles measured with water.

Table 1 · Time response of SAMSON thermostats

Operating principle	Type ... Control Thermostat	Time constant in s	
		Without thermowell	With thermowell
Liquid expansion	2231	70	120
	2232	65	110
	2233	25	– ¹⁾
	2234	15	– ¹⁾
	2235	10	– ¹⁾
	2213	70	120
Adsorption	2212	– ¹⁾	40

¹⁾ Not permissible

Pressure-temperature diagrams

The pressure values specified in the individual data sheets are maximum values that are further limited by the values of the associated pressure-temperature diagrams.

The pressure-temperature diagrams for DIN materials were drawn up on the basis of DIN EN 12516-1 and the diagrams for ANSI materials were drawn up on the basis of ASME B16.1 and ASME B16.34.

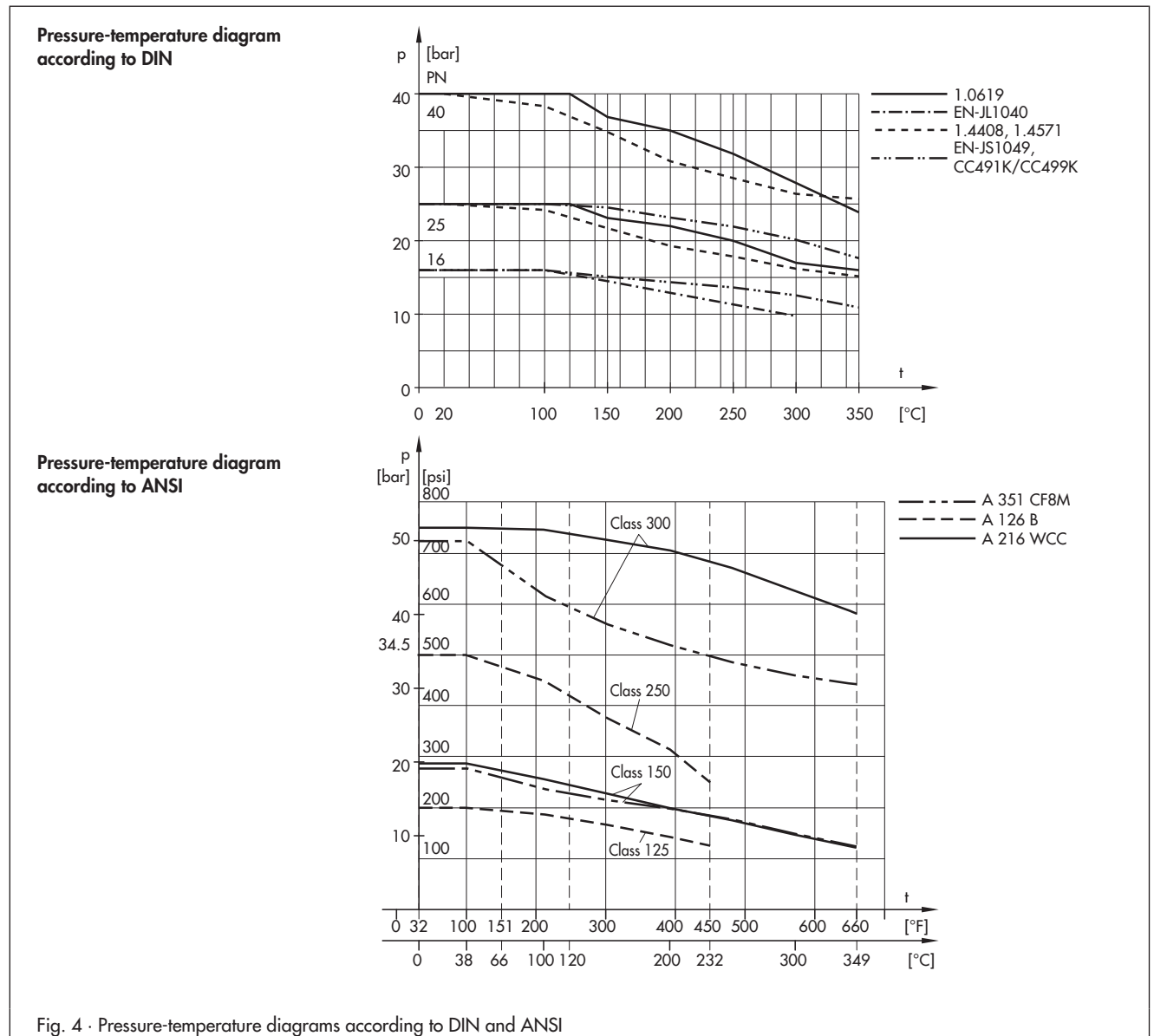

Fig. 4 · Pressure-temperature diagrams according to DIN and ANSI

Conversion factors

K_{VS} and C_V coefficients

The valve flow coefficients can be determined accurately using IEC 60534, Part 2-1 and Part 2-2. In addition, the equations specified in the ISA-S75.01-1-1985 standard and the VDI/VDE Guideline 2173 can be used for this purpose. Calculating the K_V coefficient according to the methods provided by the VDI/VDE guideline is sufficiently accurate in most cases.

The equations can be found in SAMSON's AB 04 EN Calculation Sheet.

$$K_{VS} = 0.86 \times C_V \quad K_{VS} \quad [\text{m}^3/\text{h}]$$

$$C_V = 1.17 \times K_{VS} \quad C_V \quad [\text{U.S. gallons}/\text{min}]$$

Pressure

$$1 \text{ pound}/\text{square inch} [\text{lbs}/\text{in}^2 = \text{psi}] = 0.06895 \text{ bar}$$

$$1 \text{ bar} = 14.5 \text{ psi}$$

Area

$$1 \text{ square inch} [\text{sq.in}; \text{in}^2] = 6.452 \text{ cm}^2 \cdot 1 \text{ cm}^2 = 0.155 \text{ in}^2$$

Mass

$$1 \text{ pound} [\text{lb}] = 0.4536 \text{ kg} \cdot 1 \text{ kg} = 2.2046 \text{ lb}$$

Mass flow

$$1 \text{ pound per second} [\text{lb}/\text{s}] = 0.4536 \text{ kg}/\text{s} \cdot 1 \text{ kg}/\text{s} = 2.2046 \text{ lb}/\text{s}$$

Flow rate

$$1 \text{ U.S. gallon per min} [\text{US gal}/\text{min}] = 0.227 \text{ m}^3/\text{h}$$

$$1 \text{ m}^3/\text{h} = 4.4 \text{ US gal}/\text{min}$$

Temperature

$$^\circ\text{F} = \frac{9}{5} ^\circ\text{C} + 32 \cdot ^\circ\text{C} = \frac{5}{9} (^\circ\text{F} - 32)$$

Principle of operation

Self-operated temperature regulators are control devices which extract the energy required to position the valve from the temperature of the process medium.

The temperature regulators shown in Figs. 5.1, 5.2 and 5.3 operate according to the liquid expansion principle.

They consist of a valve and a control thermostat.

The control thermostat comprises a temperature sensor (11), set point adjuster (13), capillary tube (10) and a hydraulic actuator termed the operating element (7). The sensor is filled with an expansion liquid which acts via the positioning bellows (9) and the positioning pin (8) upon the valve plug (3) attached to the plug stem (6). The temperature-dependent change in volume of the liquid contained in the sensor and the displacement of the piston (12) located in the set point adjuster cause the bellows and the plug to move.

The hydraulic actuator and the valve which does not contain a packing ensure high operating reliability of the regulators. Since the regulators operate on the liquid expansion principle, the temperature sensor and the control thermostat can be adapted to different operating conditions.

Therefore, the easy-to-install versions shown in Figs. 5.1 and 5.2 are used in most cases. The version illustrated in Fig. 5.3 is used for temperatures exceeding 150 °C (300 °F) and in applications where separate installation of the sensor and the set point adjuster is appropriate. The selection of a Type 2231, 2232, 2333, 2234 or 2235 Temperature Sensor depends on the medium, required time constant and installation situation.

The regulators are proportional devices operated by the process medium.

Each time the temperature measured deviates from the adjusted set point, the valve plug position changes. The accuracy and stability of the control process depend on the disturbances occurring in the controlled systems, such as changes in the upstream pressure and flow rate. The regulators are designed to keep the effect of these disturbances small: they can be equipped with a balancing bellows or a balancing plug to eliminate the disturbing forces that are produced by the differential pressure across the valve and act on the valve plug. In unbalanced versions (Fig. 5.1), the disturbing forces result from the cross-sectional seat area and the differential pressure across the seat orifice. The valves shown in Figs. 5.2 and 5.3 are equipped with a balancing bellows.

The pressure upstream of the valve plug (p_1) acts through a bore in the plug stem on the outer bellows surface, whereas the pressure downstream of the valve plug (p_2) acts on the inner surface of the bellows. In this way, the forces acting on the valve plug are balanced. By using these fully balanced valves, self-operated regulators can be designed in nominal sizes up to DN 250 (valves up to NPS 10 on request).

Legends for Figs. 5.1 to 5.3

Valve

1	Valve body	5	Balancing bellows
2	Seat	6	Plug stem
3	Plug	6.1	Plug stem with hole for pressure balancing
4	Bellows housing		

Control thermostat

7	Operating element	11	Temperature sensor
8	Positioning pin	12	Piston
9	Positioning bellows	13	Set point adjustment
10	Capillary tube	14	Set point dial

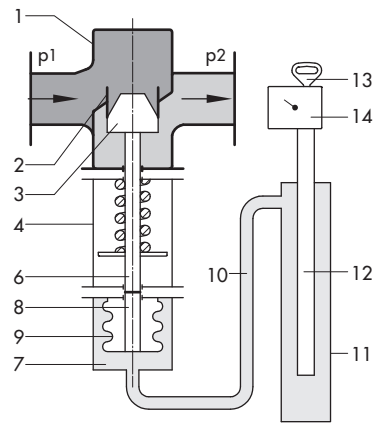

Fig. 5.1 · Temperature regulator with unbalanced valve and compact thermostat

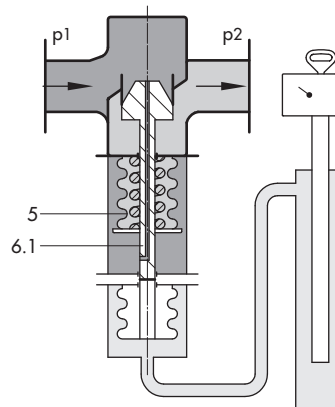

Fig. 5.2 · Temperature regulator with balanced valve and compact thermostat

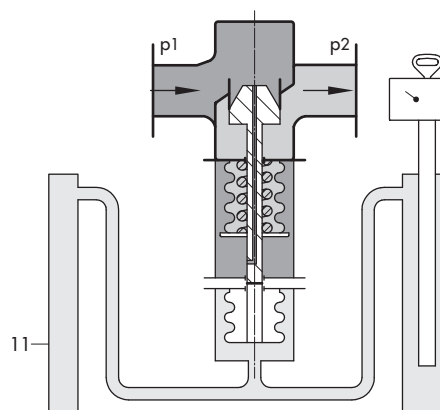

Fig. 5.3 · Temperature regulator with balanced valve and a thermostat with separate set point adjustment

Fig. 5 · Schematic diagrams of Type 1 to Type 9 Temperature Regulators

Type 1 to Type 9 Temperature Regulators

The temperature regulators consist of a valve (globe or three-way valve) and a Type 2231, 2232, 2233, 2234 or 2235 Control Thermostat including temperature sensor, set point adjuster, capillary tube and operating element

Special features

- Low-maintenance P-regulators requiring no auxiliary energy
- Globe or three-way valve for liquids, gases and vapors, especially for the heat transfer media of water, oil and steam or for coolants, for example cooling water or brine
- Valve body material optionally available as cast iron, spheroidal graphite iron (DIN version only), cast steel, cast stainless steel or red brass
- DIN and ANSI versions available

Regulators with globe valves

- Regulators for heating installations

Type 1 Temperature Regulator · Flange connections

With unbalanced Type 2111 Single-seated Globe Valve · Body made of either cast iron, spheroidal graphite iron, cast steel or cast stainless steel · The valve closes as the temperature rises · Type 2231 to Type 2235 Control Thermostats

Technical data	Data Sheets T 2111 EN · T 2115 EN
Set points	-10 to +250 °C · 15 to 480 °F
Nominal size	DN 15 to 50 · NPS ½ to 2
Nominal pressure	PN 16 to 40 · Class 125 to 300
Temperatures	Up to 350 °C ¹⁾ · Up to 660 °F

¹⁾ EN-JL1040/A126B: max. perm. temperature 300 °C

Type 1 Temperature Regulator · Screwed ends

With unbalanced Type 2111 Single-seated Globe Valve · Red brass body · The valve closes as the temperature rises · Type 2231 to Type 2235 Control Thermostats

Technical data	Data Sheet T 2112 EN
Set points	-10 to +250 °C
Nominal size	G ½ to 1
Nominal pressure	PN 25
Temperatures	
Gases	Up to 80 °C
Liquids, vapors	Up to 220 °C

Type 4 Temperature Regulator · Flange connections

With balanced Type 2114 Single-seated Globe Valve · Body made of either cast iron, spheroidal graphite iron (DIN version only), cast steel or cast stainless steel · The valve closes as the temperature rises · Type 2231 to Type 2235 Control Thermostats

Technical data	Data Sheet T 2121 EN/T 2650 EN · T 2025 EN
Set points	-10 to +250 °C · 15 to 480 °F
Nominal size	DN 15 to 250 · NPS ½ to 10
Nominal pressure	PN 16 to 40 · Class 125 to 300
Temperatures	Up to 350 °C · Up to 660 °F

Regulators with three-way valves for temperatures of max. 350 °C when used in mixing or flow diverting services

- Regulators for heating or cooling installations

Type 8 Temperature Regulator · Flange connections

With unbalanced Type 2118 Three-way Valve · Cast iron body · For mixing or diverting liquids · Type 2231 to Type 2235 Control Thermostats

Technical data	Data Sheet T 2131 EN
Set points	-10 to +250 °C
Nominal size	DN 15 to 50
Nominal pressure	PN 16
Temperature	Up to 150 °C

Type 9 Temperature Regulator · Flange connections

With balanced Type 2119 Three-way Valve ¹⁾ · Body made of either cast iron, cast steel or cast stainless steel · For mixing or diverting liquids · Type 2231 to Type 2235 Control Thermostats

Technical data	Data Sheet T 2133 EN · T 2134 EN
Set points	-10 to +250 °C · 15 to 480 °F
Nominal size	DN 15 to 150 · NPS ½ to 6
Nominal pressure	PN 16 to 40 · Class 150 and 300
Temperatures	Up to 350 °C · Up to 660 °F

¹⁾ DN 15 to 25: not balanced

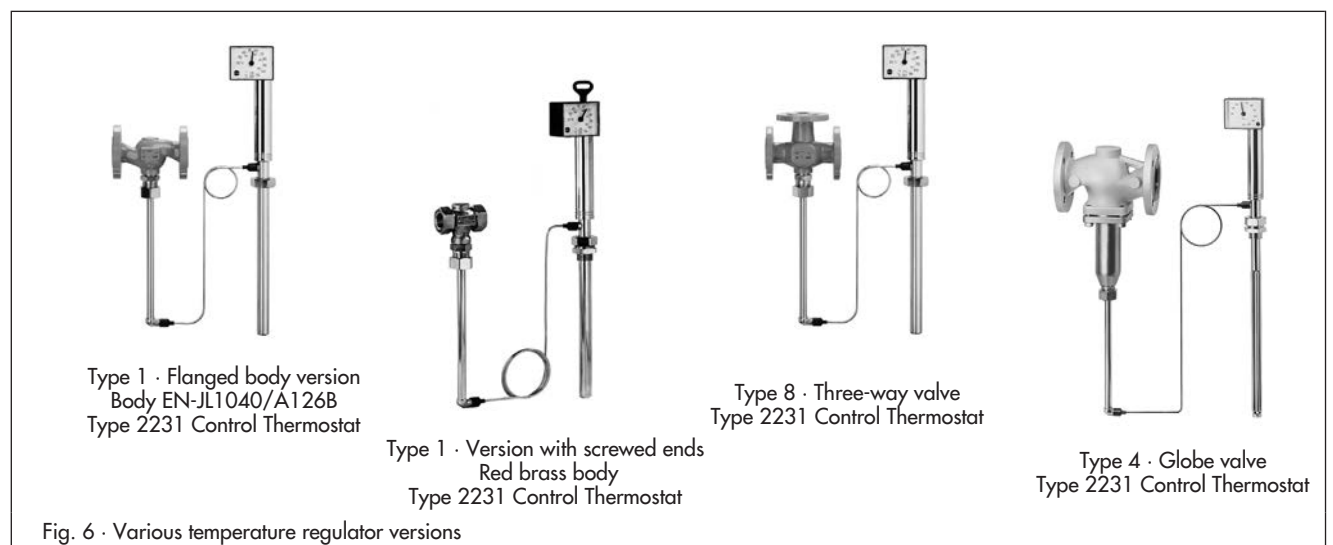

Regulators for cooling installations

Type 4u · Flange connections

Same as Type 4, but equipped with a reversing device · The valve opens as the temperature rises

Technical data **Data Sheets T 2123 EN/T 2650 EN**

See Type 4

Type 1u Temperature Regulator · Screwed ends/flange connections

With unbalanced Type 2121 Single-seated Globe Valve · DIN version: body made of either red brass or spheroidal graphite iron, ANSI version: body made of either cast steel or cast iron The valve opens as the temperature rises · Type 2231 to Type 2235 Control Thermostats

Technical data **Data Sheets T 2113 EN · T 2114 EN**

Set points	-10 to +250 °C · 15 to 480 °F
Screwed ends	
Female thread	G ½ to G 1
Flange connections	
Nominal size	DN 15 to 50 · NPS ½ to 2
Nominal pressure	PN 25 · Class 125, 150 and 300
Temperatures	
Gases	Up to 80 °C · Up to 175 °F
Liquids	Up to 150 °C · Up to 300 °F

Combined devices

Type 1, Type 4, Type 8 and Type 9 Regulators allow a manual adjuster or a double adapter to be installed between the thermostat and the valve. The double adapter allows a second thermostat to be attached to the valve. For details, see Data Sheet T 2036 EN.

Typetested temperature regulators (TR), safety temperature monitors (STM), safety temperature limiters (STL) and combinations of these devices (e.g. TR+STM) for sizes DN 15 to 150 (NPS ½ to 6) and limit signals up to max. 170 °C (340 °F) are used as safety equipment in heat generating systems. All versions can be used with a three-way valve in place of the globe valve.

For details, refer to Information Sheet T 2040 EN and the Data Sheets T 2043 EN and T 2046 EN.

Thermowells and fastening elements

For Type 2231 and Type 2232 Control Thermostats and Type 2212 and Type 2213 Safety Thermostats, thermowells with threaded connections or flanges are available.

For Type 2233 and Type 2234 Control Thermostats, flanges, clamps and perforated covers are available for wall mounting.

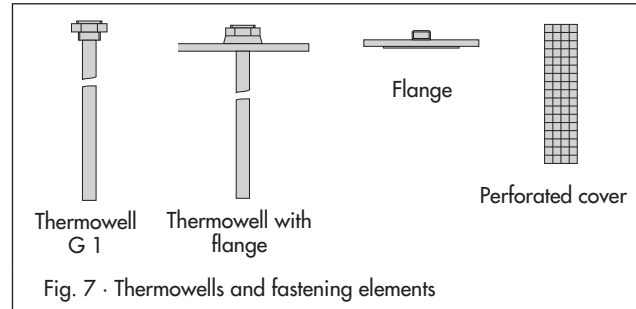

Accessories

If the operating conditions affect the reliability of the operating element, an extension piece and/or separating piece can be mounted between the valve and the operating element.

The extension piece is needed for valves in nominal sizes DN 15 to 100 (NPS ½ to 4) when temperatures above 220 °C (430 °F) occur.

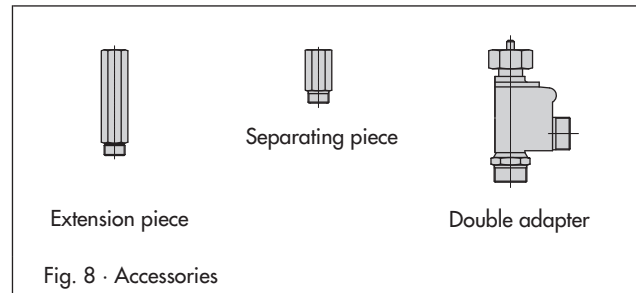

The separating piece in the stainless steel version isolates the non-ferrous metal parts of the operating element from the medium flowing through the valve. In addition, it prevents medium leakage while the thermostat is being replaced.

The double adapters are especially suited for the attachment of a second control thermostat to the regulator. For details, see Data Sheet T 2036 EN.

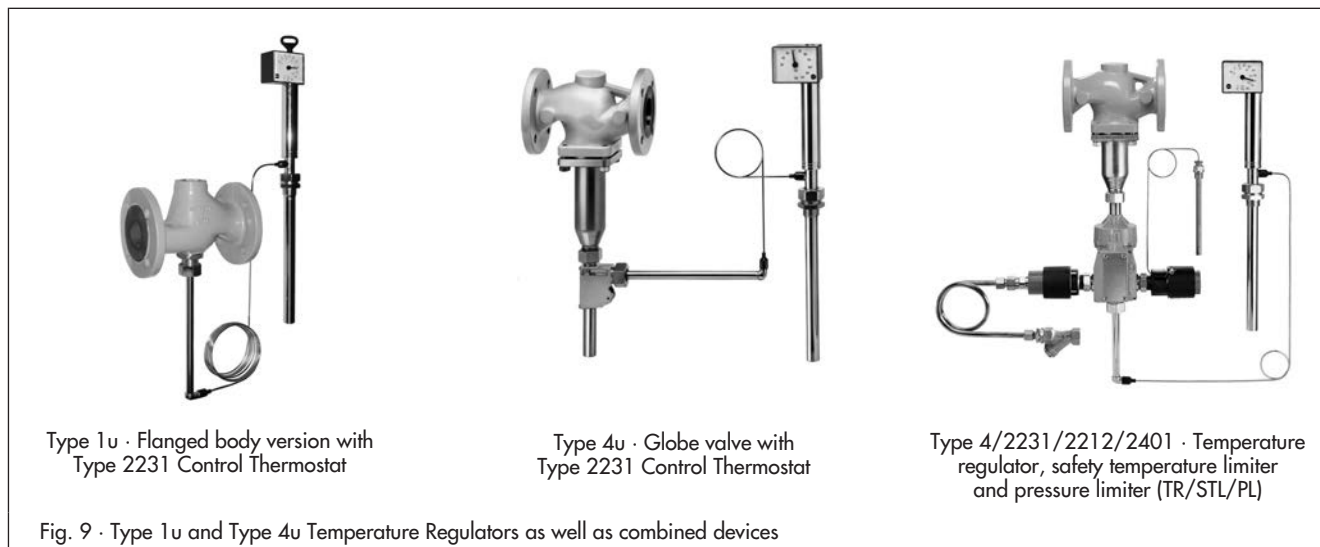

Typical applications

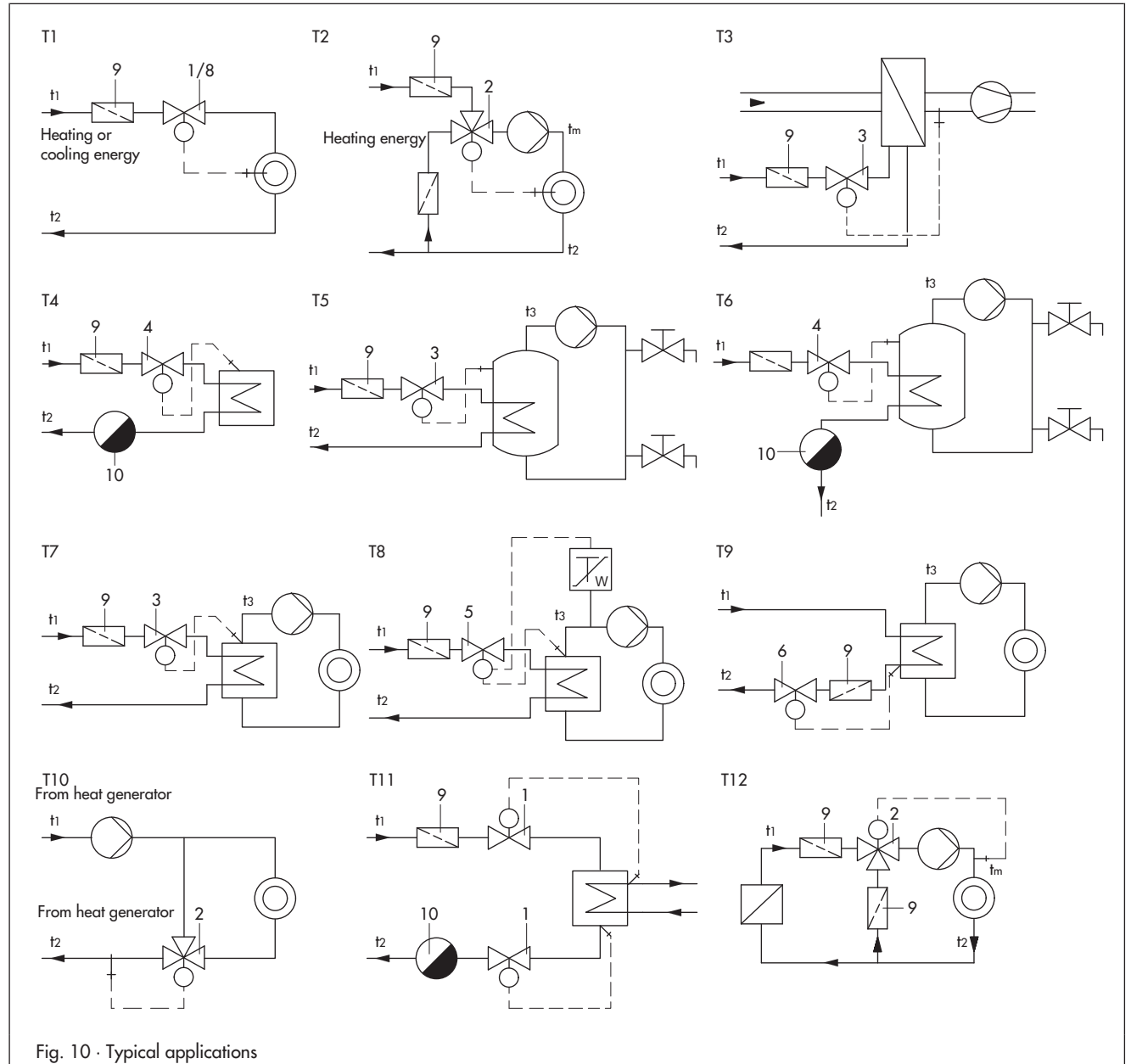

Fig. 10 · Typical applications

Temperature control for different services

- T1 Heating or cooling with a globe valve
- T2 Heating with a three-way valve (mixing valve)
- T3 Control of a water-heated air duct
- T4 Control of a steam-heated drying cabinet, drying room or storage room

Temperature control for boilers, heat generators and heat transfer devices

- T5 Control of a water-heated boiler
- T6 Control of a steam-heated boiler
- T7 Control at a heat generator or heat exchanger
- T8 Temperature control safeguarded by a safety temperature monitor on a heat generator or water-heated heat exchanger

Temperature control in district heat supply systems and cooling systems

- T9 Return flow temperature limitation
- T10 Return flow temperature increase in a boiler system

T11 Temperature control of a condenser

T12 Control of the coolant circuit in motors and compressors

Legend for the examples of application

- 1 Types 1, 1u, 4, 4u
- 2 Types 8, 9
- 3 Types 1, 4 with Type 2233 or Type 2234 Thermostat
- 4 Types 1, 4 with Type 2235 Thermostat
- 5 Types 1, 4 with Type 2231 Thermostat and Type 2212 Safety Thermostat
- 6 Types 1, 4
- 8 Types 1u, 4u
- 9 SAMSON strainer
- 10 SAMSON steam trap

For other examples of application of type-tested devices, refer to Information Sheet T 2040 EN

Specifications subject to change without notice



SAMSON AG · MESS- UND REGELTECHNIK
Weismüllerstraße 3 · 60314 Frankfurt am Main · Germany
Phone: +49 69 4009-0 · Fax: +49 69 4009-1507
Internet: <http://www.samson.de>

T 2010 EN

2012-06