

Self-operated Temperature Regulators

Typetested Safety Devices

Type 1/..., 4/..., 8/..., 9/...



Application

Control, limitation, safety monitoring and safety limitation of the energy supplied to heat generators or heat exchangers which must be equipped with typetested devices.

The safety devices are used to control and protect indirectly heated heat generators in heating and service water heating installations.

Note

Typetested devices are available for installations complying with DIN 4747, DIN EN 12828, DIN EN 12953-6 and DIN 4753.



The temperature regulators, temperature limiters, safety temperature monitors and safety temperature limiters are compulsory according to the relevant regulations (e.g. DIN 4747, DIN EN 12828, DIN EN 12953-6 and DIN 4753) for installations with heat generators or heat exchangers which are heated by steam, hot liquids or by district heating systems. These devices must be tested for reliability and certified accordingly. Therefore the devices listed in this Information Sheet have been tested by TÜV (German Technical Inspectorate) and licensed with a register number.

Device designation

The designation of safety devices is stipulated in DIN 3440 (thermostats and temperature limiters for heat generating systems). The temperatures specified in Figs. 1 to 5 are intended only as a guide to the typical application ranges of the devices shown. The devices needed in each case must meet the requirements of the installation and comply with the relevant safety regulations.

Temperature Regulators (TR), which are typetested, are necessary in many installations. They constantly measure the temperature as a controlled variable, compare it with a given set point, adjust the actual temperature to the set point and interrupt the energy supply when the temperature exceeds the set point.

Safety Temperature Monitors (STM) interrupt the energy supply when the temperature reaches the adjusted limit value, when the capillary tube ruptures or when there is a leak in the sensor (Fig. 3). They reset themselves automatically when the temperature has fallen below the limit value and the fault has been corrected.

Safety Temperature Limiters (STL) interrupt and block the energy supply when the temperature reaches the adjusted limit value, when the capillary tube ruptures or when there is a leak in the sensor (Figs. 4 and 5). They can only be reset and put back into operation with a tool when the temperature has fallen below the limit and the fault has been corrected.

Pressure Limiters (PL) interrupt and block the energy supply when the pressure reaches the adjusted limit value. They can only be reset and put back into operation when the pressure has fallen below the limit and the fault has been corrected.

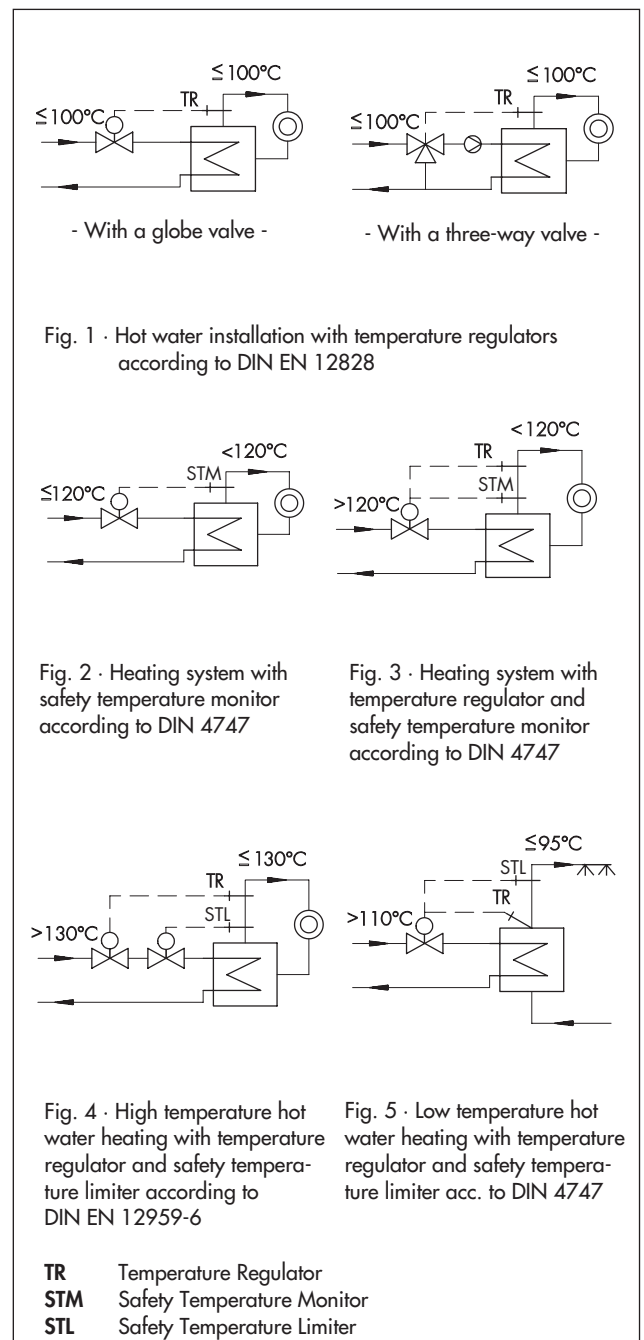

Associated Data Sheets

T 2111 EN, T 2112 EN, T 2113 EN, T 2121 EN, T 2123 EN, T 2131 EN, T 2133 EN, T 2043 EN, T 2046 EN

Edition June 2006

Information Sheet

T 2040 EN

Typetested Safety Devices

Versions for DN 15 to DN 150 · PN 16 to PN 40 · Limit values up to 120 °C

The temperature sensors of the regulators and limiters function according to the liquid expansion principle or the adsorption principle. The temperature-dependent pressure change in the sensor causes the valve plug position to change, thus changing the flow rate of the heating medium. Safety devices are available with globe or three-way valves.

Dynamic behavior of temperature sensors

The regulator's dynamics basically depends on the response behavior of the sensor with its characteristic time constant.

Table 2 shows the time constants of SAMSON thermostats working according to different operating principles measured in water.

Temperature Regulators (TR) (Fig. 6)

These devices consist of a Type 2231, 2232, 2233, 2234 or 2235 Control Thermostat and a Type 2111, 2114, 2118 or 2119 Valve.

They control the temperature and interrupt the energy supply when the temperature exceeds the adjusted set point.

Typetested Regulators

Typetested Temperature Regulators (TR) are available. The register number is available on request.

Safety Temperature Monitors (STM) (Fig. 7)

These devices consist of a Type 2213 Safety Thermostat and a Type 2111, 2114, 2118 or 2119 Valve.

The safety thermostat does not only close the valve when the temperature reaches its limit value, adjustable between 0 to 100 °C or 20 to 120 °C, but also when the capillary tube ruptures or when there is a leak in the sensor. It resets itself automatically when the fault has been removed and the temperature has fallen below the limit.

Table 1 · Overview of temperature regulators

Type ...	With Type ... Valve · DN/G	Data Sheet
1/...	2111 · DN 15 to 50	T 2111 EN
	2111 · G ½ to 1	T 2112 EN
1 u/...	2121 · DN 15 to 50/G ½ to 1	T 2113 EN
4/...	2114 · DN 15 to 250	T 2121 EN
4 u/...		T 2123 EN
8/...	2118 · DN 15 to 50	T 2131 EN
9/...	2119 · DN 15 to 150	T 2133 EN

Table 2 · Time constants of SAMSON thermostats

Operating principle	Type ... Control Thermostat	Time constant in seconds	
		Without thermowell	With thermowell
Liquid expansion	2231	70	120
	2232	65	110
	2233	25	-1)
	2234	15	-1)
	2235	10	-1)
	2213	70	120
Adsorption	2212	-1)	40

1) Not permissible

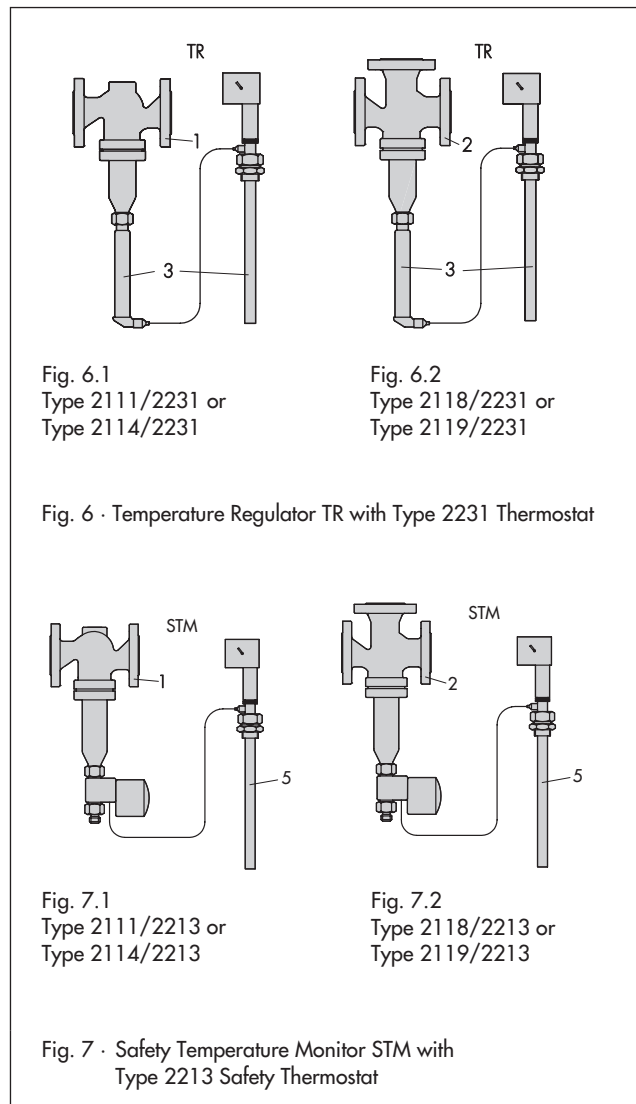

Combination of Temperature Regulator TR with Safety Temperature Monitors (STM) (Fig. 8)

The attached control thermostat takes on the task of a temperature regulator TR in the TR/STM combination. A three-way valve can be used instead of a globe valve also in this version.

Typetested Regulators

Typetested Safety Temperature Monitors with a Type 2213 Safety Thermostat are available. The register number is available on request.

Refer to Data Sheet T 2043 EN for further details.

Safety Temperature Limiters (STL) (Fig. 9)

These devices consist of a Type 2212 Safety Thermostat and a Type 2111, 2114, 2118 or 2119 Valve.

The spring mechanism in the safety thermostat closes and locks the valve when the temperature reaches the limit value, adjustable within the range between 40 and 95 °C or between 70 and 120 °C, when the capillary tube ruptures or when there is a leak in the sensor. The additional electromagnetic release device or the attachable pressure element closes and locks the valve when the safety interlock circuit is interrupted, when the temperature exceeds the adjusted limit value or when the device or the power fails.

It can only be reset and put back into operation with a special tool when the temperature has fallen below the limit value and the fault has been removed.

Combination of Temperature Regulator TR ... with Safety Temperature Limiter STL (TR/STL) with Safety Temperature Limiter STL and Pressure Limiter PL (TR/STL/PL)

The control thermostat, additionally attached to the safety thermostat, functions in the combinations TR/STL (Fig. 10) and TR/STL/PL (Fig. 11) as a temperature regulator (TR) and the pressure element (Type 2401) as a pressure limiter (PL).

The globe valve can be replaced by a three-way valve in all versions.

The register number of the typetested version is available on request; with:

Type 2212 Safety Thermostat

Type 2401 Pressure Element.

Refer to Data Sheet T 2046 EN for further details.

Extended safety according to DIN 3440

Safety temperature monitors (STM) and safety temperature limiters (STL) are designed for "Extended Safety" according to DIN 3440, since they are also effective even when a defect occurs.

Legend for Figs. 6 to 11

- 1 Type 2111 or Type 2114 Globe Valve
- 2 Type 2118 or Type 2119 Three-way Valve
- 3 Type 2231 Control Thermostat (optionally also Type 2232, Type 2233, Type 2234 or Type 2235)
- 5 Type 2213 Safety Thermostat
- 7 Type 2212 Safety Thermostat
- 8 Type 2401 Pressure Element
- 10 Optional electric signal transmitter or electromagnetic release device

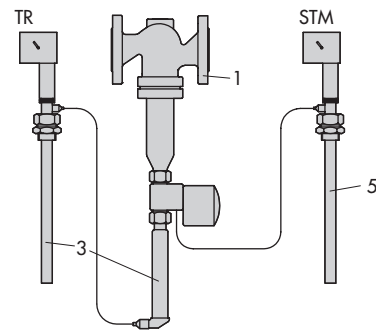

Fig. 8 · Temperature Regulator and Safety Temperature Monitor (TR/STM) with Type 2231 Control Thermostat and Type 2213 Safety Thermostat, Type 2114/2231/2213

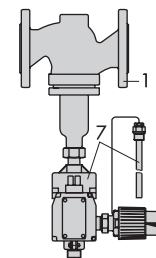

Fig. 9 · Safety Temperature Limiter STL with Type 2212 Safety Thermostat, Type 2111/2212 or Type 2114/2212

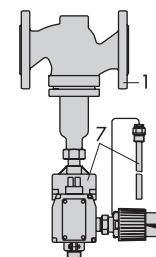

Fig. 10 · Temperature Regulator and Safety Temperature Limiter (TR/STL) with Control and Safety Thermostat Type 2114/2231/2212

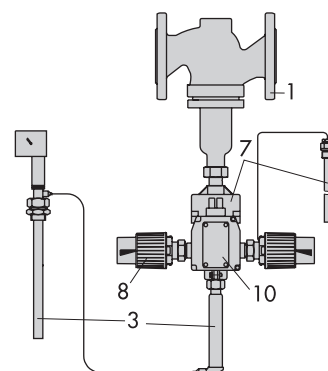

Fig. 11 · Temperature Regulator, Safety Temperature Limiter and Pressure Limiter (TR/STL/PL), Type 2114/2231/2212/2401

Special version

The safety temperature limiters and pressure limiters are equipped optionally with an electric signal transmitter and/or an electromagnetic release device.

The signal transmitter contains a microswitch (max. permissible load: 230V~, 10 A at ohmic load) which provides a limit signal when the temperature has exceeded the limit value or the sensor fails (capillary tube rupture).

The solenoid of the electromagnetic release device is connected in a safety interlock circuit. It is energized in normal operation. When the safety interlock circuit is interrupted the solenoid is de-energized and releases the spring mechanism via a lever, which closes the valve.

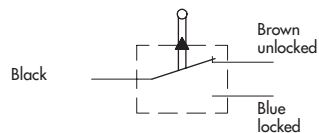

Fig. 12 · Circuit diagram of the signal transmitter

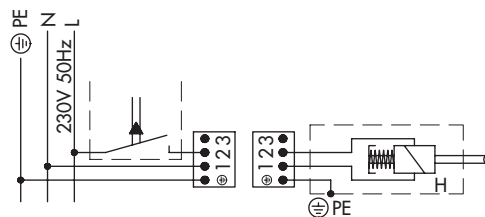

Fig. 13 · Circuit diagram of the electromagnetic release device

Specifications subject to change without notice.



SAMSON AG · MESS- UND REGELTECHNIK
Weismüllerstraße 3 · 60314 Frankfurt am Main · Germany
Phone: +49 69 4009-0 · Fax: +49 69 4009-1507
Internet: <http://www.samson.de>

T 2040 EN