

Self-operated Temperature Regulators

Series 43

Temperature Regulators with Hydraulic Controller

Type 43-8

Type 43-8 N

SAMSON

Application

Temperature regulation of instantaneous water heaters in small district heating units, particularly in single- and two-family dwellings · Valve closes when temperature increases



The regulators are suitable for use with plate heat exchangers for domestic hot water (DHW) heating, particularly in small residential units. Fast-responding thermostats regulate the water temperature to the desired value without delay while the hydraulic control element closes the control valve immediately after tapping has been completed. This prevents the heated DHW from reheating. In addition, temperature peaks do not occur any longer and thus scaling (lime deposits) in the heat exchanger are avoided.

Moreover, the regulator switches to a reduced idle temperature that prevents the heating water supply lines from cooling off. This ensures that hot water is immediately available for the next tapping.

The connections available as accessories enable operation with or without circulation of the heated DHW.

Special features

- Low-maintenance P-regulators requiring no auxiliary energy
- Regulation of small instantaneous water heaters
- Compact design
- Simple installation and operation
- Prevention of temperature peaks and reduction of loss during idle operation (reduced idle temperature)
- Stable regulation already at tapped quantity of 2 l/minute
- Idle temperature regulation
- Fast-responding vapor pressure thermostats

Versions

The **Type 43-8** and **Type 43-8 N Regulators** function the same way, the only difference between them being that the technical features of the Type 43-8 N have been tailored to the requirements of local heat supply networks. Its overall height is approx. 20 mm lower than that of the Type 43-8. As a result, the regulators are *not* interchangeable.

The regulators consist of a control thermostat (vapor pressure thermostat), a hydraulic control element, and a valve. They can additionally be equipped with a Type 2439 K Safety Temperature Limiter.



Fig. 1 · Type 43-8 Temperature Regulator with Hydraulic Controller (regulator including accessories and indicated heat exchanger)

Type 43-8 (43-8 N)

Type 2430 K Vapor Pressure Thermostat · Set point range 45 to 65 °C · In combination with **Type 2432 K Valve (2432 N)** Red brass or hot-pressed brass body · DN 15 · PN 25 (PN 16) · Suitable for liquids up to 130 °C (120 °C) · Permissible differential pressure $\Delta p = 20$ bar (4 bar) · $K_{VS} = 2.5$ · Sensor made of CrNiMo steel · Observe mounting position!

Type 2438 K Hydraulic Controller · Red brass body · Idle temperature approx. 8 K (optionally 1.5 K) below adjusted set point · Required differential pressure at control element 0.4 to 0.6 bar · PN 16

Principle of operation (see Fig. 2)

Fast-responding vapor pressure sensors are used to regulate the temperature of instantaneous water heaters.

The temperature of the heated DHW creates a pressure in the sensor that corresponds to the actual value. This pressure is transferred through the capillary tube (8) to the operating element (13) and converted into a positioning force, which is compared to the force of the set point spring (10). The force ratio causes the plug in the valve (1) to move.

Depending on the travel, an annular gap forms between the seat (2) and the plug (3) that determines the flow rate of the heating water. A temperature increase at the sensor causes the valve plug to close, thus reducing the flow rate of the heating water.

Upon tapping hot water, a pressure difference of $\Delta p = p_1 - p_2$ is created above the baffle plate (6). The resulting force opposes the force of the compression spring (7) that acts in closing direction and causes the valve (1) to open. Once hot water tapping has been completed, the pressure balance is restored. The force of the compression spring causes the valve plug to move in closing direction and the heat flow is interrupted. At the same time, the temperature set point of the thermostat drops by approx. 8 K (optionally 15 K) to reach the reduced idle temperature. As a result, reheating with temperature peaks as well as cooling off of the supply lines is prevented. Hot water is immediately available for the next tapping.

Vapor pressure thermostat

Thermostat operating according to the vapor pressure principle. Due to the fast response time of approx. 3 s, these thermostats are particularly suitable for use in plate heat exchangers ¹⁾.

¹⁾ Other versions on request

Installation

The sensor must be installed in the best possible location to make ideal use of the thermostat's fast response. With plate heat exchangers, this location is directly upstream of the heat exchanger's hot water outlet.

- Install the temperature sensor such that the sensor reaches horizontally into the hot water duct when the heat exchanger is mounted, observing a maximum deviation of $\pm 5^\circ$ from the horizontal position. The notch at the end of the sensor must point upward (see View A).
- Only install the sensor without thermowell.
- Observe a distance of approx. 5 mm between the tip of the sensor and the rear of the housing.
- Install the plate heat exchanger such that the heating water flows vertically between the plates.
- The heat exchanger connections for cold water and the (district) heating water return pipe are located at the bottom; the connections for hot water and the (district) heating water flow pipe can be found at the top.
- The ambient temperature at the set point adjuster must not exceed 35 °C.

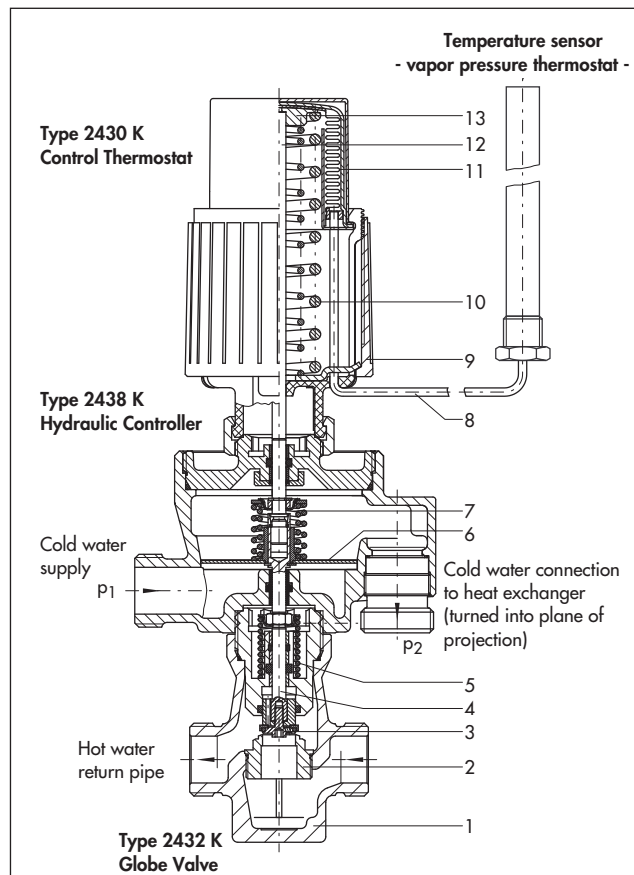

- | | |
|----------------------|-----------------------------|
| 1 Valve body | 7 Compression spring |
| 2 Seat (replaceable) | 8 Capillary tube |
| 3 Plug | 9 Set point adjuster |
| 4 Plug stem | 10 Set point spring |
| 5 Valve spring | 11 Positioning bellows |
| 6 Baffle plate | 12 Pin of operating element |
| | 13 Operating element |

Fig. 2 · Principle of operation

Principle of operation · Vapor pressure thermostat

The temperature sensor is filled with a liquid that vaporizes depending on the temperature. In the sensor, a pressure proportional to the temperature is created. The pressure is transmitted through the capillary tube onto the positioning bellows and converted into a positioning force, which causes the valve plug to move depending on the adjusted set point.

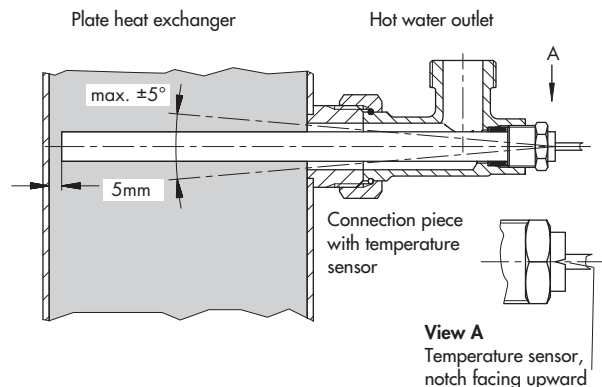

Fig. 3 · Installing the sensor

Table 1 · Technical data

Type 2432 Valve	Type 43-8	Type 43-8 N
Nominal size	DN 15	
Kvs	2.5	
Nominal pressure	PN 25	PN 16
Max. perm. differential pressure	20 bar	6 bar
Max. perm. valve temperature	130 °C	120 °C
Type 2430 K Control Thermostat ¹⁾		
Set point range	45 to 65 °C	
Capillary tube	2 m (special version: 5 m)	
Max. perm. temperature at sensor	30 K above adjusted set point	
Max. perm. temperature at set point adjuster	35 °C	
Perm. pressure at sensor	PN 40	
Type 2438 K Hydraulic Controller		
Required differential pressure at control element on the cold water side	0.4 bar with a tapping rate up to 10 l/minute 0.5 bar with a tapping rate up to 20 l/minute	
Nominal pressure	PN 16	
Idle temperature	Approx. 8 K (optionally 15 K) below adjusted set point	
Min. temperature difference between flow temperature and temperature set point	10 K	
Max. flow rate	20 l/minute	

¹⁾ In addition to a Type 2430 K Control Thermostat, a Type 2439 K Safety Temperature Limiter can be used. Observe changed dimensions!

Table 2 · Materials · Material numbers according to DIN EN

Body	CC491K (red brass Rg 5)	CW602N (hot-pressed brass)
Valve seat	Stainless steel 1.4305	CW602N
Valve plug	1.4104 and dezincification-resistant brass with EPDM soft sealing	
Valve spring and spring in Type 2438 K	Stainless steel 1.4310	
Baffle plate	1.4301	
Temperature sensor	Capillary tube	Copper
	Sensor	CrNiMo steel
Set point adjuster	Glass fiber reinforced PETP	

Field of application

The quality of the domestic water to be controlled determines the field of application of the regulator. The water quality shall meet the requirements specified in Table 3.

Table 3 · Water quality

Domestic water	
pH	Min. 7/max. 10
Chloride concentration	Max. 150 mg/l
$\frac{HCO_3^-}{SO_4^{2-}}$	>1.5
Carbonate hardness	Min. 5° dH (German hardness)
Total hardness	Max. 12° dH (German hardness)

Domestic hot water heated in an instantaneous heating system with Type 43-8

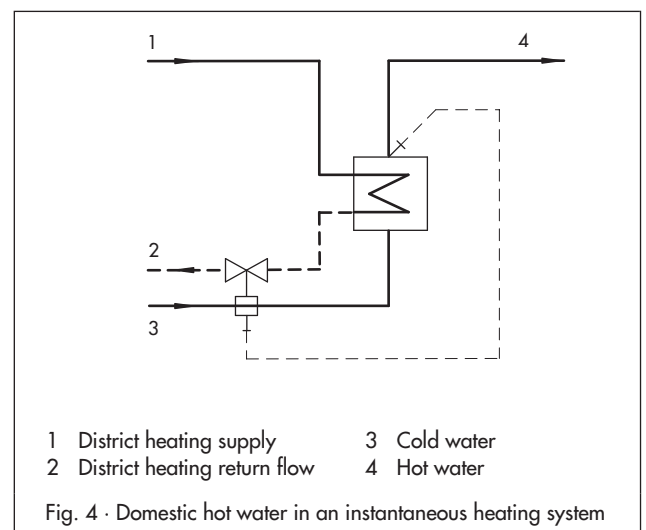

Accessories

Connection piece (1) to hot water tapping point (G ¾ or G 1)
With/without sensor pocket (G ¾ or G 1) · Including flat gasket
For temperature sensor Ø 12, Rg 5

Cold water supply · Corrugated pipe (4) with/without circulation pipe connection (2) for connection to heat exchanger (G ¾ or G 1)
Including flat gasket

Hot water return pipe · Double nut (5) of brass (G ¾ or G 1) for connection to heat exchanger · Welding end (3) with connection nut
Including flat gasket

Connection dimensions for heat exchanger

Heat exchanger connection	G ¾	G 1
Double nut (5)		
Distance "a" in mm	40 to 45	48 to 52 69 to 73
Corrugated pipe (4) connection	With/without circulation	

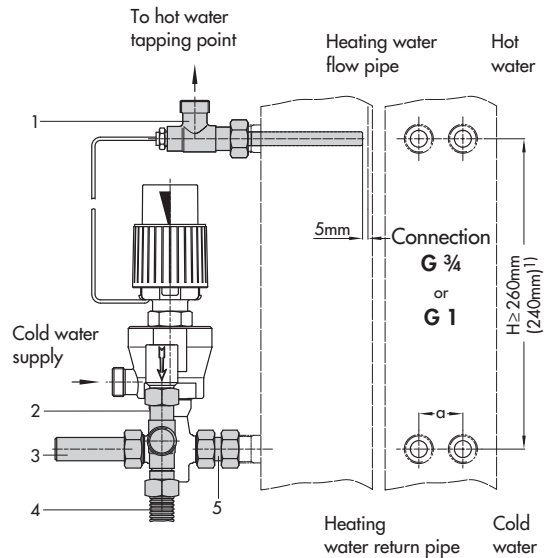
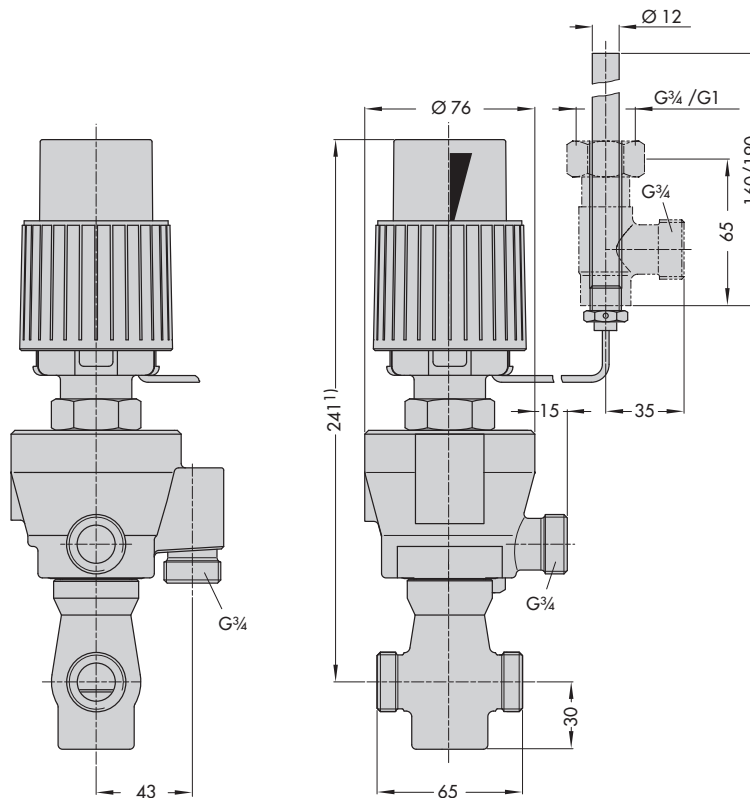

Fig. 5 · Regulator with accessories

¹⁾ For Type 43-8N

Dimensions in mm



¹⁾ For Type 43-8 N: 221 mm
With Type 2439 K Safety Temperature Limiter: 361 mm

Fig. 6 · Dimensions

Ordering text

Temperature Regulator with Hydraulic Controller
Type 43-8/Type 43-8 N · Valve DN 15, K_{VS} 2.5
Heat exchanger Type ...

Heat exchanger connection G ¾/G 1

With/without circulation pipe connection

Sensor (160 or 190 mm) with/without screw gland

Optionally, special version ...

Optionally, accessories ...

Specifications subject to change without notice.



SAMSON AG · MESS- UND REGELTECHNIK
Weismüllerstraße 3 · 60314 Frankfurt am Main · Germany
Phone: +49 69 4009-0 · Fax: +49 69 4009-1507
Internet: <http://www.samson.de>

T 2178 EN

2012-05