

Self-operated Pressure Regulators

Steam Pressure Reducing Valve Type 39-2



Application

Set points from **0.02 bar** to **16 bar** · Valves in **DN 15** to **DN 50**
Nominal pressure **PN 16** and **PN 25** · Suitable for steam up to
max. **350 °C**



The Type 39-2 Steam Pressure Reducing Valve regulates the steam pressure downstream from the valve to an adjusted set point.

The valve closes when the downstream pressure rises.

Special features

- Low-maintenance P-regulators requiring no auxiliary energy
- Actuator and springs are exchangeable
- Single-seated valve with balanced valve plug and a frictionless plug stem sealing by means of a stainless steel bellows
- All wetted parts are free of non-ferrous metal

Versions

Type 39-2 Steam Pressure Reducing Valve:

Valve body made of cast iron, spheroidal graphite iron or cast steel · Actuator (with EPDM rolling diaphragm) · With condensation chamber and screw fitting · For steam temperatures up to 350 °C.

Special version

With St I flow divider for especially low-noise operation. For details, see Data Sheet T 8081 EN. When the flow divider St I is retrofitted, the valve seat must be replaced.

ANSI versions are available on request.

Accessories (refer to T 2595 EN)

Screw fitting for the control line connection

Condensation chamber with funnel tube for collecting condensate and as a temperature safeguard

Conical expansion piece, nominal pressure PN 16 or PN 40

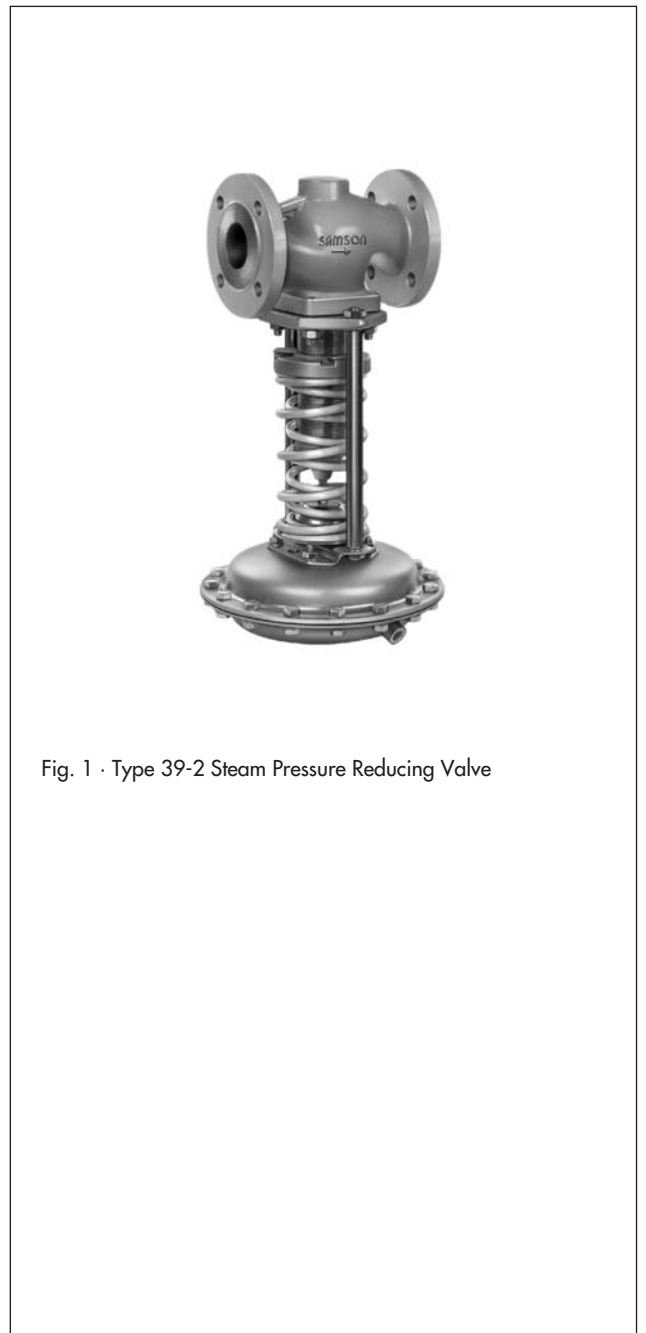

Fig. 1 · Type 39-2 Steam Pressure Reducing Valve

Principle of operation (Fig. 2)

The process medium flows through the valve in the direction indicated by the arrow. The position of the valve plug (3) determines the flow rate between the free area between the plug (3) and seat (2). The downstream pressure (p_2) to be controlled is transmitted via a control line (14) to the operating diaphragm (13) where it is converted into a positioning force. This force adjusts the valve plug as a function of the spring force. The spring force can be adjusted using the set point adjustment (6).

The balanced valves are equipped with a stainless steel bellows (4). The upstream pressure (p_1) is applied to the outside bellows surface. As a result, the forces created by the upstream pressure and acting on the valve plug are balanced out. The downstream pressure is balanced via the diaphragm area in the actuator.

Installation

Install the valves in horizontal pipelines with a slight downward slope on both sides of the valve for drainage of the condensate (refer to EB 2506 EN for more details).

- The direction of medium flow must correspond with the arrow on the valve body.
- The actuator must be suspended downwards.
- Pressure tapping approx. one meter downstream of the valve. The control line (3/8" pipe) is mounted on site and not included in the scope of delivery.
- A conical expansion piece can be used to double the nominal outlet diameter (refer to dimensional drawing and accessories).

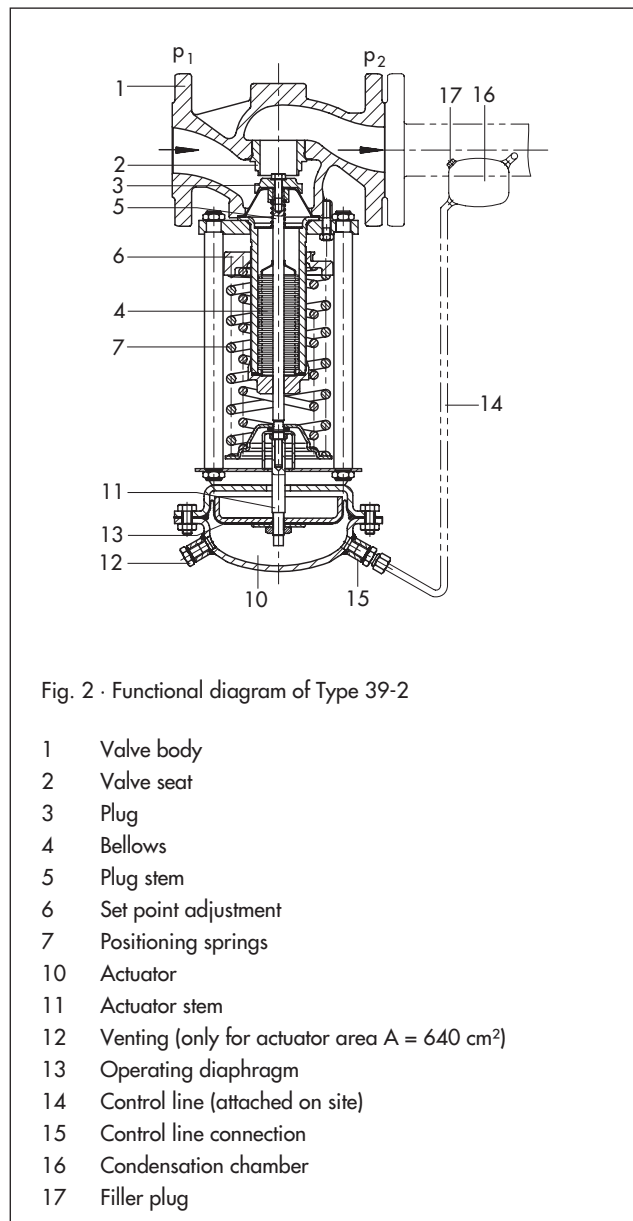

Pressure-temperature diagram – acc. to DIN EN 12516-1 –

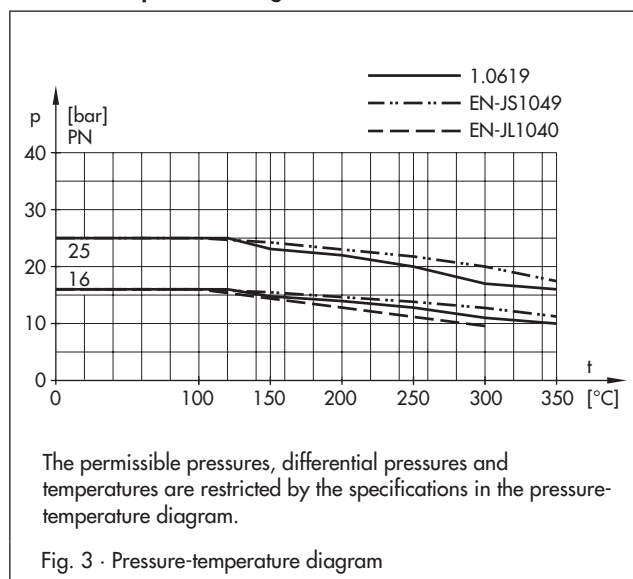

Table 1 · Technical data · All pressures in bar (gauge)

Nominal size	DN 15 to 50
Nominal pressure	PN 16 or 25
Temperature range	See pressure-temperature diagram
Valve plug	Metal sealing · Up to 350 °C
Actuator with condensation chamber	Steam · Up to 350 °C
Max. perm. differential pressure Δp	25 bar
Set point ranges	0.02 to 0.25 bar · 0.1 to 0.6 bar · 0.2 to 1.2 bar · 0.8 to 2.5 bar · 2 to 5 bar · 4.5 to 10 bar · 8 to 16 bar
Leakage rate	≤ 0.05 % of K_{VS} coefficient
Valve spring force F and actuator area A	See Table 4 · Dimensions in mm and weights

Table 2 · Materials · Material number according to DIN EN

Valve			
Nominal pressure	PN 16	PN 25	
Max. perm. temperature	300 °C	350 °C	
Body	Cast iron EN-JL1040 (GG-25)	Spheroidal graphite iron EN-JS1049 (GGG-40.3)	Cast steel 1.0619 (GS-C 25)
Seat and plug	Stainless steel		
Bellows	Stainless steel		
Sealing ring	Graphite with metal core		
Actuator			
Diaphragm cases	Sheet steel 1.0037 (St 37-2)		
Diaphragm	EPDM with fabric reinforcement · Max. perm. ambient temperature 80 °C		

Table 3 · K_{VS} coefficients

Nominal size DN	Seat \varnothing in mm	K_{VS}	K_{VS}^1
		Standard version	With flow divider St I
15	22	4	3
20	22	6.3	5
25	22	8	6
32	40	16	12
40	40	20	15
50	40	32	23

¹⁾ Terms for noise level calculation according to VDMA 24422 (edition 1.89) · $K_{VS}^1 = K_{VS}$ with flow divider St I installed

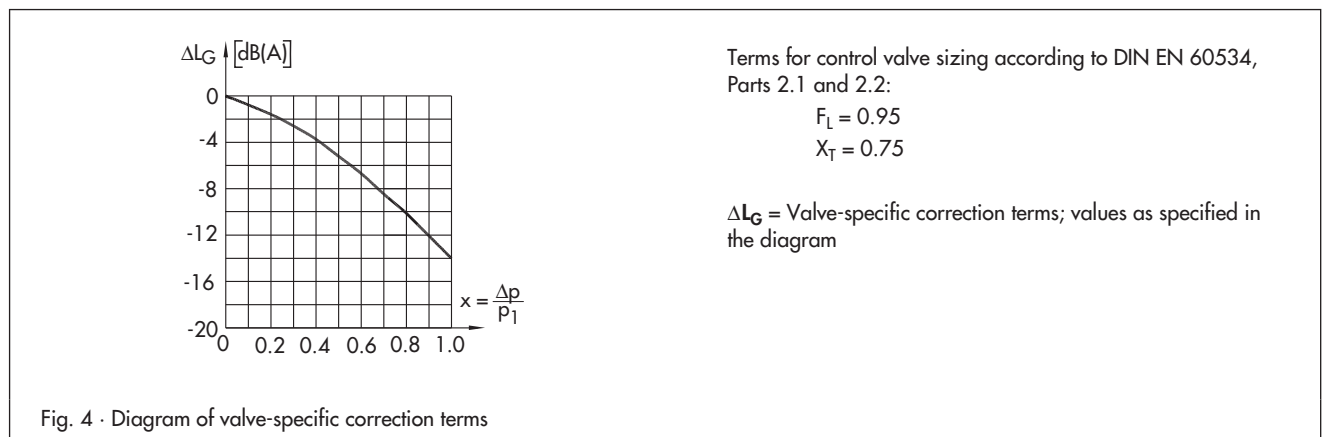

Table 4 · Dimensions in mm and weights

Nominal size		DN	15	20	25	32	40	50
Set point range in bar	Length L (valve)		130	150	160	180	200	230
	L1 (valve + conical expansion piece)	PN 16 PN 25	220	256	278	314	337	380
0.02 to 0.25	Height H		425			480		
	Actuator		Ø D = 380, A = 640 cm ²					
	Valve spring force F		1750 N					
0.1 to 0.6	Height H		425			480		
	Actuator		Ø D = 380, A = 640 cm ²					
	Valve spring force F		4400 N					
0.2 to 1.2	Height H		410			465		
	Actuator		Ø D = 285, A = 320 cm ²					
	Valve spring force F		4400 N					
0.8 to 2.5	Height H		410			465		
	Actuator		Ø D = 225, A = 160 cm ²					
	Valve spring force F		4400 N					
2 to 5	Height H		390			445		
	Actuator		Ø D = 170, A = 80 cm ²					
	Valve spring force F		4400 N					
4.5 to 10	Height H		390			445		
	Actuator		Ø D = 170, A = 40 cm ²			Ø D = 170, A = 80 cm ²		
	Valve spring force F		4400 N			8000 N		
8 to 16	Height H		390			445		
	Actuator		Ø D = 170, A = 40 cm ²					
	Valve spring force F		8000 N					
0.02 to 0.6	Weight for PN 16 ¹⁾ in approx. kg		21	22	22	28	30	34
0.1 to 1.2			16	17	17	22	24	28
0.8 to 2.5			14	15	15	21	22	26
2 to 16			12	13	13	18	21	24

¹⁾ +10 % for PN 25

Dimensional drawing

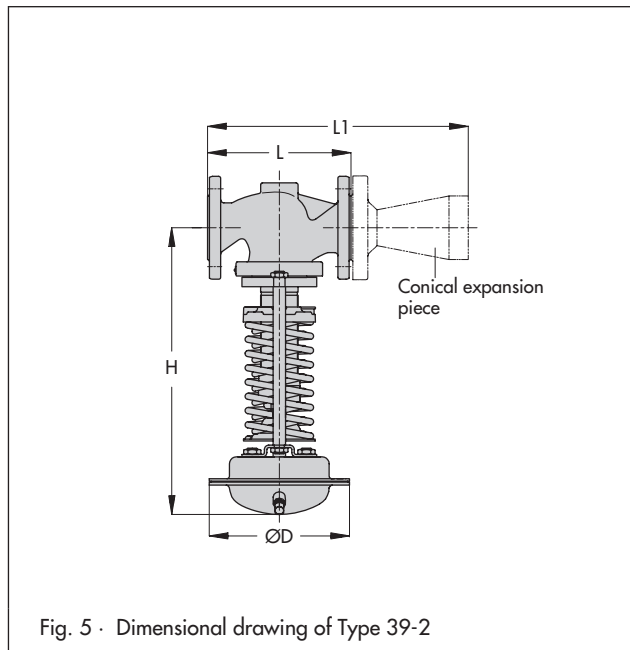

Fig. 5 · Dimensional drawing of Type 39-2

Specifications subject to change without notice.

