

Self-operated Pressure Regulators

Steam Pressure Reducing Valve Type 39-2



ANSI version

Application

Set points from **0.3 psi** to **230 psi (0.02 bar to 16 bar)** · Valves in **NPS ½ to 2** · Pressure rating **Class 125** and **Class 150**
Suitable for steam up to max. **660 °F (350 °C)**

Valve **closes** when the downstream pressure rises



The Type 39-2 Steam Pressure Reducing Valve regulates the steam pressure downstream from the valve to an adjusted set point.

Special features

- Low-maintenance proportional regulators requiring no auxiliary energy
- Actuator and springs are exchangeable
- Single-seated valve with balanced valve plug and a frictionless plug stem sealing by means of a stainless steel bellows
- All wetted parts are free of non-ferrous metal

Versions

Type 39-2 Steam Pressure Reducing Valve:

Valve body made of cast iron A 126 B or carbon steel A 216 WCC · Actuator (with EPDM rolling diaphragm) · With condensation chamber and screw fitting · For steam temperatures up to 660 °F (350 °C)

Special version

With St I flow divider for especially low-noise operation. For details, see Data Sheet T 8081 EN. When the flow divider St I is retrofitted, the valve seat must be replaced.

Accessories (refer to T 2595 EN)

Screw fitting for the control line connection

Condensation chamber with funnel tube for collecting condensate and as a temperature safeguard



Fig. 1 · Type 39-2 Steam Pressure Reducing Valve

Principle of operation (Fig. 2)

The process medium flows through the valve in the direction indicated by the arrow. The position of the valve plug determines the flow rate between the free area between the plug (3) and seat (2).

The downstream pressure (p_2) to be controlled is transmitted via a control line (14) to the operating diaphragm (13) where it is converted into a positioning force. This force adjusts the valve plug as a function of the spring force. The spring force can be adjusted using the set point adjuster (6).

The balanced valves are equipped with a stainless steel bellows (4). The upstream pressure (p_1) is applied to the outside bellows surface. As a result, the forces created by the upstream pressure and acting on the valve plug are balanced out. The downstream pressure is balanced via the diaphragm area in the actuator.

Installation

Install the valves in horizontal pipelines with a slight downward slope on both sides of the valve for drainage of the condensate (refer to EB 2506 EN for more details).

- The direction of medium flow must correspond with the arrow on the valve body.
- The actuator must be suspended downwards.
- Pressure tapping approx. 3.3 feet (1 meter) downstream of the valve. The control line (3/8" pipe) is mounted on site and not included in the scope of delivery.



Flow coefficients

C_{V1} , K_{VS1} and C_{V2} , K_{VS2} for installation of a flow divider St I as a noise-reducing component.

Flow characteristic differences between valves with and valves without flow dividers do not occur until the valve has passed through approx. 80 % of its travel range.

Terms for control valve sizing according to DIN EN 60534, Parts 2.1 and 2.2:

$$F_L = 0.95$$

$$X_T = 0.75$$

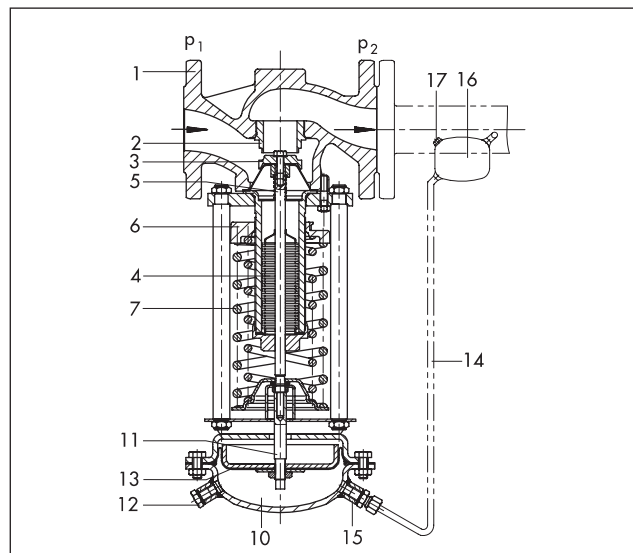

Fig. 2 · Functional diagram of Type 39-2

- | | |
|----|---|
| 1 | Valve body |
| 2 | Valve seat |
| 3 | Plug |
| 4 | Bellows |
| 5 | Plug stem |
| 6 | Set point adjuster |
| 7 | Positioning springs |
| 10 | Actuator |
| 11 | Actuator stem |
| 12 | Venting (only for actuator area $A = 100 \text{ in}^2/640 \text{ cm}^2$) |
| 13 | Operating diaphragm |
| 14 | Control line (attached on site) |
| 15 | Control line connection |
| 16 | Condensation chamber |
| 17 | Filler plug |

Valve-specific correction terms

ΔL_G with gases and vapors. Values as specified in the diagram

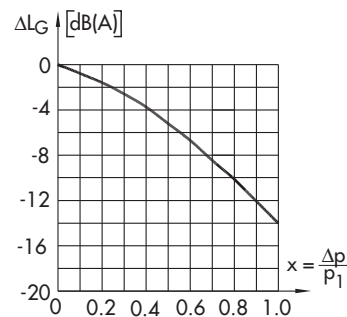

Fig. 3 · Diagram for valve-specific correction terms

Table 1 · Technical data · All pressures specified as gauge pressures

| Nominal size | NPS ½ to 2 |
|---|---|
| Nominal pressure | Class 125 and 150 |
| Temperature range | See pressure-temperature diagram |
| Valve plug | Metal sealing · Up to 660 °F (350 °C) |
| Actuator with condensation chamber | Steam · Up to 660 °F (350 °C) |
| Max. perm. differential pressure Δp | 360 psi (25 bar) |
| Set point ranges | 0.3 to 3.5 psi · 1.5 to 8.5 psi · 3 to 17 psi · 10 to 35 psi · 30 to 75 psi · 65 to 145 psi 115 to 230 psi |
| | 0.02 to 0.25 bar · 0.1 to 0.6 bar · 0.2 to 1.2 bar · 0.8 to 2.5 bar · 2 to 5 bar · 4.5 to 10 bar · 8 to 16 bar |
| Leakage rate | $\leq 0.05\%$ of C_V (K_{VS}) |
| Valve spring force F and actuator area A | See Table 4 · Dimensions in mm and weights |

Table 2 · Materials · Material number according to ASTM und DIN EN

| Valve | | |
|------------------------|--|-----------------------|
| Pressure rating | Class 125 | Class 150 |
| Max. perm. temperature | 570 °F · 300 °C | 660 °F · 350 °C |
| Body | Cast iron A126B | Carbon steel A216 WCC |
| Seat and plug | Stainless steel | |
| Bellows | Stainless steel | |
| Sealing ring | Graphite with metal core | |
| Actuator | | |
| Diaphragm cases | Sheet steel 1.0037 (St 37-2) | |
| Diaphragm | EPDM with fabric reinforcement · Max. perm. ambient temperature 175 °F (80 °C) | |

Table 3 · C_V and K_{VS} coefficients

| Nominal size | | Seat \varnothing | | Flow coefficients ¹⁾ | | | |
|--------------|----|--------------------|----|---------------------------------|----------|------------------------|-----------|
| NPS | DN | inch | mm | Standard version | | With flow divider St I | |
| | | | | C_V | K_{VS} | C_{Vl} | $K_{VS}l$ |
| ½ | 15 | 0.87 | 22 | 5 | 4 | 3.4 | 3 |
| ¾ | 20 | 0.87 | 22 | 7.5 | 6.3 | 6 | 5 |
| 1 | 25 | 0.87 | 22 | 9.4 | 8 | 7 | 6 |
| 1½ | 40 | 1.57 | 40 | 23 | 20 | 18 | 15 |
| 2 | 50 | 1.57 | 40 | 37 | 32 | 26.5 | 23 |

¹⁾ Terms for noise level calculation according to VDMA 24422 (edition 1.89) · C_{Vl} or $K_{VS}l$ = C_V or K_{VS} with flow divider St I installed

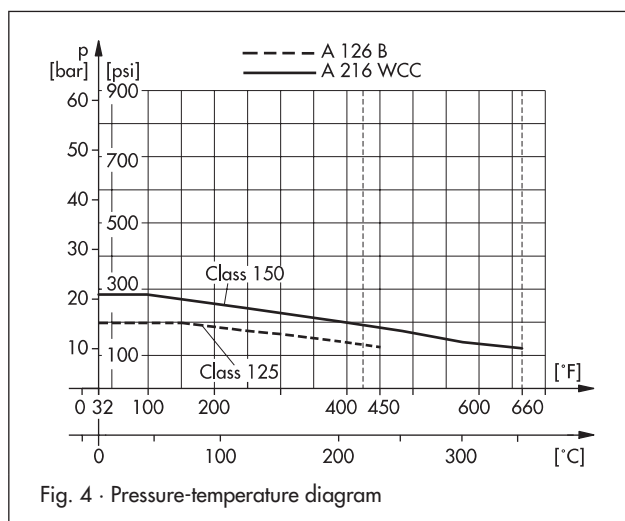

Fig. 4 · Pressure-temperature diagram

Pressure-temperature diagram – Material acc. to ASTM –

The permissible pressures, differential pressures and temperatures are restricted by the specifications in the pressure-temperature diagram.

Table 4 · Dimensions and weights

| Nominal size | | NPS | 1/2 | 3/4 | 1 | 1 1/2 | 2 |
|---------------------------------|--|----------------------|--|------|------|--|-----|
| Length L | Class 125 | inch | – | – | 7.25 | 8.75 | 10 |
| | | mm | – | – | 184 | 222 | 254 |
| | Class 150 | inch | 7.25 | 7.25 | 7.25 | 8.75 | 10 |
| | | mm | 184 | 184 | 184 | 222 | 254 |
| Set point ranges in psi and bar | 0.3 to 3.5 psi 0.02 to 0.25 bar | Height H | 16.7"/425 mm | | | 18.9"/480 mm | |
| | | Diaphragm case | ∅ D = 15.0"/380, A = 100 in ² /640 cm ² | | | | |
| | | Valve spring force F | 1750 N | | | | |
| | 1.5 to 8.5 psi 0.1 to 0.6 bar | Height H | 16.7"/425 mm | | | 18.9"/480 mm | |
| | | Diaphragm case | ∅ D = 15.0"/380 mm, A = 100 in ² /640 cm ² | | | | |
| | | Valve spring force F | 4400 N | | | | |
| | 3 to 17 psi 0.2 to 1.2 bar | Height H | 16.1"/410 mm | | | 18.3"/465 mm | |
| | | Diaphragm case | ∅ D = 11.2"/285 mm, A = 50 in ² /320 cm ² | | | | |
| | | Valve spring force F | 4400 N | | | | |
| | 10 to 35 psi 0.8 to 2.5 bar | Height H | 16.1"/410 mm | | | 18.3"/465 mm | |
| | | Diaphragm case | ∅ D = 8.9"/225 mm, A = 25 in ² /160 cm ² | | | | |
| | | Valve spring force F | 4400 N | | | | |
| | 30 to 75 psi 2 to 5 bar | Height H | 15.4"/390 mm | | | 17.5"/445 mm | |
| | | Diaphragm case | ∅ D = 6.7"/170 mm, A = 12 in ² /80 cm ² | | | | |
| | | Valve spring force F | 4400 N | | | | |
| | 65 to 145 psi 4.5 to 10 bar | Height H | 15.4"/390 mm | | | 17.5"/445 mm | |
| | | Diaphragm case | ∅ D = 6.7"/170 mm, A = 6 in ² /40 cm ² | | | ∅ D = 6.7"/170 mm, A = 12 in ² /80 cm ² | |
| | | Valve spring force F | 4400 N | | | 8000 N | |
| | 115 to 230 psi 8 to 16 bar | Height H | 15.4"/390 mm | | | 17.5"/445 mm | |
| | | Diaphragm case | ∅ D = 6.7"/170 mm, A = 6 in ² /40 cm ² | | | | |
| Valve spring force F | | 8000 N | | | | | |
| 0.3 to 8.5 psi | Weight for Class 125 ¹⁾ , approx. | lb | 47 | 49 | 49 | 67 | 75 |
| 0.02 to 0.6 bar | | kg | 21 | 22 | 22 | 30 | 34 |
| 1.5 to 17 psi | | lb | 36 | 38 | 38 | 54 | 63 |
| 0.1 to 1.2 bar | | kg | 16 | 17 | 17 | 24 | 28 |
| 10 to 35 psi | | lb | 32 | 34 | 34 | 49 | 57 |
| 0.8 to 2.5 bar | | kg | 14 | 15 | 15 | 22 | 26 |
| 30 to 230 psi | | lb | 27 | 30 | 30 | 48 | 54 |
| 2 to 16 bar | | kg | 12 | 13 | 13 | 21 | 24 |

¹⁾ +10 % for Class 150

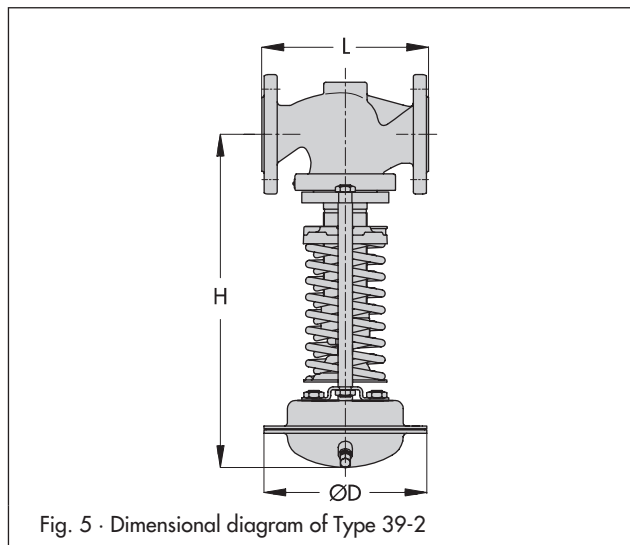

Fig. 5 · Dimensional diagram of Type 39-2

Ordering text

Steam Pressure Reducing Valve Type 39-2
 Nominal size NPS ...
 Class ...
 Set point range ... psi (bar)
 Optionally, accessories ...
 Special version ...

Specifications subject to change without notice

