

Self-operated Pressure Regulators

Pressure Reducing Valve Type M 44-2



Applications

Pressure regulators for set points from **0.005 to 20 bar** · K_{VS} coefficients **0.15 to 22** · Valve sizes **DN 15 to DN 50** · **G ¼ to G 2** · Suitable for liquids and gases up to **130 °C**, steam up to **190 °C/200 °C** · Nominal inlet pressure **PN 16, PN 40, PN 160** ¹⁾, **PN 250** ¹⁾ and **PN 315** ²⁾

The valve closes when the downstream pressure rises

Special features

- Diaphragm-controlled, spring-loaded P-regulators requiring no auxiliary energy
- Particularly favorable control properties, while the offset remains small
- All parts made of CrNiMo steel with smooth surfaces

Versions

Pressure reducing valve with pressure balancing ³⁾ to regulate the downstream pressure p_2 to the adjusted set point. The valve closes when the downstream pressure rises.

K_{VS} coefficient 0.15 · Set points from 0.3 to 20 bar:
Connection DN 15 or G ¼ · Plug with soft sealing · Suitable for liquids and gases up to 130 °C · Unbalanced · Without external control line · For liquids $\Delta p_{max} = 25$ bar

K_{VS} coefficients from 5 to 22 · Set points from 0.02 to 12 bar:
Connection DN 15, 25, 32, 40 and 50 or G ½, G 1, G 1¼, G 1½ and G 2 · Plug with soft sealing · Suitable for liquids and gases up to 130 °C · Steam up to 190 °C · Pressure balanced With external control line (installed on site) · For liquids $\Delta p_{max} = 25$ bar

K_{VS} coefficients 0.2, 0.5, 0.9 and 1.5 · Set points from 0.005 to 12 bar:

Connection DN 15 and DN 25 or G ½ · Plug with metal sealing · Suitable for steam up to 200 °C · Unbalanced · With external control line (installed on site) · For liquids $\Delta p_{max} = 25$ bar

K_{VS} coefficients 0.15, 0.4 and 0.9 · Set points from 0.005 to 20 bar:

Plug with soft sealing · Suitable for liquids and gases up to 130 °C · DN 15 and DN 25 or G ½ · Unbalanced · Without external control line · For liquids $\Delta p_{max} = 25$ bar

Special versions

- Version free of oil and grease for oxygen or high-purity gas
- Version for sterilized steam on request
- Welding neck flanges acc. to DIN EN 1092-1 and ANSI Class 150/Class 300 raised face
- Special connections according to customer specifications

— NPT connections for pressure and control lines

¹⁾ G ½ only: $K_{VS} = 0.2$ and 0.9 for liquids and gases

²⁾ G ¼ only: $K_{VS} = 0.15$

³⁾ Connection G ¼ ($K_{VS} 0.15$) and G ½/DN 15/DN 25 ($K_{VS} 0.2$ to 1.5): Unbalanced

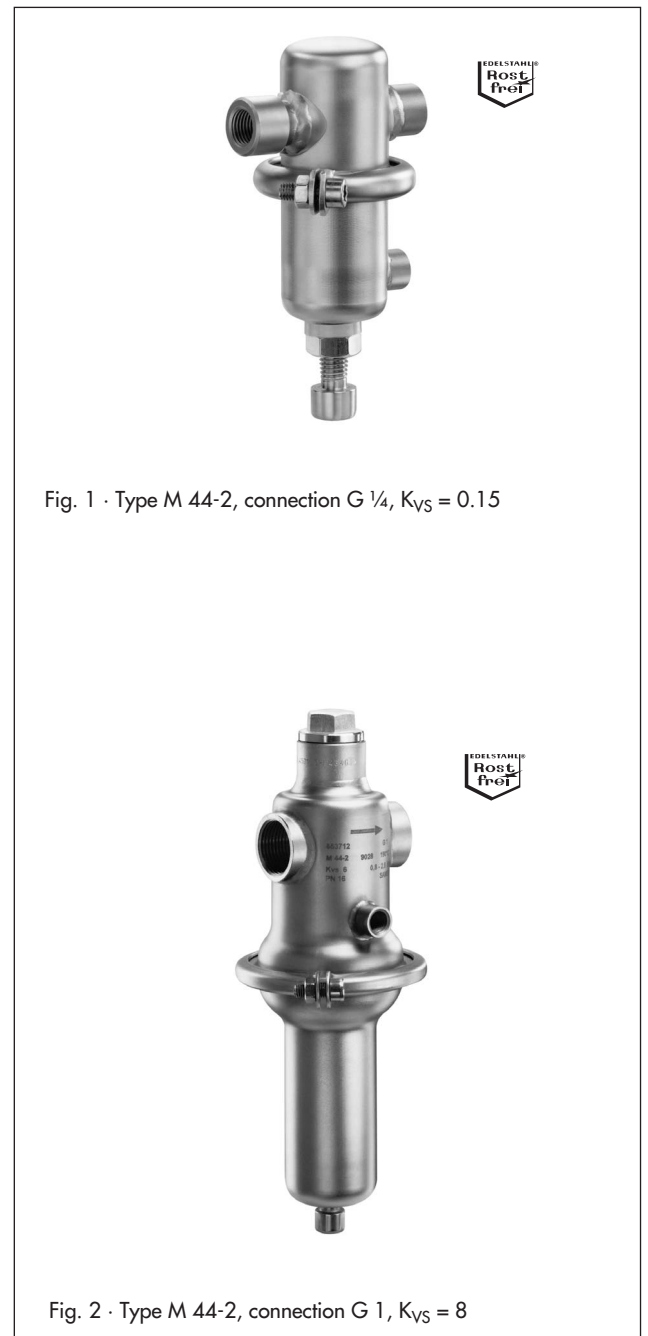

Fig. 1 · Type M 44-2, connection G ¼, $K_{VS} = 0.15$

Fig. 2 · Type M 44-2, connection G 1, $K_{VS} = 8$

Principle of operation

The medium flows through the valve as indicated by the arrow. The position of the valve plug (2) determines the flow rate across the area released between the plug and seat (3). The valve is open when it is relieved of pressure ($p_1 = p_2$).

If there is pressure drop across the valve, the medium flows from the inlet through the valve seat into the body. The downstream pressure p_2 to be regulated is transmitted to the diaphragm where it is converted into a positioning force and balanced against the force of the positioning spring (7). The positioning force is used to adjust the valve plug depending on the spring force, which is adjustable at the set point adjuster (8). If the force resulting from p_2 exceeds the value adjusted at the set point adjuster, the valve plug moves towards the seat, reducing the flow rate and the valve closes.

To keep the influence of disturbance variables relatively small, the force created by the upstream pressure p_1 acting on the plug is compensated for by the balancing bushing (5) ¹⁾.

¹⁾ Versions with $K_{VS} = 0.2$ to 1.5 : Unbalanced

Installation

Type M 44-2: $K_{VS} 0.15$ /set points 0.3 to 20 bar: without external control line

Type M 44-2: $K_{VS} 5$ to 22/set points 0.02 to 12 bar: with external control line (installed on site)

Type M 44-2: $K_{VS} 0.2$ to 1.5 /set points 0.005 to 20 bar: external control line only in version for steam with intermediate piece (13) and for $p_2 \leq 1.1$ bar

On installation, the following must be observed

- Install regulator in horizontal pipeline free of stress. Install regulators for steam with a slight downward slope on both sides for drainage of the condensate.
- The direction of medium flow must correspond with the arrow on the valve body.
- With *steam* and *liquids*, install the spring housing (10) with set point adjuster (8) suspended downwards. With *gases*, the set point adjuster may point upwards or downwards, if not specified otherwise.
- For *toxic* or *flammable media*, the spring housing must be fitted with a venting bore (9) and an adjusting screw seal (12). The venting bore $G \frac{1}{8}$ (9) must be connected to a leakage line for a safe discharge of any medium that may escape.
- The max. perm. downstream pressure p_2 must not exceed the max. adjustable set point by more than 1.5 times.
- The distance between the pressure tapping point of the control line and the regulator must be min. $10 \times DN$.
- For applications with steam ($K_{VS} 5$ to 22/set points 0.02 to 12 bar), the control line must be equipped with an equalizing tank filled with water for downstream pressures up to 1.1 bar.

For applications with steam ($K_{VS} 0.2$ to 1.5 /set points 0.005 to 12 bar) without an equalizing tank, the chamber above the diaphragm must be filled with water through the control line connection (refer to EB 2530 EN).

1 Valve inlet	8 Set point adjuster
1.1 Valve outlet	9 Venting bore $G \frac{1}{8}$
2 Valve plug	(leakage line connection)
3 Valve seat	10 Spring housing
4 Plug stem	11 Control line connection $G \frac{1}{4}$
5 Balancing bushing	12 Adjusting screw seal
6 Operating diaphragm	13 Intermediate piece for steam
7 Positioning spring	(only versions $K_{VS} 0.2$ to 1.5)

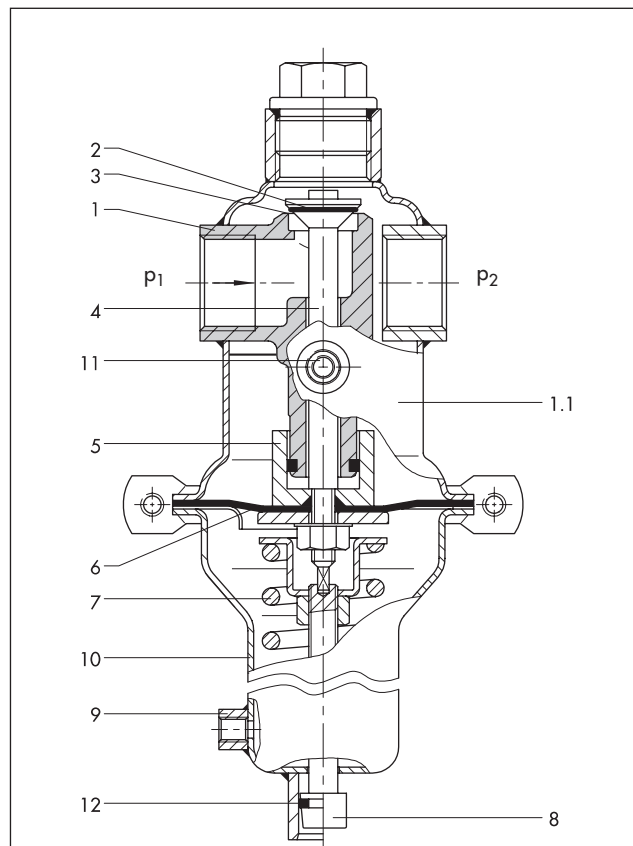

Fig. 3 · Type M 44-2 Pressure Reducing Valve ($K_{VS} 5$ to 22)

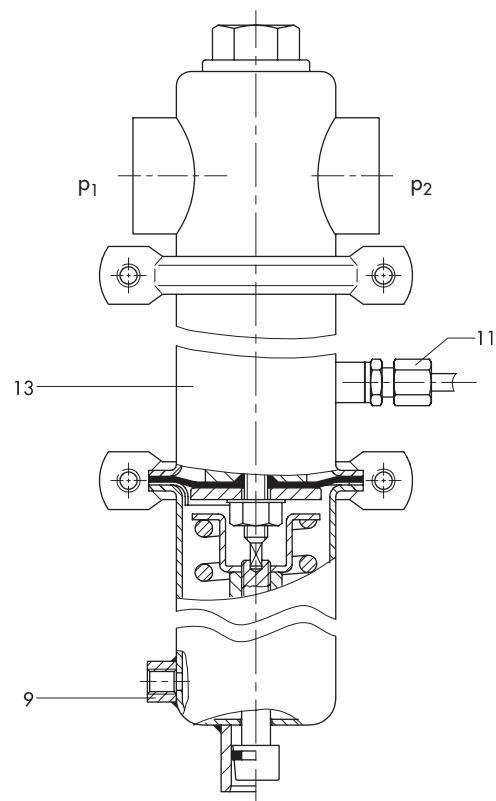



Fig. 4 · Type M 44-2 Pressure Reducing Valve ($K_{VS} 0.2$ to 1.5) version for steam up to 200 °C

Table 1 · Technical data · All pressures in bar (gauge)

	Connection	Nominal size	DN 15		
		Female thread	G ¼		
	K_{VS} coefficient	0.15			
	Nominal inlet pressure	PN 315			
	Set point ranges in bar	0.3 to 1.5 · 1 to 6 · 5 to 20			
	Leakage rate	< 0.05 % of K_{VS}			
Max. perm. temperature	130 °C				
	Connection	Nominal size	DN 15	DN 25	
		Female thread	G ½		
	K_{VS} coefficient	0.2 · 0.5 · 0.9 · 1.5			
	Nominal inlet pressure	PN 250 ¹⁾ · PN 160 ¹⁾ · PN 40			
	Set point ranges in bar	0.005 to 0.025 · 0.02 to 0.12 · 0.1 to 0.5 · 0.2 to 1.1 · 1 to 5 · 4 to 12 · 10 to 20			
	Leakage rate	< 0.05 % of K_{VS}			
	Max. perm. temperature	Liquids/gases	130 °C		
	Steam	200 °C			

¹⁾ Only in version with connection G ½ for liquids and gases



	Connection	Nominal size	DN 15	DN 25	DN 32	DN 40	DN 50
		Female thread	G ½	G 1	G 1¼	G 1½	G 2
	K_{VS} coefficient	5	8	22			
	Nominal inlet pressure	PN 40 · PN 16					
	Set point ranges in bar	0.02 to 0.12 · 0.1 to 0.5 · 0.3 to 1.1 · 0.8 to 2.5 · 2 to 5 · 4 to 8 · 6 to 12					
	Leakage rate	< 0.05 % of K_{VS}					
	Max. perm. temperature	Liquids/gases	130 °C				
	Steam	190 °C					

Table 2 · Max. permissible upstream pressures in bar · Max. perm. differential pressures for liquids $\Delta p_{max} = 25$ bar

K_{VS} 0.15 · Nominal inlet pressure PN 315

	Set point range in bar	0.3 to 1.5	1 to 6	5 to 20
	Nominal outlet pressure	PN 2.5	PN 10	PN 25
	Max. perm. p_1 in bar	20 × set point		20 × set point (max. PN 315)

K_{VS} 0.2, 0.5, 0.9 and 1.5 · Nominal inlet pressure PN 40, PN 160 or PN 250; outlet pressure PN 1, PN 2.5, PN 10, PN 25 or PN 40

	Set point range in bar	0.005 to 0.025	0.02 to 0.12	0.1 to 0.5	0.2 to 1.1	1 to 5	4 to 12	10 to 20
	Nominal outlet pressure	PN 1		PN 2.5	PN 10	PN 25		
	Max. perm. p_1 in bar	1000 × set point		280 × set point	125 × set point	27 × set point		

K_{VS} 5, 8 and 22 · Nominal inlet pressure PN 16 or PN 40; nominal outlet pressure PN 1, PN 2.5, PN 6, PN 10 or PN 16

	Set point range in bar	0.02 to 0.12 ¹⁾	0.1 to 0.5 ¹⁾	0.2 to 1.1 ¹⁾	0.8 to 2.5 ¹⁾	2 to 5	4 to 8	6 to 12	
	Nominal outlet pressure	PN 1		PN 2.5	PN 6	PN 10	PN 16		
	Connection		Max. perm. upstream pressure p_1 in bar						
	DN	G							
	15	½	80 × set point	40 × set point	30 × set point	20 × set point			
	25	1							
	32	1 ¼	50 × set point	25 × set point	18 × set point	12 × set point			
40	1 ½								
50	2								

¹⁾ In the version for steam with a downstream pressure $p_2 \leq 1.1$ bar, an equalizing tank filled with water must be mounted in the control line (refer to T 2595 EN for accessories for pressure regulators)

Dimensions

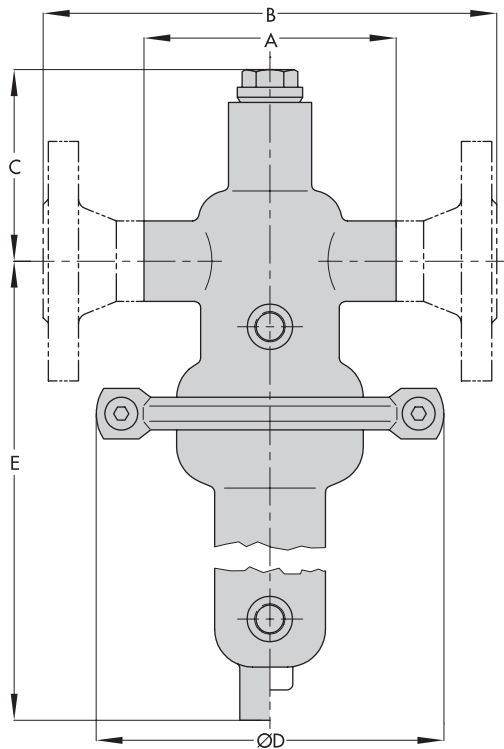

Special version: Welding neck flanges
PN 16/PN 40 acc. to DIN EN 1092-1

Fig. 5 · Version with K_{VS} 5 to 22,
set point ranges 0.02 to 12 bar

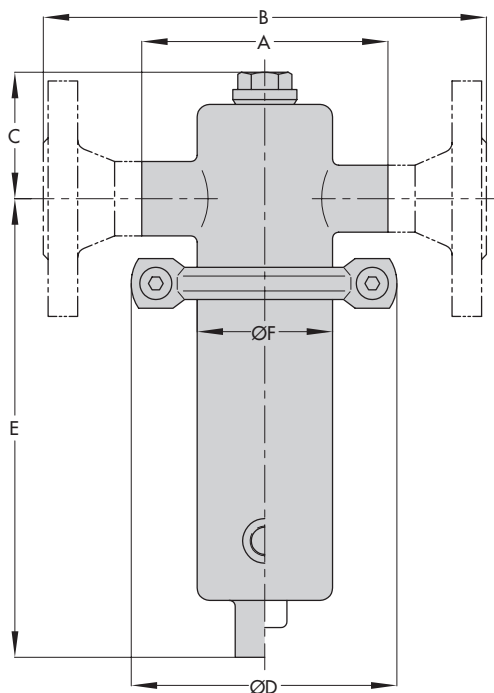

Special version: Welding neck flanges PN 40
acc. to DIN EN 1092-1

Fig. 6 · Version with K_{VS} 0.2 to 1.5;
set point ranges 0.005 to 20 bar

Connection	G	½	1	1 ¼	1 ½	2
	DN	15	25	32	40	50
Set point range in bar	Dimensions in mm · Weights in kg					
All ranges	A	85	85	130	145	185
	B	130	160	180	200	230
	C	76	76	90	90	90
0.02 to 0.12	E	300				
	Ø D	360				
Weight in kg, approx.	G	13.5		14.4		
	DN	15.3		18.4		
0.1 to 0.5	E	300				
	Ø D	264/206				
Weight in kg, approx.	G	7.1		8		
	DN	8.9		12		
0.3 to 1.1	E	300				
	Ø D	200/152				
Weight in kg, approx.	G	6.1		7		
	DN	7.9		11		
0.8 to 5	E	235				
	Ø D	138/110				
Weight in kg, approx.	G	3.1		4		
	DN	4.9		8		
4 to 12	E	235				
	Ø D	138/110				
Weight in kg, approx.	G	3.1		4		
	DN	4.9		8		

A = With threaded connection G ... · B = With welding neck flanges
PN 16 and PN 40 acc. to DIN EN 1092-1 for DN 15 to 50
Ø D = Clamp/diaphragm outer diameter

Connection	G ½	DN 15	DN 25
		Welding neck flanges PN 40	
Set point range in bar	Dimensions in mm · Weights in kg		
All ranges	A	100	-
	C	53	
	Ø F	55	
0.005 to 0.025 0.02 to 0.12	B	-	130 160
	Ø D	360	
	E	255 ¹⁾	
Weight ²⁾ in kg, approx.		6	7.5 8
	B	-	130 160
0.1 to 0.5	Ø D	264/210	
	E	255 ¹⁾	
Weight ²⁾ in kg, approx.		5.5	7 7.5
	B	-	130 160
0.2 to 1.1	Ø D	200/155	
	E	255 ¹⁾	
Weight ²⁾ in kg, approx.		4.5	6 6.5
	B	-	130 160
1 to 5 4 to 12 10 to 20	Ø D	108/80	
	E	185 ¹⁾	
Weight ²⁾ in kg, approx.		1.5	3 3.5

A = With threaded connection G ½ · B = With welding neck flanges
PN 40 acc. to DIN EN 1092-1 · Ø D = Clamp/diaphragm outer
diameter

¹⁾ +130 mm (version for steam) · ²⁾ +1 kg (version for steam)

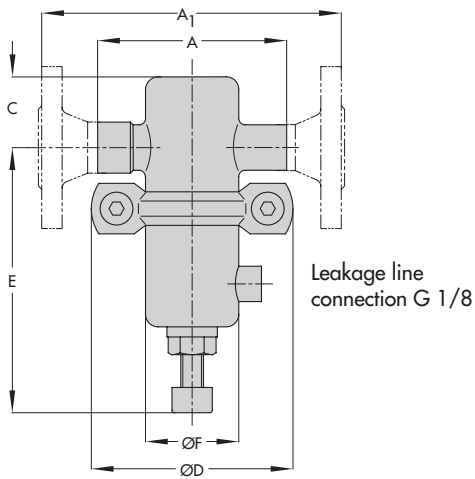

Dimensions in mm

Connection	G ¼ female thread · DN 15
A ₁	130
A	75
C	28
D	80 (55)
E	≈ 105
Ø F	37



Weights

G ¼ female thread	≈ 0.75 kg
DN 15	≈ 2.5 kg

Special version: Welding neck flanges PN 16/PN 40 acc. to DIN EN 1092-1

Fig. 7 · Version K_{VS} 0.15, set point ranges 0.3 to 20 bar

Table 3 · Materials

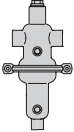
Type			
Set point ranges	0.3 to 20 bar	0.005 to 20 bar	0.02 to 12 bar
Body material	CrNiMo steel		
Plug sealing	Liquids/gases	FPM · EPDM · PTFE	FPM · EPDM · FXM · PTFE
	Steam	–	Metal sealing
Diaphragm	FPM · EPDM		
Protective foil (optional)	PTFE		

Ordering text

Pressure Reducing Valve **Type M 44-2**

Nominal inlet pressure

PN 315/PN 250/PN 160/PN 40/PN 16

Set point range ..., K_{VS} ..., max. perm. temperature ...

Connection G ... or DN with flanges PN 16/PN 40

acc. to DIN EN 1092-1 or

flanges with raised face ANSI Class 150/Class 300

Plug sealing made of EPDM/FPM/FXM/PTFE/metal sealing

Process medium ...

Spring housing standard/with seal and leakage line connection (for toxic, explosive or flammable media)

Special version

External control line, equalizing tank etc.

Specifications subject to change without notice.



SAMSON AG · MESS- UND REGELTECHNIK
Weismüllerstraße 3 · 60314 Frankfurt am Main · Germany
Phone: +49 69 4009-0 · Fax: +49 69 4009-1507
Internet: <http://www.samson.de>

T 2530 EN

2010-08