

# Self-operated Pressure Regulators

## Type 2422/2424 Pressure Reducing Valve



ANSI version

### Application

Pressure regulators for set points from **0.75 to 35 psi** (0.05 to 2.5 bar) · Valves in **NPS 6 to 10**<sup>1)</sup> (DN 150 to 250) Pressure rating **Class 125 to 300** · Suitable for water, gases and vapors up to **660 °F** (350 °C)

The valve **closes** when the downstream pressure **rises**.



The pressure reducing valves, consisting of a valve and an actuator, control the downstream pressure to an adjustable set point. The medium pressure to be kept constant is transmitted through a control line to the diaphragm of the actuator and consequently the valve plug.

### Special features

- Low-maintenance, medium-controlled proportional regulators requiring no auxiliary energy
- Wide set point range and convenient set point adjustment using a nut
- Exchangeable set point springs and actuator
- Spring-loaded, single-seated valve with upstream and downstream pressures balanced by a stainless steel bellows or by a balancing diaphragm
- Standard low-noise plug · Special version with flow divider St I or St III for further noise level reduction (see Data Sheet ▶ T 8081)
- Reduced  $C_v$  ( $K_{vs}$ ) coefficients to adapt the regulator to the operating conditions

### Versions

**Type 2422/2424** · Pressure reducing valve in sizes NPS 6 to 10 (DN 150 to 250), consisting of:

**Type 2422 Valve** with soft-seated plug, balanced by a bellows or a diaphragm · Body of cast iron A126B, cast steel A216 WCC or cast stainless steel A351 CF8M · **Type 2424 Actuator** with EPDM rolling diaphragm

### Special versions

- With flow divider St I or St III for particularly low-noise operation
- Plug with metal seat
- With FPM (FKM) rolling diaphragm, e.g. for mineral oils or flammable gases
- With NBR rolling diaphragm for flammable gases
- Version completely in stainless steel for pressure rating Class 125 to 300. Details on request
- Actuator with two diaphragms
- With metal cover to protect the set point springs

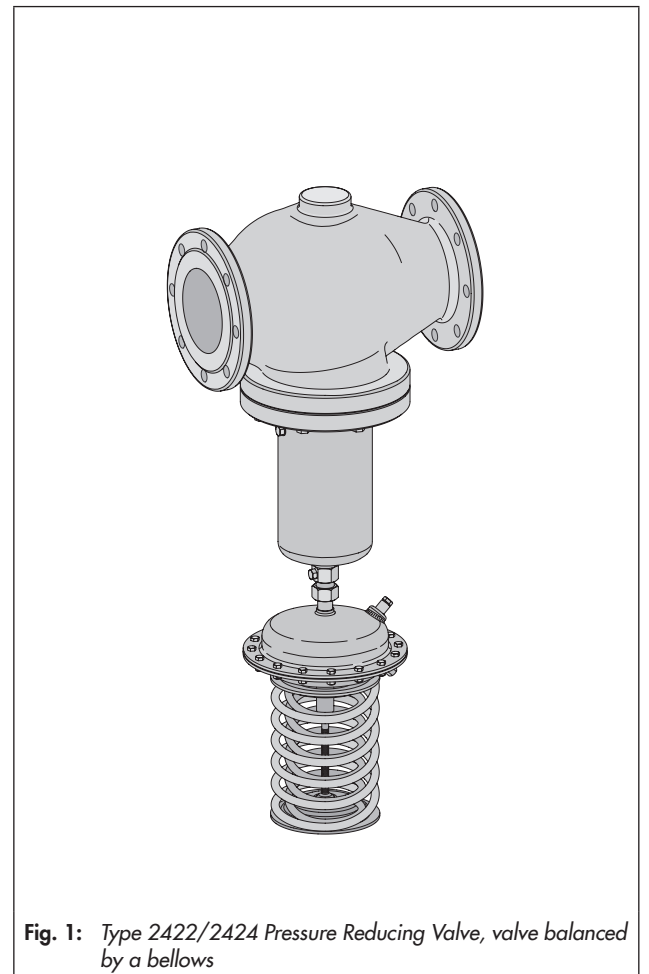

**Fig. 1:** Type 2422/2424 Pressure Reducing Valve, valve balanced by a bellows

<sup>1)</sup> Valves larger than NPS 10 (DN 250) on request

## Principle of operation

The medium flows through the valve in the direction indicated by the arrow. The position of the plug (3) determines the flow rate across the area released between plug (3) and valve seat (2). The plug stem (5) with the plug is connected to the actuator stem (11) of the actuator (10).

The downstream pressure  $p_2$  is regulated by the set point springs (7) and the set point adjuster (6). When relieved of pressure, the valve is opened by the force of the set point springs.

The downstream pressure  $p_2$  to be controlled is tapped downstream of the valve and transmitted over the control line to the operating diaphragm (12) where it is converted into a positioning force. This force is used to move the valve plug (3) according to the force of the set point springs. The spring force is adjustable at the set point adjuster (6). When the force resulting from the downstream pressure  $p_2$  rises above the adjusted pressure set point, the valve closes proportionally to the change in pressure.

The principle of operation of the regulator balanced by a bellows or diaphragm only differs concerning the pressure balancing. The valves balanced by a diaphragm have a balancing diaphragm (4.2) instead of a bellows (4.1). In both cases, the forces created by the upstream and downstream pressures that act on the valve plug are balanced out.

The valves can be supplied with flow divider St I or St III. The valve seat must be replaced on retrofitting the flow divider.

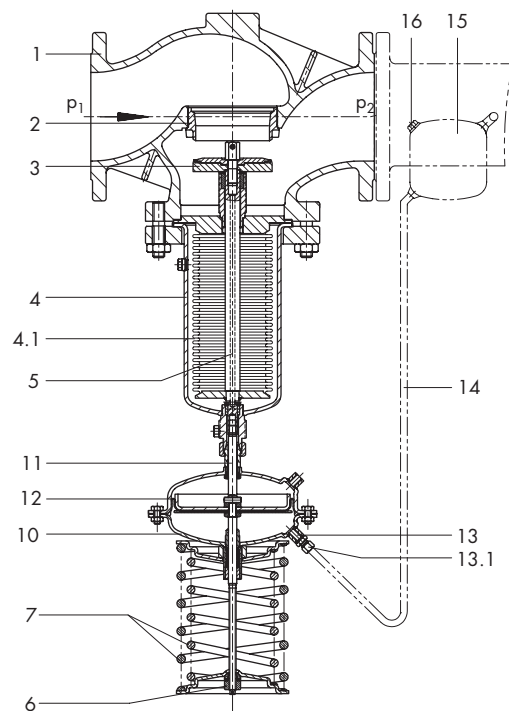

Functional diagram of Type 2422/2424  
Type 2422 Valve balanced by a bellows

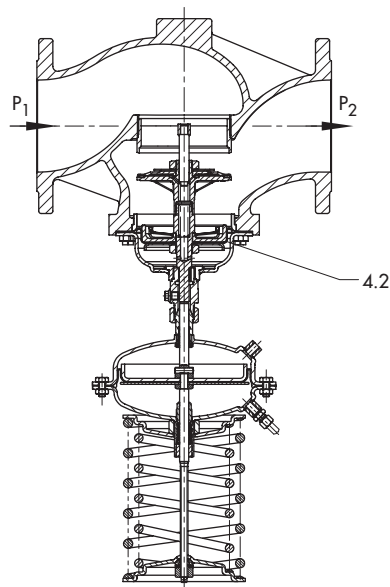

Functional diagram of Type 2422/2424  
Type 2422 Valve balanced by a diaphragm

- |      |  |
|------|--|
| 1    | Valve body   |
| 2    | Seat (exchangeable)                                  |
| 3    | Plug   |
| 4    | Bellows housing                                      |
| 4.1  | Balancing bellows                                    |
| 4.2  | Balancing diaphragm                                  |
| 5    | Plug stem  |
| 6    | Set point adjuster                                   |
| 7    | Set point springs                                    |
| 10   | Actuator   |
| 11   | Actuator stem  |
| 12   | Operating diaphragm                                  |
| 13   | Control line connection G 1/4 (with 1/4 NPT adapter) |
| 13.1 | Screw joint with restriction                         |
| 14   | Control line (to be provided on site)                |
| 15   | Compensation chamber                                 |
| 16   | Filler plug  |
- 
- |       |                     |
|-------|---------------------|
| $p_1$ | Upstream pressure   |
| $p_2$ | Downstream pressure |

**Fig. 2:** Functional diagram of Type 2422/2424 Pressure Reducing Valve

**Table 1: Technical data · All pressures (gauge)**

<b>Type 2422 Valve</b>				
<b>Valve size</b>		<b>NPS 6 · DN 150</b>	<b>NPS 8 · DN 200</b>	<b>NPS 10 · DN 250</b>
Pressure rating		Class 125, 150 or 300		
Max. permissible temperature	Valve body	See pressure-temperature diagram in ► T 2500		
	Plug balanced by a bellows	Metal seal: 660 °F (350 °C) · PTFE soft seal: 430 °F (220 °C) · EPDM or FPM (FKM) soft seal: 300 °F (150 °C) · NBR soft seal: 175 °F (80 °C)		
	Plug balanced by a diaphragm	300 °F (150 °C)		
Leakage class according to IEC 60534-4 or ANSI/FCI 70-2		≤ 0.05 % of C <sub>v</sub> or K <sub>vS</sub> coefficient		
<b>Type 2424 Actuator</b>				
Set point ranges		0.75 to 3.5 psi · 1.5 to 8.5 psi · 3 to 14.5 psi · 7 to 20 psi · 14.5 to 35 psi <sup>1)</sup>		
		0.05 to 0.25 bar · 0.1 to 0.6 bar · 0.2 to 1 bar · 0.5 to 1.5 bar · 1 to 2.5 bar <sup>1)</sup>		
Max. perm. pressure at actuator	Actuator area	50 in <sup>2</sup> · 320 cm <sup>2</sup>		100 in <sup>2</sup> · 640 cm <sup>2</sup>
	Pressure	43.5 psi · 3 bar		22 psi · 1.5 bar
Max. permissible temperature		Gases 350 °C, however, max. 175 °F (80 °C) at the actuator · Liquids 300 °F (150 °C), with compensation chamber max. 660 °F (350 °C) · Steam with compensation chamber max. 660 °F (350 °C)		

<sup>1)</sup> Set point ranges above 35 psi (2.5 bar), see ► T 2554 (Type 2333 Pressure Reducing Valve)

**Table 2: Materials · Material numbers according to ASTM and DIN EN**

<b>Type 2422 Valve, balanced by a bellows</b>				
<b>Pressure rating</b>		<b>Class 125</b>	<b>Class 150/300</b>	
Body		Cast iron A126B	Cast steel A216 WCC	Cast stainless steel A351 CF8M
Seat		1.4006		1.4404
Plug		1.4404		1.4404 with PTFE seal
	Seal for soft-seated plug	PTFE · EPDM · FPM (FKM) · NBR		
Plug stem		1.4301		
Balancing bellows		1.4571		
Bottom section		1.0305		1.4571
Gasket		Graphite on metal core		
<b>Type 2422 Valve, balanced by a diaphragm</b>				
<b>Pressure rating</b>		<b>Class 125</b>	<b>Class 150/300</b>	
Body		Cast iron A126B	Cast steel A216 WCC	Cast stainless steel A351 CF8M
Seat		Red brass <sup>1)</sup>		
Plug (standard version)		Red brass <sup>1)</sup> · With EPDM soft seal or with PTFE soft seal		
Pressure balancing		Balancing cases made of sheet steel DD11 · EPDM balancing diaphragm for liquids and non-flammable gases or NBR diaphragm for flammable gases		
Gasket		Graphite on metal core		
<b>Type 2424 Actuator</b>				
Diaphragm cases		Sheet steel DD11		1.4301
Diaphragm		EPDM with fabric reinforcement · FPM (FKM) · NBR		
Guide bushing		DU bushing		PTFE
Seals		EPDM · FPM (FKM) · NBR		

<sup>1)</sup> Special version: 1.4409

Dimensions · Valve balanced by a bellows

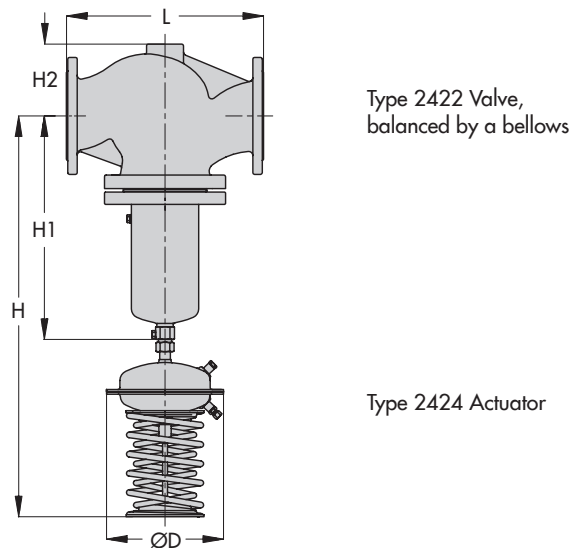

Fig. 3: Dimension diagram · Type 2422/2424 Pressure Reducing Valve, balanced by a bellows

Table 3: Dimensions and weights · Type 2422/2424, valve balanced by a bellows · The values in parentheses apply to temperatures from 430 °F (220 °C) to 660 °F (350 °C)

Valve size		NPS 6 · DN 150	NPS 8 · DN 200	NPS 10 · DN 250
Valve	Length L	Class 125/150	17.75" · 451 mm	21.4" · 543 mm
		Class 300	18.6" · 473 mm	22.4" · 568 mm
	Height H1	23.2" · 590 mm (28.4" · 730 mm)	28.7" · 730 mm (34.25" · 870 mm)	
	Height H2, approx.	6.9" · 175 mm	10.7" · 270 mm	
<b>Set points</b>		<b>Valve with actuator</b>		
0.75 to 3.5 psi 0.05 to 0.25 bar	Height H	44.1" · 1120 mm (49.6" · 1260 mm)	49.6" · 1260 mm (55.1" · 1400 mm)	
	Actuator	ØD = 15.4" · 390 mm, A = 100 in <sup>2</sup> · 640 cm <sup>2</sup>		
1.5 to 8.5 psi 0.1 to 0.6 bar	Height H	44.1" · 1120 mm (49.6" · 1260 mm)	49.6" · 1260 mm (55.1" · 1400 mm)	
	Actuator	ØD = 15.4" · 390 mm, A = 100 in <sup>2</sup> · 640 cm <sup>2</sup>		
3 to 14.5 psi 0.2 to 1.0 bar	Height H	44.1" · 1120 mm (49.6" · 1260 mm)	49.6" · 1260 mm (55.1" · 1400 mm)	
	Actuator	ØD = 15.4" · 390 mm, A = 100 in <sup>2</sup> · 640 cm <sup>2</sup>		
7 to 20 psi 0.5 to 1.5 bar	Height H	40.9" · 1040 mm (46.4" · 1180 mm)	46.4" · 1180 mm (51.9" · 1320 mm)	
	Actuator	ØD = 11.2" · 285 mm, A = 50 in <sup>2</sup> · 320 cm <sup>2</sup>		
14.5 to 35 psi 1 to 2.5 bar	Height H	40.9" · 1040 mm (46.4" · 1180 mm)	46.4" · 1180 mm (51.9" · 1320 mm)	
	Actuator	ØD = 11.2" · 285 mm, A = 50 in <sup>2</sup> · 320 cm <sup>2</sup>		
Weight <sup>1)</sup>		311 lb · 141 kg	619 lb · 281 kg	740 lb · 336 kg

<sup>1)</sup> Valve in Class 125 with actuator. Class 150: +10 %, Class 300: +15 %

**Dimensions · Valve balanced by a diaphragm**

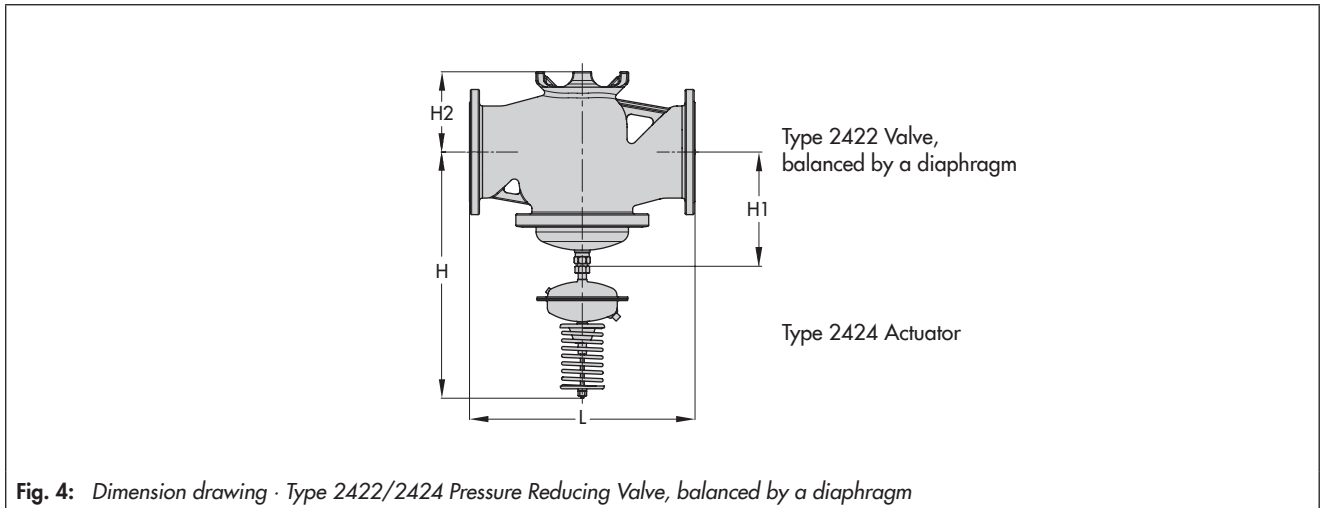

**Fig. 4:** Dimension drawing · Type 2422/2424 Pressure Reducing Valve, balanced by a diaphragm

**Table 4:** Dimensions and weights for Type 2422/2424 · **Balanced by a diaphragm**

Nominal size DN		NPS 6 · DN 150	NPS 8 · DN 200	NPS 10 · DN 250
Valve	Class 125/150	17.75" · 451 mm	21.4" · 543 mm	26.5" · 673 mm
	Class 300	18.6" · 473 mm	22.4" · 568 mm	27.9" · 708 mm
	Height H1	12.2" · 310 mm	15" · 380 mm	
	Height H2, approx.	6.9" · 175 mm	10.7" · 270 mm	
<b>Set points Valve with actuator</b>				
0.75 to 3.5 psi 0.05 to 0.25 bar	Height H	840 mm	910 mm	
	Actuator	ØD = 15.4" · 390 mm, A = 100 in <sup>2</sup> · 640 cm <sup>2</sup>		
1.5 to 8.5 psi 0.1 to 0.6 bar	Height H	33.1" · 840 mm	35.9" · 910 mm	
	Actuator	ØD = 15.4" · 390 mm, A = 100 in <sup>2</sup> · 640 cm <sup>2</sup>		
3 to 14.5 psi 0.2 to 1 bar	Height H	30" · 760 mm	32.7" · 830 mm	
	Actuator	ØD = 11.2" · 285 mm, A = 50 in <sup>2</sup> · 320 cm <sup>2</sup> <sup>1)</sup>		
7 to 20 psi 0.5 to 1.5 bar	Height H	30" · 760 mm	32.7" · 830 mm	
	Actuator	ØD = 11.2" · 285 mm, A = 50 in <sup>2</sup> · 320 cm <sup>2</sup> <sup>1)</sup>		
14.5 to 35 psi 1 to 2.5 bar	Height H	30" · 760 mm	32.7" · 830 mm	
	Actuator	ØD = 8.9" · 225 mm · A = 50 in <sup>2</sup> · 320 cm <sup>2</sup>		
Weight <sup>2)</sup> , approx.		220 lb · 100 kg	534 lb · 243 kg	580 lb · 263 kg

<sup>1)</sup> Optionally with actuator 100 in<sup>2</sup> (640 cm<sup>2</sup>)

<sup>1)</sup> Valve in Class 125 with actuator. Class 150: +10 %, Class 300: +15 %

**Table 5:**  $C_V$  ( $K_{VS}$ ) coefficients and max. permissible differential pressures  $\Delta p_{max}$

Type 2422 Valve, balanced by a bellows							
$C_V$ ( $K_{VS}$ ) coefficients and max. permissible differential pressures $\Delta p_{max}$							
		$C_V$ ( $K_{VS}$ ) coefficients · Differential pressures			Reduced $C_V$ ( $K_{VS}$ ) coefficients · Differential pressures		
Valve size		NPS 6 · DN 150	NPS 8 · DN 200	NPS 10 · DN 250	NPS 6 · DN 150	NPS 8 · DN 200	NPS 10 · DN 250
Standard $C_V$ ( $K_{VS}$ ) coefficients	$C_V$	330	490	585	145	330	330
	$K_{VS}$	280	420	500	125	280	280
Flow divider St I	$C_{VI}$	245	370	440	110	245	245
	$K_{VSI}$	210	315	375	95	210	210
Flow divider St III	$C_{VIII}$	165	230	260	70	165	165
	$K_{VSIII}$	140	200	220	60	140	140
Max. perm. differential pressure $\Delta p_{max}$	psi	175	145	145	230	175	175
	bar	12	10	10	16	12	12

Type 2422 Valve, balanced by a diaphragm				
$C_V$ ( $K_{VS}$ ) coefficients and max. permissible differential pressures $\Delta p_{max}$				
Valve size		NPS 6 · DN 150	NPS 8 · DN 200	NPS 10 · DN 250
$C_V/K_{VS}$ coefficients	$C_V$ coefficient	445	760	930
	$K_{VS}$ coefficient	380	650	800
Max. perm. differential pressure $\Delta p_{max}$	ANSI	175 psi	145 psi	
	DIN	12 bar	10 bar	

### Installation

- Install valves (balanced by a bellows or diaphragm) with the actuator suspended downward.
- Install pipelines horizontally with a slight downward slope on both sides of the valve to prevent condensed water from collecting.
- The direction of flow must match the direction indicated by the arrow on the body.
- Connect a control line to the actuator from the point of pressure tapping located approx. 39" (1 m) downstream of the valve in the pipe wall or at the point of measurement of the connected plant (with compensation chamber, if necessary).



### Ordering text

**Type 2422/2424** Pressure Reducing Valve  
 Valve balanced by a bellows or diaphragm  
 NPS (DN) ..., body material ..., Class ...  
 $C_V$  ( $K_{VS}$ ) coefficient ..., set point range ... psi (bar)  
 Special version ...  
 Accessories ...

### Accessories

- Screw joints with restriction for connection of the control line e.g. for 1/4" or 1/2" (6 or 12 mm) pipe. The control line must be provided on site.
- Only applicable to valves balanced by a bellows: Compensation chamber for condensation and to protect the operating diaphragm against extreme temperatures. The chamber is required for steam and liquids above 300 °F (150 °C).

For detailed information on accessories refer to Data Sheet

► T 2595.

Specifications subject to change without notice



SAMSON AG · MESS- UND REGELTECHNIK  
 Weismüllerstraße 3 · 60314 Frankfurt am Main, Germany  
 Phone: +49 69 4009-0 · Fax: +49 69 4009-1507  
 samson@samson.de · www.samson.de

**T 2548 EN**