

Self-operated Regulators Series 42



Differential Pressure Regulator with Type 2421 Valve

Type 42-10 · Type 42-15

Application

Differential pressure regulators for large heating networks and industrial plants.

For differential pressure set points (Δp) from **0.05 to 1.5 bar**
Valves sizes **DN 15 to DN 50** · Nominal pressure **PN 16 to 40**
Suitable for liquids and vapors from **5 °C to 220 °C**, air and other non-flammable gases up to **80 °C**

The valve **opens** when the differential pressure rises.

The regulators control the differential pressure according to the set point adjusted.

Special features

- Low-noise, self-operated P-regulators requiring little maintenance
- Suitable for circuit water, water/glycol mixtures, steam and air as well as other liquids, gases and vapors, provided these do not affect the characteristics of the operating diaphragm
- Valve body optionally available in cast iron, spheroidal graphite iron, cast steel or forged stainless steel

Versions

Differential pressure regulators for installation in a bypass or short-circuit pipes (see Typical application) · Valve unbalanced

Type 42-10 (Fig. 1) · With Type 2421 Valve for DN 15 to DN 25 · Type 2420 Opening Actuator with fixed set point, adjusted to $\Delta p = 0.2, 0.3, 0.4$ or 0.5 bar · Sealed off between actuator and valve

Type 42-15 (Fig. 2) · With Type 2421 Valve for DN 15 to DN 50 · Type 2425 Opening Actuator with adjustable set point
Sealed off between actuator and valve

Special versions

ANSI versions · Actuator with two diaphragms · Actuator with FPM diaphragm for mineral oil (version for other oils on request) · Special K_{VS} (reduced) · Valve entirely made of corrosion-resistant material (minimum grade 1.4301)

Accessories

Refer to the Data Sheet T 3095 EN for any required accessories, e.g. compression-type fittings, needle valves, equalizing tanks and control lines.



Fig. 1 · Type 42-10 Differential Pressure Regulator



Fig. 2 · Type 42-15 Differential Pressure Regulator

Principle of operation (Figs. 5 and 6)

The medium flows through the valve in the direction indicated by the arrow. The position of the valve plug (3) determines the differential pressure across the free area between the plug (3) and the seat (2).

The differential pressure to be controlled is transmitted to the operating diaphragm (12) where it is converted into a positioning force. This force moves the plug (3) according to the force of the set point springs.

In Type 42-15, the set point can be adjusted at the set point adjustment (17).

In Type 42-10, the set point spring (14) in the actuator determines the set point.

The pressure in the valve is separated from the pressure in the actuator in both versions.

Typical application

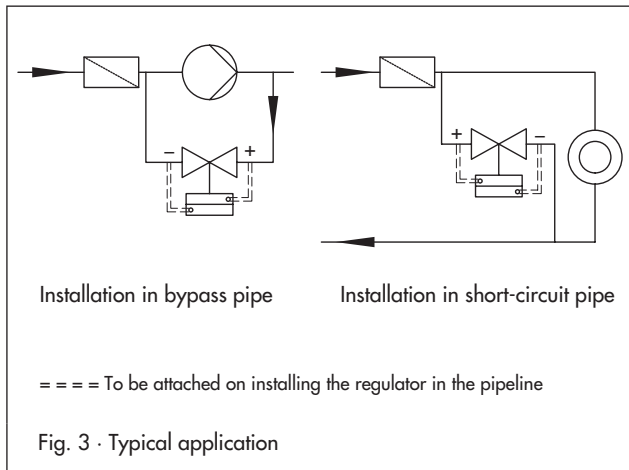

Pressure-temperature diagram – acc. to DIN EN 12516-1 –

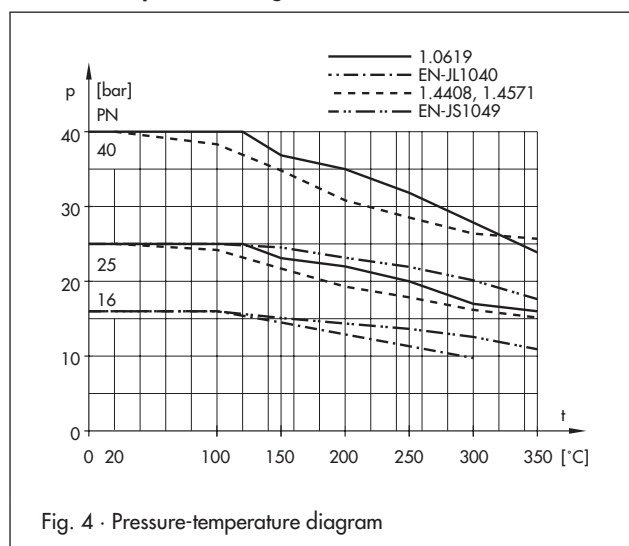

Fig. 4 · Pressure-temperature diagram

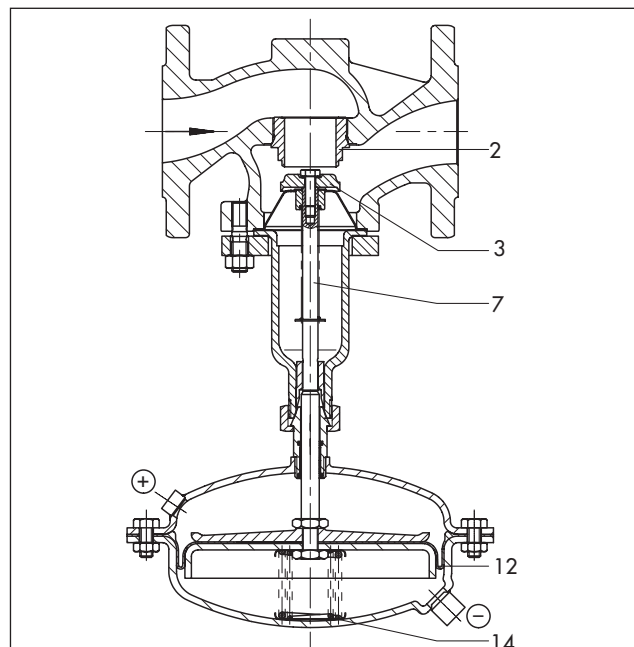

Fig. 5 · Type 42-10 Differential Pressure Regulator

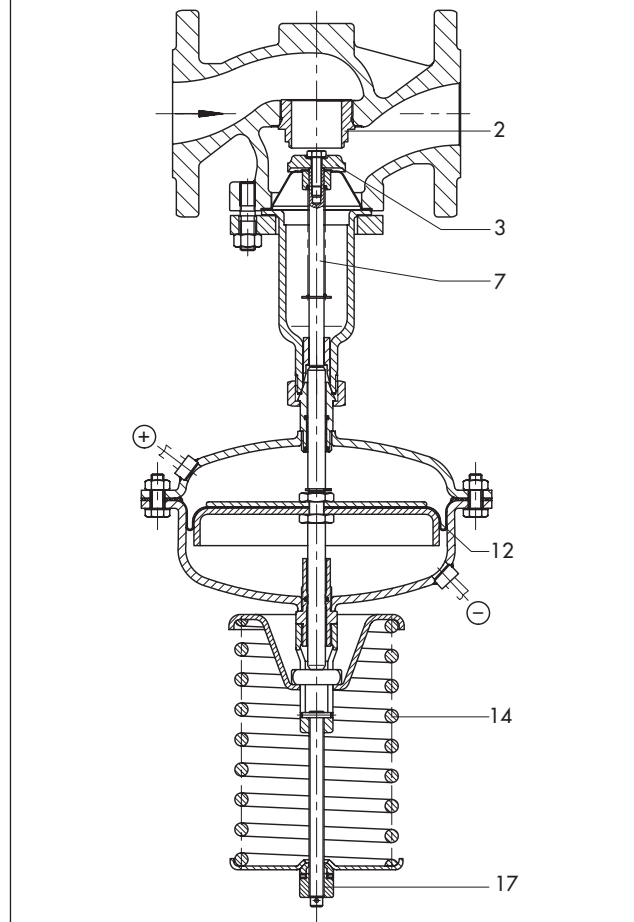

Fig. 6 · Type 42-15 Differential Pressure Regulator

- 2 Seat
- 3 Plug
- 7 Plug stem
- 12 Operating diaphragm
- 14 Set point spring(s)
- 17 Set point adjustment

Table 1 · Technical data

Type		42-10	42-15	
Nominal size		DN 15 to 25	DN 15 to 50	
Nominal pressure		PN 16, 25 or 40 (acc. to to DIN EN 12516-1)		
Max. permissible temperature	Body	See Pressure-temperature diagram		
	Actuator	With equalizing tank: Steam and liquids up to 220 °C Without equalizing tank: Liquids up to 150 °C · Air and gases up to 80 °C		
Diaphragm area of actuator	cm ²	160	160	320
Set point ranges	bar	0.2 · 0.3 · 0.4 · 0.5	0.1 to 0.6 · 0.2 to 1 · 0.5 to 1.5	0.05 to 0.25
Max. permissible operating pressure for actuator with two diaphragms		40 bar	40 bar	25 bar
Leakage rate acc. to IEC 60534-4		≤ 0.05 % of K _{VS}		

Terms for valve sizing according to IEC 60534, Parts 2-1 and 2-2: $F_L = 0.95$; $x_T = 0.75$

Table 2 · Materials · Material number acc. to DIN EN

Type 2421 Valve				
Nominal pressure	PN 16	PN 25	PN 40	
Valve body	Cast iron EN-JL 1040	Spheroidal graphite iron EN-JS 1049	Cast steel 1.0619	Forged stainless steel ¹⁾ 1.4571
Seat and plug	Stainless steel 1.4104			1.4571
Plug stem	Stainless steel 1.4310			
Lower part of body	P265GH			1.4571
Body gasket	Graphite on metal core			
Type 2420 and Type 2425 Actuator				
Diaphragm cases	Sheet steel DD1			1.4301
Diaphragm	EPDM with fabric reinforcement ²⁾			
Guide bushing	DU bushing			PTFE
Seals	EPDM, PTFE ²⁾			

¹⁾ DN 15, 25, 40 and 50 only

²⁾ Special version for mineral oil: FPM (FKM)

Table 3 · Permissible K_{VS} coefficients, z values and maximum permissible differential pressures

Nominal size	DN	15	20	25	32	40	50
Seat diameter ¹⁾	mm	14	19	22	32	32	40
Travel	mm	10					
K _{VS} coefficient ²⁾	Normal	4	6.3	8	16	20	32
	Reduced	0.16 · 0.4 · 1.0 · 2.5 · 4			6.3	8	16
z value ¹⁾		0.65	0.6	0.55		0.45	0.4
Δp in bar ¹⁾	Type 42-10	25	16	14	-		
	Type 42-15				6	4	

¹⁾ For normal K_{VS} coefficient

²⁾ Micro-trim is possible

Installation

The valve and actuator are delivered in separate packaging.

The actuator can be easily mounted before or after the valve is installed using a coupling nut.

The following points need to be observed:

- Install valves in horizontal pipelines
- The medium must flow through the valve in the direction indicated by the arrow on the valve body
- Install a strainer upstream of the valve (e.g. SAMSON Type 2 NI)



Permissible mounting positions

- All nominal sizes: Install the actuator suspended downwards (see photo)
- All nominal sizes and up to 120 °C: Install the actuator upright
- Versions with fixed plug guide: Install the actuator sideways
- Steam applications: Always install actuator suspended downwards

Further details can be found in EB 3005 EN.

Dimensions

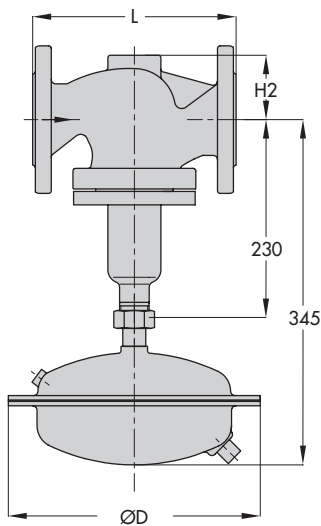

Type 42-10

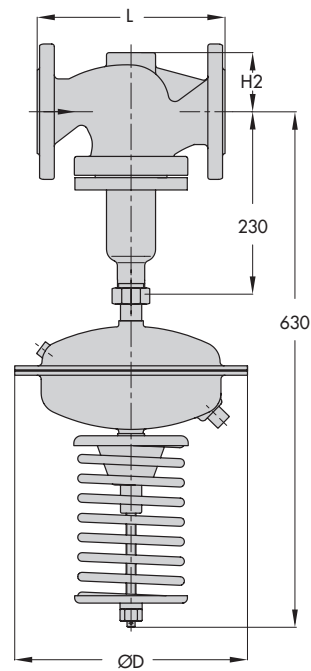

Type 42-15

Dimensions in mm and weights in kg

Nominal size DN	15	20	25	32	40	50	
Length L	130	150	160	180	200	230	
Height H2	Other materials		55		72		
	Forged steel		53	–	70	–	92
Type 42-10 Differential Pressure Regulator							
Set point ranges	0.2 · 0.3 · 0.4 · 0.5 bar						
Actuator size A and diaphragm ØD	A = 160 cm ² ØD = 225 mm			–			
Weight ¹⁾ , approx. in kg	11.5	12	13	–			
Type 42-15 Differential Pressure Regulator							
Set point ranges	0.05 to 0.25 bar						
Actuator size A and diaphragm ØD	A = 320 cm ² · ØD = 285 mm						
Set point ranges	0.1 to 0.6 bar · 0.2 to 1 bar · 0.5 to 1.5 bar						
Actuator size A and diaphragm ØD	A = 160 cm ² ²⁾ · ØD = 225 mm						
Weight ¹⁾ , approx. in kg	16	16.5	17.5	24	24.5	27	

¹⁾ The weight applies to the version with material specifications EN-JL 1040/PN 16. Add 10 % for versions in other materials

²⁾ Optionally with actuator size A = 320 cm²

Fig. 7 · Dimensions of Type 42-10 and Type 42-15

Ordering text

Differential Pressure Regulator **Type 42-10/42-15**

DN ...

Body material ..., PN ...

Set point / set point range ... bar

On option, accessories ... (refer to T 3095 EN)

On option, special version ...

Specifications subject to change without notice.

