

Check Valve (Backflow Prevention) Type 42-10 RS

Application

For safeguarding nitrogen and compressed air networks against backflow from directly connected systems.

Differential pressure set point $\Delta p = 0.2 \text{ bar}$ · Nominal size **DN 15 to DN 150** · Nominal pressure **PN 25/40** · Compressed air and nitrogen up to **80 °C**

The regulator controls the differential pressure to the set point adjusted and prevents backflow from directly connected systems.

The regulator is open, provided the upstream pressure is at least 0.2 bar greater than the downstream pressure. It closes automatically when the downstream pressure rises to or above the value of the upstream pressure.

The regulator closes reliably to prevent backflow from the plant into the compressed air or nitrogen network. The soft-seated plug and seat trim complies with leakage class VI.

Special features

- Low-noise, self-operated P-regulators requiring little maintenance
- If one of the two operating diaphragm ruptures, the undamaged operating diaphragm will take over the function of the damaged diaphragm
- Reliable functioning even in the event of a power failure or when other instruments in the control circuit malfunction
- Diaphragm rupture indication
- Fixed set point
- Regulators delivered ready-to-install without supplementary devices, meaning no additional installations or start-ups are necessary
- Low purchase and installation costs
- Valve body optionally available in cast steel, stainless cast steel or stainless forged steel
- All wetted parts are free of non-ferrous metal
- External adjustment is not possible
- Backflow only leads to a minimum amount of leakage (leakage class VI) due to the soft-seated plug
- An increasing backpressure supports tight shut-off of the valve

Versions

Check valve in supply pipelines

Type 42-10 RS · PN 16 to PN 40 · Type 2421 RS Valve in DN 15 to DN 150 · Type 2420 RS Actuator with two diaphragms · Fixed set point at 0.2 bar · Special version made of stainless steel · Version suitable for steam available on request

On option: Diaphragm rupture indication with pressure switch



Fig. 1 · Type 42-10 RS Check Valve

Principle of operation

The medium flows through the valve in the direction indicated by the arrow. The position of the valve plug (3) determines the differential pressure across the free area between the plug (3) and the seat (2). The valve is closed by the springs in the normal position.

At a differential pressure of 0.2 bar, the valve begins to open; at 0.35 bar the valve is completely open. At this point, the upstream pressure p_1 (compressed air or nitrogen network pressure) must be greater than the downstream pressure p_2 . The valve closes automatically when the downstream pressure rises to or above the value of the upstream pressure.

The valve plug with soft sealing is standard to ensure tight shut-off and to prevent backflow from the plant into the compressed air or nitrogen network.

The mounted control lines (14) transmit the high (+) pressure and low (-) pressure to the actuator.

The actuator with two diaphragms (11) offers increased safety and reliability of functions. The operating diaphragm for high pressure (11.1) is connected to the valve inlet pressure, whereas the operating diaphragm for low pressure (11.2) is connected to the valve outlet pressure. There is a bore with a mechanical diaphragm rupture indication (12) in the intermediate ring located between the two diaphragms. The pressure of response of the diaphragm rupture indication is approximately 1.5 bar. If the diaphragm ruptures, the pressure between the diaphragms will increase and cause the pin of the diaphragm rupture indication to move outward until the red marking appears to indicate the diaphragm rupture. The undamaged operating diaphragm then takes over the function of the damaged operating diaphragm.

A pressure switch (15) can be optionally mounted to the actuator to trigger an alarm (refer to Fig. 3.1)

If a diaphragm rupture is indicated, it is recommended that both diaphragms be replaced.

Installation

The regulator is delivered ready for installation.

On installing the regulator, observe the following instructions:

- Install the valve in a horizontal pipeline free of stress with the actuator suspended downwards.
- Make sure the medium flows through the valve in the direction indicated by the arrow on the valve body.
- Install a strainer upstream of the valve.

Typical application

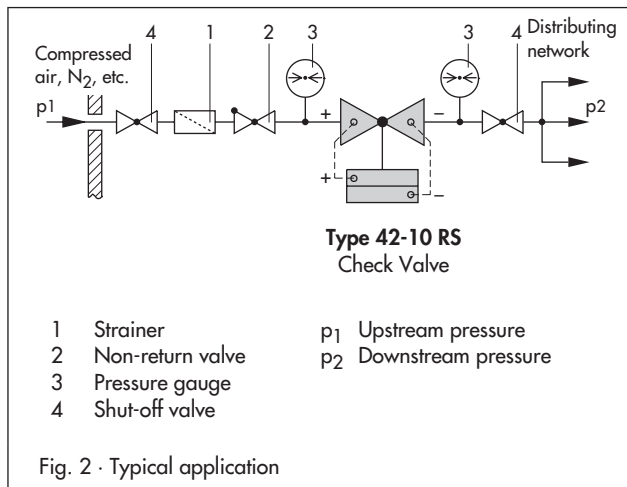

Fig. 2 - Typical application

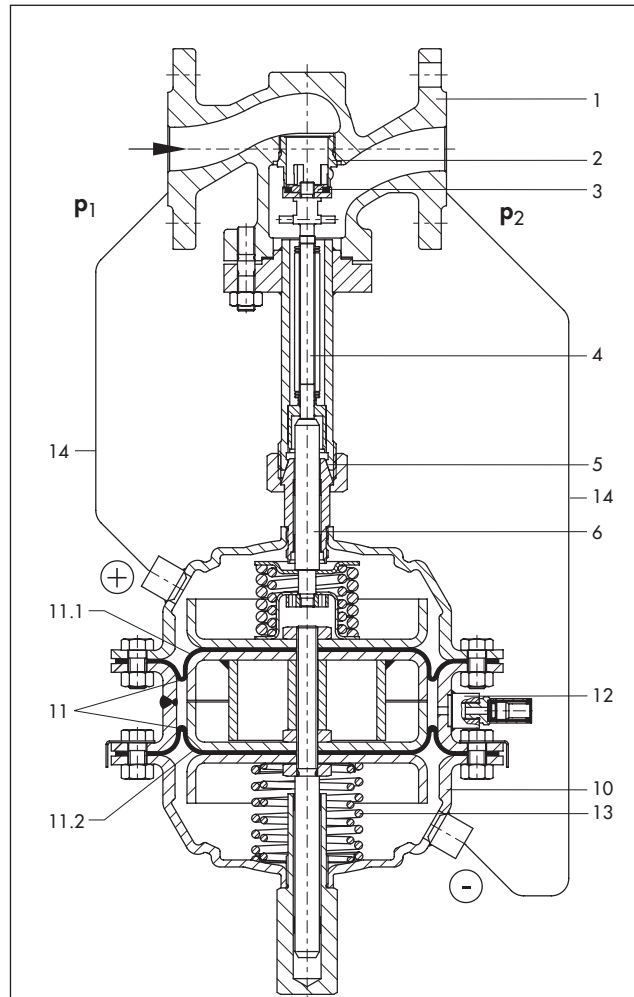

Fig. 3 - Functional diagram



Fig. 3.1 - Actuator with pressure switch (foreground)

- | | |
|------|--|
| 1 | Valve body |
| 2 | Seat |
| 3 | Plug |
| 4 | Plug stem |
| 5 | Threaded connection for diaphragm actuator |
| 6 | Actuator stem |
| 10 | Actuator housing |
| 11 | Two diaphragms |
| 11.1 | Operating diaphragm for high pressure |
| 11.2 | Operating diaphragm for low pressure |
| 12 | Diaphragm rupture indication |
| 13 | Set point spring(s) |
| 14 | Control line 8 x 1 mm |
| 15 | Pressure switch (optional) |

Table 1 · Technical data

Type 2421 RS Valve												
Nominal size	DN	15	20	25	32	40	50	65	80	100	125	150
K _{Vs}		4	6.3	8	16	20	32	50	80	125	190	280
Nominal pressure		PN 25 or 40										
Max. constant operating pressure		25 bar										
Max. permissible temperature		See pressure-temperature diagram (Fig. 4)										
Type 2420 RS Actuator												
Diaphragm area of actuator		320 cm ²					640 cm ²					
Δp set point, fixed		0.2 bar					0.2 bar					
Max. perm. temperature		Air and gases up to 80 °C										

Terms for valve sizing according to DIN EN 60534: F_L = 0.95; x_T = 0.75

Table 2 · Materials · Material number acc. to DIN EN

Type 2421 RS Valve			
Nominal pressure	PN 25/40	PN 25/40	PN 40
Valve body	Cast steel 1.0619	Stainless cast steel 1.4581	Stainless forged steel ¹⁾ 1.4571
Seat and plug	Stainless steel with EPDM soft sealing 1.4404		
Plug stem	Stainless steel 1.4301		
Lower part of body	1.4404/1.4301		
Body gasket	novatec® PREMIUM		
Type 2420 RS Actuator			
Diaphragm cases	Sheet steel DD11	1.4301	
Diaphragm	EPDM with fabric reinforcement		
Guide bushing	DU bushing	PTFE	
Distance piece	Sheet steel DD11	1.4301	
Coupling pin	1.4301		
Seals	EPDM		

¹⁾ DN 15, 25, 40 and 50 only

Pressure-temperature diagram – acc. to DIN EN 12516-1 –

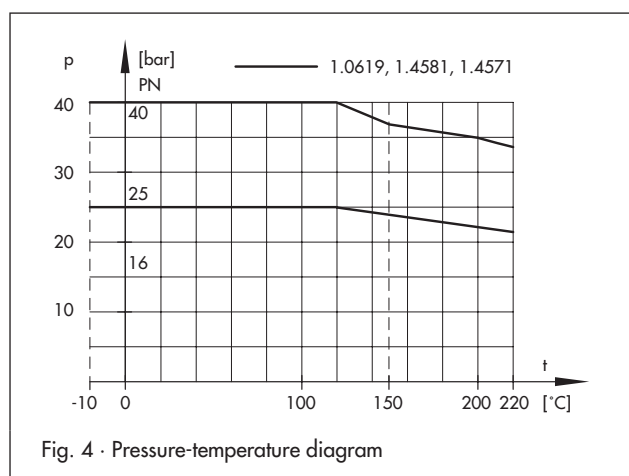
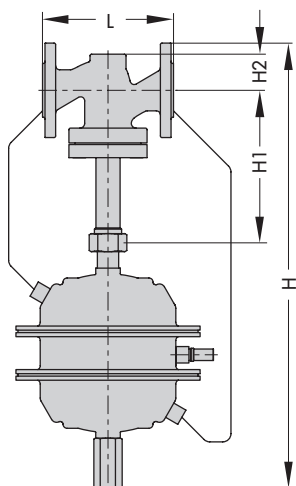

Fig. 4 · Pressure-temperature diagram

Dimensions



Type 42-10 RS

Dimensions in mm and weights in kg

Nominal size DN	15	20	25	32	40	50	65	80	100	125	150
Length L	130	150	160	180	200	230	290	310	350	400	480
Height H1	225						300		355	460	590
Height H2	Other materials		55		72		100		120	145	175
	Forged steel		53	–	70	–	92	98	–	–	–
Height H	550			600			800		830	1000	
Actuator	Ø D = 285 mm · A = 320 cm ²						Ø D = 390 mm · A = 640 cm ²				
Weight in kg	26	26.5	28	35	35.5	39.5	59.5	65.5	75	110	165

Fig. 5 · Dimensions

Ordering text

Check Valve **Type 42-10 RS**

Fixed set point 0.2 bar

DN ...

Body material ..., PN ...

Special version

Specifications subject to change without notice.



SAMSON AG · MESS- UND REGELTECHNIK
 Weismüllerstraße 3 · 60314 Frankfurt am Main · Germany
 Phone: +49 69 4009-0 · Fax: +49 69 4009-1507
 Internet: <http://www.samson.de>

T 3009 EN

2009-05