

Self-operated Regulators Series 42



Combined Self-operated Regulators for Flow Rate with additional electric actuator

Type 42-36 E

Application

Self-operated regulators for flow rate control in district heating systems or large heating networks. Combined with an electric actuator used to transmit the control signal of an electric controller.



Valves in nominal sizes **DN 15 to DN 250** · Nominal pressure **PN 16 to PN 40** · Suitable for liquids from **5 to 150 °C**

The valve closes when the flow rate or the output signal of the electric controller increases. The largest signal closes the valve.

The combined regulators consist of:

- A valve with flanged body
- A diaphragm actuator
- An adapter to adjust the flow rate set point and to attach the electric actuator
- An electric actuator

The electric actuator is available with or without fail-safe action and changes the flow rate set point depending on the output signal issued by the electric controller.

The regulators are equipped with the following electric actuators:

- Valves in nominal sizes **DN 15 to DN 50** · **Type 5824** Electric Actuator without fail-safe action or **Type 5825** with fail-safe action (Fig. 1) · Refer to Data Sheet T 5824 EN.
- Valves in nominal sizes **DN 65 to DN 100** · **Type 3374-11** Electric Actuator without fail-safe action (Fig. 2) or **Type 3374-21** with fail-safe action · Refer to Data Sheet T 8331 EN.
- Valves in nominal sizes **DN 125 to DN 250** · **Type 3374-11** Electric Actuator without fail-safe action or **Type 3374-21** with fail-safe action · Refer to Data Sheet T 8331 EN
Type 3374-15 Electric Actuator without fail-safe action · Refer to Data Sheet T 8331 EN.

Versions

Type 42-36 E (Fig. 1) · Flow Regulator DN 15 to DN 250, consisting of a Type 2426 Diaphragm Actuator and Type 2423 E Valve · With restriction for adjusting the flow rate set point · For installation in flow or return flow pipes.

The set point ranges for the flow rate based on water listed in Table 3 apply to an upper differential pressure of 0.2 or 0.5 bar.

Typetested control equipment according to DIN EN 14597 are available. Register number available on request.



Fig. 1 · Type 42-36 E Flow Regulator with Type 5825 Actuator

Fig. 2 · Type 42-36 E Flow Regulator with Type 3374 Actuator

Special versions

Version for mineral oil · For temperatures up to 220 °C

ANSI version on request.

Table 1 · Selection guide for combined regulators

Regulator		Type 42-36 E			
Basic regulator		Type 42-36			
See Data Sheet		T 3015 EN			
Application for flow rate control \dot{V}					
		Type 42-36 E with Type 5824/25 Electric Actuator	Type 42-36 E with Type 3374 Electric Actuator	Type 42-36 E with Type 3274 Electrohydraulic Actuator or Type 3374 Electric Actuator	
Installation	Flow pipe	•	•	•	
	Return flow pipe	•	•	•	
Set point \dot{V} adjustable		•	•	•	
Electric Actuator					
Nom. size	Type	Fail-safe action			
≤ DN 50	Type 5824	No	•		
	Type 5825	Yes	•		
DN 65 to 100	Type 3374-11	No		•	
	Type 3374-21	Yes		•	
≥ DN 125	Type 3274-11	No		•	
	Type 3274-21	Yes		•	
	Type 3374-15	No			•

Table 1 gives an overview of the different versions of the combined regulators and their typical applications. Refer to Data Sheet T 3015 EN for details on the basic regulator.

Typical applications

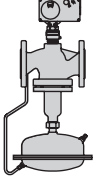
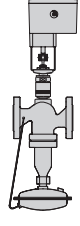
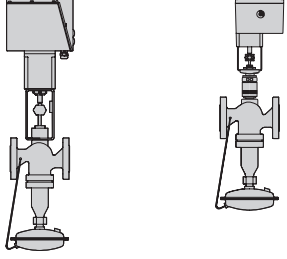
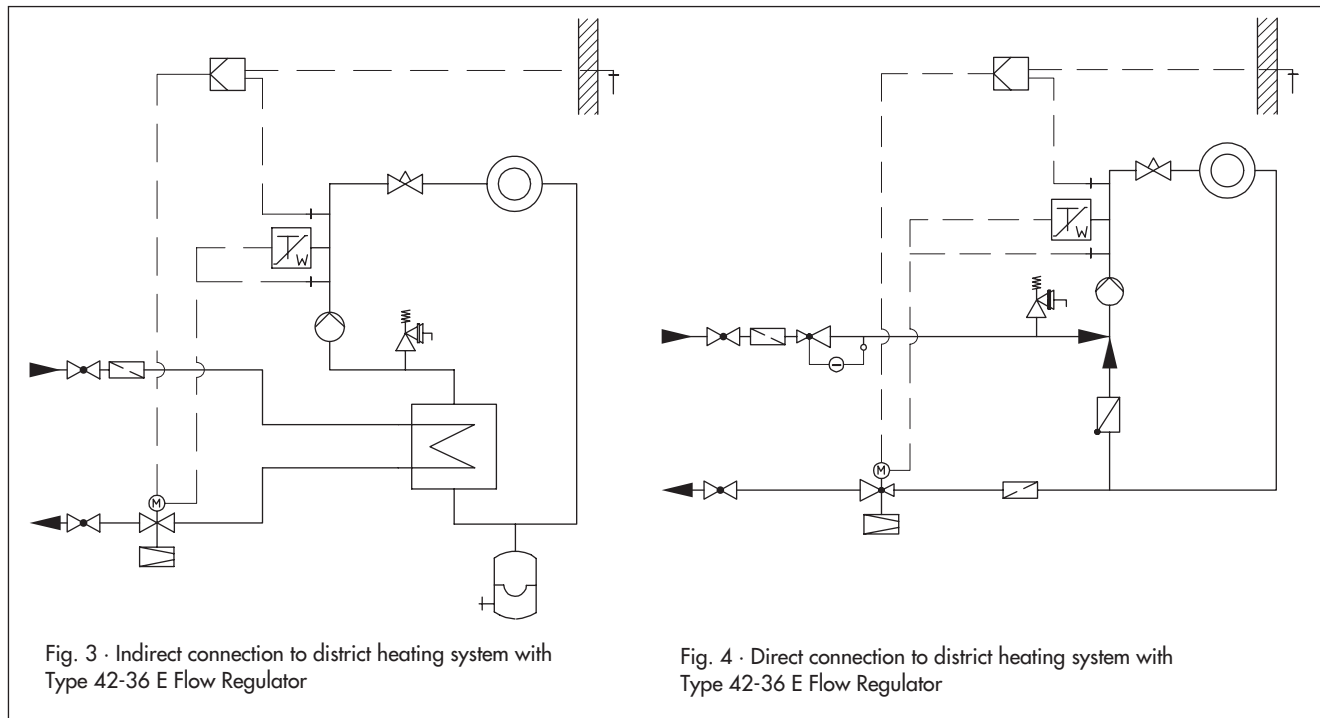

Table 2 · Technical data · Valves · All pressures in bar

Type 2423 E Valve · Balanced by a bellows	
Nominal size	DN 15 to 250
Nominal pressure	PN 16, 25 and 40
Max. medium temperature	150 °C
Max. ambient temperature	50 °C

Type 2423 E Valve · Balanced by a diaphragm	
Nominal size	DN 125 to 250
Nominal pressure	PN 16, 25 and 40
Max. medium temperature	150 °C
Max. ambient temperature	50 °C

Table 3 · K_{VS} coefficients, z values, flow rate set point ranges for water and max. permissible differential pressures

Type 2423 E Valve · Balanced by a bellows																
Nominal size	DN	15	20	25	32	40	50	65	80	100	125	150	200	250		
Travel		10 mm					16 mm			22 mm						
K _{VS} coefficient		4	6.3	8	16	20	32	50	80	125	190	280	420	500		
z value		0.65	0.6	0.55		0.45	0.4		0.35			0.3				
Max. perm. diff. pressure Δp		25 bar					20 bar			16 bar	12 bar	10 bar				
Flow rate set point ranges for water in m ³ /h																
Upper differential pressure at the restriction 0.2 bar		0.5 to 2	0.5 to 3	0.8 to 3.5	2 to 7	3 to 11	3 to 16	5 to 28	7 to 35 ¹⁾	10 to 63	40 to 80	50 to 120	70 to 180	90 to 220		
Upper differential pressure at the restriction 0.5 bar		0.8 to 3	0.8 to 4.5	1.2 to 5.3	3 to 9.5	4.5 to 16	4.5 to 24	7.5 to 40	10 to 55	15 to 90	60 to 120	75 to 180	100 to 260	120 to 300		
Type 2423 E Valve · Balanced by a diaphragm																
Nominal size	DN	125			150			200			250					
K _{VS} coefficient in m ³ /h		250			380			650			800					
z value		0.35					0.3									
Max. perm. diff. pressure Δp		12 bar					10 bar									
Flow rate set point ranges for water in m ³ /h																
Upper differential pressure (at the restriction)		Δp _{restriction} = 0.2 bar			40 to 80			50 to 120			70 to 180			90 to 240		
		Δp _{restriction} = 0.5 bar			60 to 120			75 to 180			100 to 260			120 to 300		

¹⁾ 7 to 35 m³/h with 160 cm² actuator; 7 to 40 m³/h with 320 cm² actuator

Differential pressure across the valve

The minimum required differential pressure Δp_{min} across the valve is calculated as follows:

$$\Delta p_{\min} = \Delta p_{\text{restriction}} + \left(\frac{\dot{V}}{K_{VS}} \right)^2$$

Δp_{min} Minimum differential pressure across the valve in bar

Δp_{restriction} Upper differential pressure created at the restriction (orifice) to measure the flow rate in bar

\dot{V} Flow rate, adjusted in m³/h

K_{VS} Valve flow coefficient in m³/h

Table 4 · Technical data · Actuators

Electric actuators · Type 5824-10, Type 5825-10, Type 5824-20, Type 5825-20, Type 3374-11, Type 3374-21						
Nominal size	DN 15 to 25		DN 32 to 50		DN 65 to 100	
Type ...	5824-10	5825-10	5824-20	5825-20	3374-11	3374-21
Fail-safe action	Without	With	Without	With	Without	With
Rated travel	6 mm		12 mm		15 mm	
Transit time for rated travel	45 s		70 s		120 s	
Transit time for fail-safe action	–	4 s	–	6 s	–	12 s
Positioning force	700 N	–	700 N	–	2500 N	500 N, retracts 2000 N, extends
Nom. closing force of spring	–	500 N	–	500 N		
Power supply	24 or 230 V, 50 Hz				230 V, 50 or 60 Hz ($\pm 10\%$) ¹⁾	
Power consumption	5 VA	7 VA	5 VA	7 VA	max. 18 VA	
Perm. ambient temperature	0 to 50 °C				5 to 60 °C	
Perm. temperature at connecting stem	0 to 130 °C				–	
Details in ...	T 5824 EN				T 8331 EN	

Type 3274-11 and 3274-21 Electrohydraulic Actuators · Type 3374-15 Electric Actuator			
Nominal size	DN 125 to 250		
Type ...	3274-11	3274-21	3374-15
Fail-safe action	Without	With	Without
Rated travel	30 mm		
Transit time for rated travel	120 s		
Transit time for fail-safe action	–	30 s	–
Positioning force	2100 N, stem retracts 2000 N, stem extends		2500 N
Nom. closing force of spring			
Power supply	230 V, 50 or 60 Hz ($\pm 10\%$) ¹⁾		
Power consumption	80 VA		max. 18 VA
Perm. ambient temperature	–35 ²⁾ to 60 °C		5 to 60 °C
Perm. temperature at connecting stem	–		–
Details in ...	T 8340 EN		T 8331 EN

¹⁾ 120 V or 24 V, 50 Hz or 60 Hz on request

²⁾ With heating

Pressure-temperature diagram acc. to DIN EN 12516-1

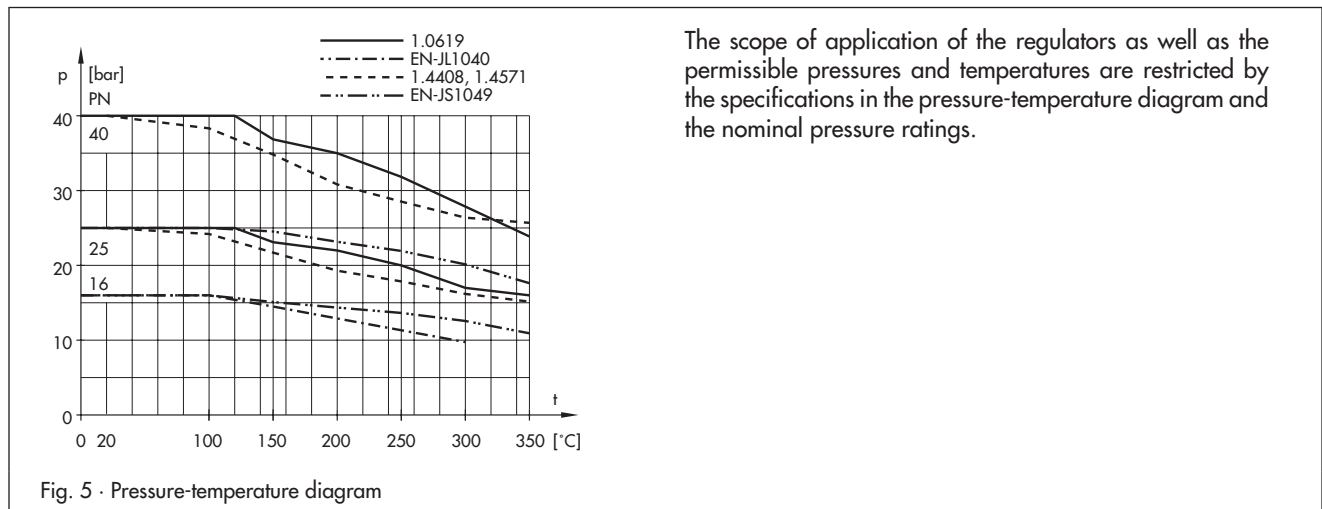

The scope of application of the regulators as well as the permissible pressures and temperatures are restricted by the specifications in the pressure-temperature diagram and the nominal pressure ratings.

Fig. 5 · Pressure-temperature diagram

Table 5 · Materials · Material number according to DIN EN

Type 2423 E Valve · Balanced by a bellows					
Nominal pressure	PN 16	PN 25	PN 16/25/40		
Valve body	Cast iron EN-JL1040	Spheriodal graphite iron EN-JS1049	Cast steel 1.0619	Cast stainless steel 1.4408 ¹⁾	Forged stainless steel 1.4571 ²⁾
Seat	1.4104, 1.4006		1.4571, 1.4404		
Plug	Up to DN 100	1.4104, 1.4006 ³⁾		1.4571, 1.4404	
	DN 125 to 250	1.4301 with PTFE sealing		1.4301, 1.4571 with PTFE sealing	
Plug stem	Stainless steel 1.4301				
Metal bellows	Stainless steel 1.4571 · DN 125 and larger: 1.4404				
Lower section	P265GH			1.4571	
Body gasket	Graphite on metal core				
Type 2423 E Valve · Balanced by a diaphragm					
Nominal pressure	PN 16	PN 25	PN 16/25/40		–
Valve body	Cast iron EN-JL1040	Spheriodal graphite iron EN-JS1049	Cast steel 1.0619	Cast stainless steel 1.4408	–
Seat	Red brass or 1.4409				
Plug (standard version)	Red brass with EPDM soft sealing, max. 150 °C or with PTFE soft sealing, max. 150 °C				
Pressure balancing	Balancing cases made of sheet steel DD11 · EPDM balancing diaphragm, max. 150 °C or NBR diaphragm, max. 80 °C				
Type 2426 Actuator					
Diaphragm cases	Sheet steel DD11		1.4301		
Diaphragm	EPDM with fabric insert (special version for mineral oil: FPM (FKM))				
Guide bushing	DU bushing		PTFE		
Type 5824 · Type 5825 Electric Actuators					
Housing, cover of housing	Plastic (PPO glass fibre reinforced)				
Coupling nut	Brass				
Type 3274 Electrohydraulic Actuator					
Housing, cover of housing	Die-cast aluminum				
Cylinder	Hydraulic cylinder tube				
Piston	Steel-NBR combination				
Piston rod	C 45 hard chrome-plated				
Actuator stem	1.4104				
Hydraulic oil	Special HLP, silicone-free				
Type 3374 Electric Actuator					
Housing and cover	PPO, glass fiber reinforced				
Central attachment and yoke	Flange: aluminum, connecting thread M30 x 1.5 Formed sheet: 1.4301H injected into housing, 30 mm hole				
Actuator stem	1.4305				

¹⁾ DN 65 to 150 only²⁾ DN 15, 25, 40 and 50 only³⁾ Optionally with soft sealing with standard K_{V5} coefficients

Principle of operation (Fig. 6)

The regulators consist of a basic regulator for flow rate control and an electric or electrohydraulic actuator. The principle of operation for the basic regulator is described in the Data Sheet T 3015 EN.

The set point for the flow rate is adjusted at the adapter (9). The adapter is also used to attach the electric actuator. The actuator is operated by control signals (mostly temperature signals) issued by an electric controller. As a result, the electric actuator adjusts the orifice (restriction) and the flow rate as a result.

The actual regulation is performed by the diaphragm actuator. The largest signal is always used to control the regulator.

Additional temperature control

The regulators in sizes DN 150 and smaller (larger nominal sizes on request) can additionally be equipped with a double adapter (see Data Sheet T 3019 EN) and a Type 2231 or Type 2232 Control Thermostat (see Information Sheet T 2010 EN). They also carry out the temperature control or limitation according to the temperature adjusted at the thermostat.

Installation

Choose a place of installation that allows you to freely access the regulator even after the entire plant is completed.

The valve must be installed in horizontal pipelines with the diaphragm actuator suspended downwards. Make sure the process medium flows through the valve in the direction indicated by the arrow on the body.

Valve and actuator are delivered unattached. The electric or electrohydraulic actuator can be easily mounted before or after the valve is installed. A coupling nut is used for attachment.

When insulating the regulator, do not insulate the electric actuator and the coupling nut! Make sure the permissible ambient temperature is not exceeded. If necessary, install an extension piece to protect the actuator. The insulation should not go further than approx. 25 mm above the top of the valve body.

Accessories

Required accessories, such as compression-type fittings, needle valves, equalizing tanks and control lines, are listed in Data Sheet T 3095 EN.

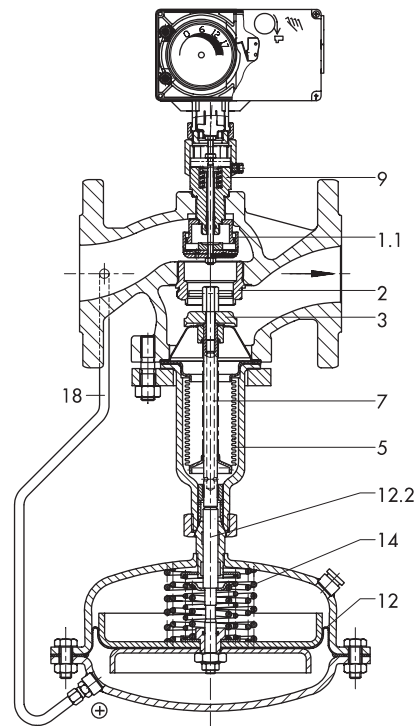

- | | | | |
|-----|---|------|---------------------|
| 1.1 | Restriction for adjusting flow rate set point | 12.2 | Diaphragm stem |
| 2 | Seat | 14 | Set point spring(s) |
| 3 | Plug | 18 | Control line |
| 5 | Balancing bellows | | |
| 7 | Plug stem | | |
| 9 | Adapter | | |
| 12 | Operating diaphragm | | |

Fig. 6 · Type 42-36 E with Type 5825 Electric Actuator

Dimensional drawings · Type 2423 E Valve balanced by a bellows

DN 15 to 50

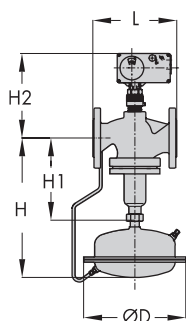
 Type 42-36 E with
Type 5824/5825 Actuator

DN 65 to 100

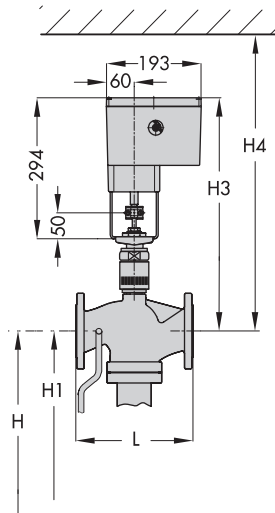
 Type 42-36 E with
Type 3374 Actuator

DN 125 to 250



 Type 42-36 E with
Type 3274/3374 Actuator

Table 6 · Dimensions in mm and weights in kg

Actuator ...		Type 5824 · Type 5825						Type 3374		
Nominal size	DN	15	20	25	32	40	50	65	80	100
Length L		130	150	160	180	200	230	290	310	350
Height H1		225						300		355
Height H2	Other materials	220			240			-		
	Forged steel 1.4571	218	-	240	-	260	266	-		
Height H3		-						520		540
Height H4		-						820		890
Type 42-36 E Flow Regulator										
Height H		390						465		520
Diaphragm actuator		Ø D = 225 mm, A = 160 cm ² ²⁾								
Weight for PN 16 ¹⁾	kg	13.5	14	15	21.5	22	24.5	51	56	71

Actuator ...		Type 3274				Type 3374			
Nominal size	DN	125	150	200	250	125	150	200	250
Length L		400	480	600	730	400	480	600	730
Height H1		460	590	730	730	460	590	730	730
Height H2	Other materials	-							
	Forged steel 1.4571	-							
Height H3		680	710	825	825	510	595	660	690
Height H4		830	860	975	975	860	950	1010	940
Type 42-36 E Flow Regulator									
Height H		625	765	895	895	625	765	895	895
Diaphragm actuator		Ø D = 285 mm, A = 320 cm ² ³⁾							
Weight for PN 16 ¹⁾	kg	135	185	440	500	125	170	425	485

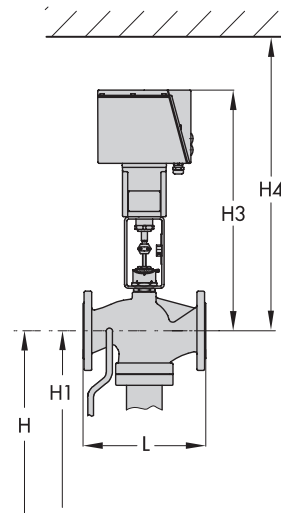
¹⁾ +10 % for steel cast PN 40 and spheroidal graphite iron PN 25. ²⁾ Optionally with actuator 320 cm² for DN 65 to 100. For regulators with double adapter (see T 3019 EN) for DN 65 to 100, actuator 320 cm² recommended. ³⁾ Optionally with actuator A = 640 cm² and Ø D = 390 mm

Fig. 7 · Dimensions of the regulators with a valve balanced by a bellows

Dimensions and weights · Type 42-36 E with Type 2423 E Valve balanced by a diaphragm

Dimensional drawings · Type 2423 E Valve balanced by a diaphragm

Type 42-36 E with Type 3274 Electrohydraulic Actuator

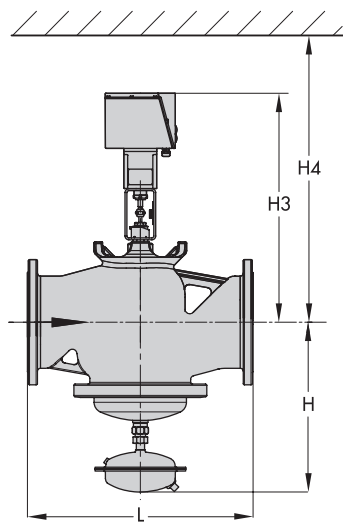

Type 42-36 E with Type 3374 Electric Actuator

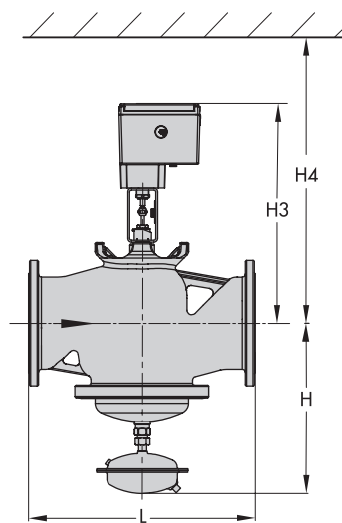

**Table 7 · Dimensions in mm and weights in kg
with Type 3274 Actuator**

Nominal size DN	125	150	200	250
Length L	400	480	600	730
Height H	450	475	545	545
Height H3	680	710	825	825
Height H4	830	860	975	975
Weight ¹⁾ , kg	100	120	300	320

¹⁾ Based on cast iron (EN-JL1040), other materials +10 %

**Table 8 · Dimensions in mm and weights in kg
with Type 3374-15 Actuator**

Nominal size DN	125	150	200	250
Length L	400	480	600	730
Height H	450	475	545	545
Height H3	510	595	660	690
Height H4	860	950	1010	940
Weight ¹⁾ , kg	90	110	290	310

¹⁾ Based on cast iron (EN-JL1040), other materials +10 %

Fig. 8 · Dimensions of the regulators with a valve balanced by a diaphragm

Ordering text

Flow Regulator Type 42-36 E

With valve in DN ..., PN ..., K_{VS} ...

Upper differential pressure at the restriction ... bar,

With Electric Actuator Type ...

Power supply ... V, ... Hz

Optionally with Control Thermostat Type ...,
set point range ... °C

Optionally with accessories, special version

Specifications subject to change without notice.



SAMSON AG · MESS- UND REGELTECHNIK
Weismüllerstraße 3 · 60314 Frankfurt am Main · Germany
Phone: +49 69 4009-0 · Fax: +49 69 4009-15 07
Internet: <http://www.samson.de>

T 3018 EN

2011-08