

Service Unit Type 3999-009X

for conditioning and control of compressed air



General

The reliability and efficiency of a pneumatic instrumentation and control system depends largely on the condition of the supply air. Supply air conditioning to meet the operational requirements is essential for the functional reliability of pneumatic components.

The Type 3999-009X Service Unit is used for the compressed air supply of pneumatic transmitters, controllers and valve positioners. The unit removes dirt, water and oil from the compressed air. At the same time, the air pressure is regulated to a constant output pressure.

The Type 3999-0096 Filter Regulator (see Data Sheet T 3999-8 EN) can be used for the compressed air supply of pneumatic volume boosters for large actuators.

Versions

Service unit with bracket

comprising coarse filter, pressure reducer, pressure gauge and submicro filter,
 condensate drainage over float valves **Order no. 3999-0090**
 condensate drainage over solenoid valves **Order no. 3999-0093**

Service unit on mounting plate

comprising manual spool valve, coarse filter, pressure reducer, pressure gauge, submicro filter and pressure switch,
 condensate drainage over float valves **Order no. 3999-0091**
 condensate drainage over solenoid valves **Order no. 3999-0094**

Service unit on mounting plate

comprising manual spool valve, coarse filter, pressure reducer, pressure gauge, submicro filter, differential pressure switch and pressure switch,
 condensate drainage over float valves **Order no. 3999-0092**
 condensate drainage over solenoid valves **Order no. 3999-0095**

Principle of operation

The compressed air flows across a manual spool valve ① and a coarse filter ② with a maximum input pressure p_1 of 16 bar. The air is cleaned of coarse dirt particles larger than $8\ \mu\text{m}$ as well as water and oil, while the pressure is reduced to a constant output pressure p_2 of 0.5 to 10 bar by a pressure reducer ③. The output pressure p_2 is indicated on a pressure gauge ④ and monitored by a pressure switch ⑦. The prefiltered air flows across a submicro filter ⑤, retaining dirt particles larger than $0.01\ \mu\text{m}$. The function of the submicro filter ⑤ is monitored by a differential pressure switch ⑥.

The coarse filter ② and the submicro filter ⑤ are fitted with either float valves or solenoid valves. The float valves open automatically when a defined liquid level is reached. In the event of failure, the condensate receptacle can be drained manually by unscrewing the drain plug. The solenoid valves must be opened by an external control signal at regular intervals, depending on the degree of contamination of the compressed air.



Fig. 1 · Type 3999-0092 Service Unit

Block diagram

Double-throw contact:

1 = C (lilac)

2 = NC (blue)

4 = NO (red)

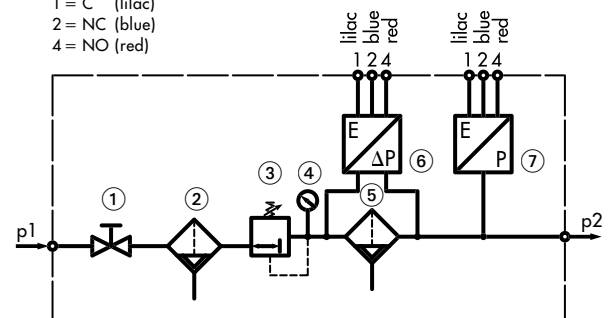

- ① Manual spool valve (Types -0091/-0092/-0094/-0095)
- ② Coarse filter
- ③ Pressure reducer
- ④ Pressure gauge
- ⑤ Submicro filter
- ⑥ Differential pressure switch (Types -0092/-0095)
- ⑦ Pressure switch (Types -0091/-0092/-0094/-0095)

Fig. 2

Technical data

General data		
Attachment	Pipe or wall mounting	
Mounting position	Upright, condensate drainage downwards	
Ambient temperature	+5 ... +50 °C	
Degree of protection	IP 54	
Connection	Input	G 3/8 female (for Types -0090/-0093), G 3/8 male (for Types -0091/-0092/-0094/-0095)
	Output	G 3/8 female (for Types -0090/-0093), Compression fitting for pipe \varnothing 12 mm (for Types -0091/-0092/-0094/-0095)
Weight, approx.	3.6 kg (for Types -0090/-0093), 5.8 kg (for Types -0091/-0094), 6.3 kg (for Types -0092/-0095)	
Bracket (Types -0090/-0093)		
Material	Steel, chromated	
Mounting plate (Types -0091/-0092/-0094/-0095)		
Material	Steel, powder-coated, gray-beige RAL 1019	
Manual spool valve (Types -0091/-0092/-0094/-0095)		
Nominal size	3/8"	
Filter unit		
Version	Coarse filter, submicro filter, pressure reducer with secondary venting, pressure gauge	
Material	Coarse filter cartridge	Sintered bronze
	Submicro filter cartridge	Borosilicate glass
	Condensate receptacle	Makrolon, clear, with cromated steel cage
Medium	Compressed air, free of corrosive particles	
Input pressure p1	Max. 16 bar (max. 8 bar for solenoid valves with 24 V DC)	
Output pressure p2	0.5 ... 10 bar, adjustable	
Flow rate	According to characteristic (see Fig.3)	
Filter mesh	Coarse filter cartridge	8 μ m particle size
	Submicro filter cartridge	0.01 μ m particle size
Receptacle volume	2 \times 65 cm ³ condensate	
Condensate drainage	Automatic over float valves (for Types -0090/-0091/-0092), Automatic over solenoid valves (for Types -0093/-0094/-0095)	
Differential pressure switch (Types -0092/-0095)		
Set point	0.25 bar, set by manufacturer	
Version	Double-throw contact, floating	
Switching capacity	Max. 250 V AC, 5 A	
Connection	Connector according to EN 175301-801, form A	
Pressure switch (Types -0091/-0092/-0094/-0095)		
Set point	0.5 ... 6 bar, adjustable	
Version	Double-throw contact, floating	
Switching capacity	Max. 250 V AC, 5 A	
Connection	Connector according to EN 175301-801, form A	
Solenoid valves (Types -0093/-0094/-0095)		
Rated signal	24 V DC (for p1 = max. 8 bar), AC rated signal (for p1 = max. 16 bar) on request	
Connection	Connector according to EN 175301-801, form A	

Flow rate diagram

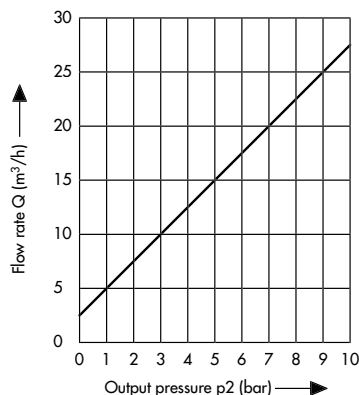
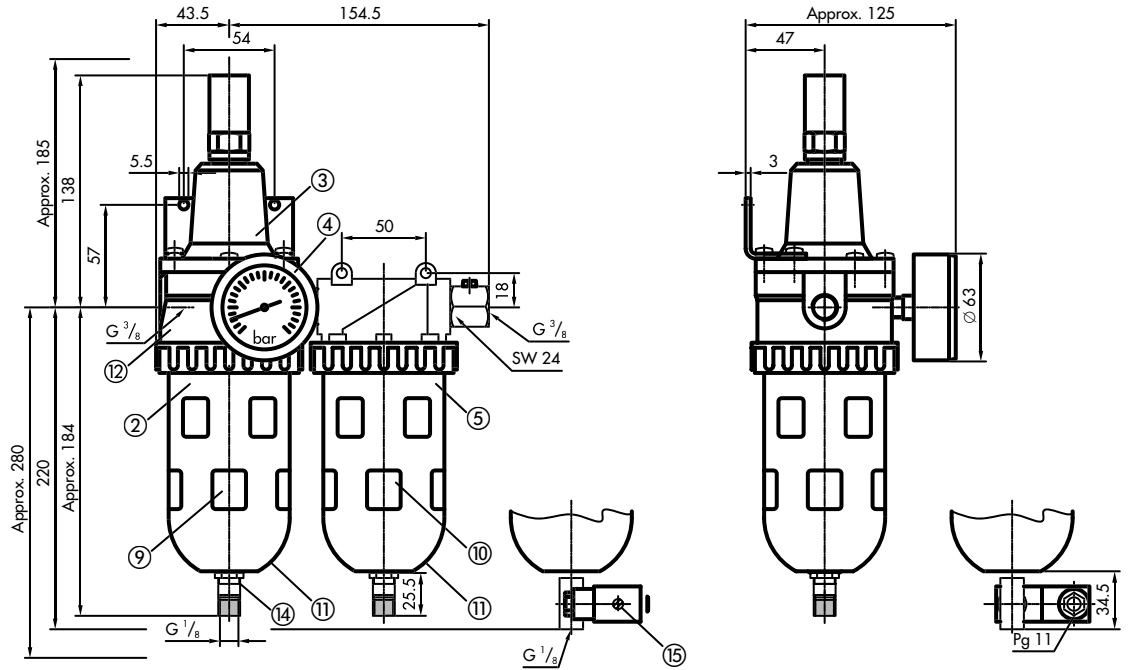
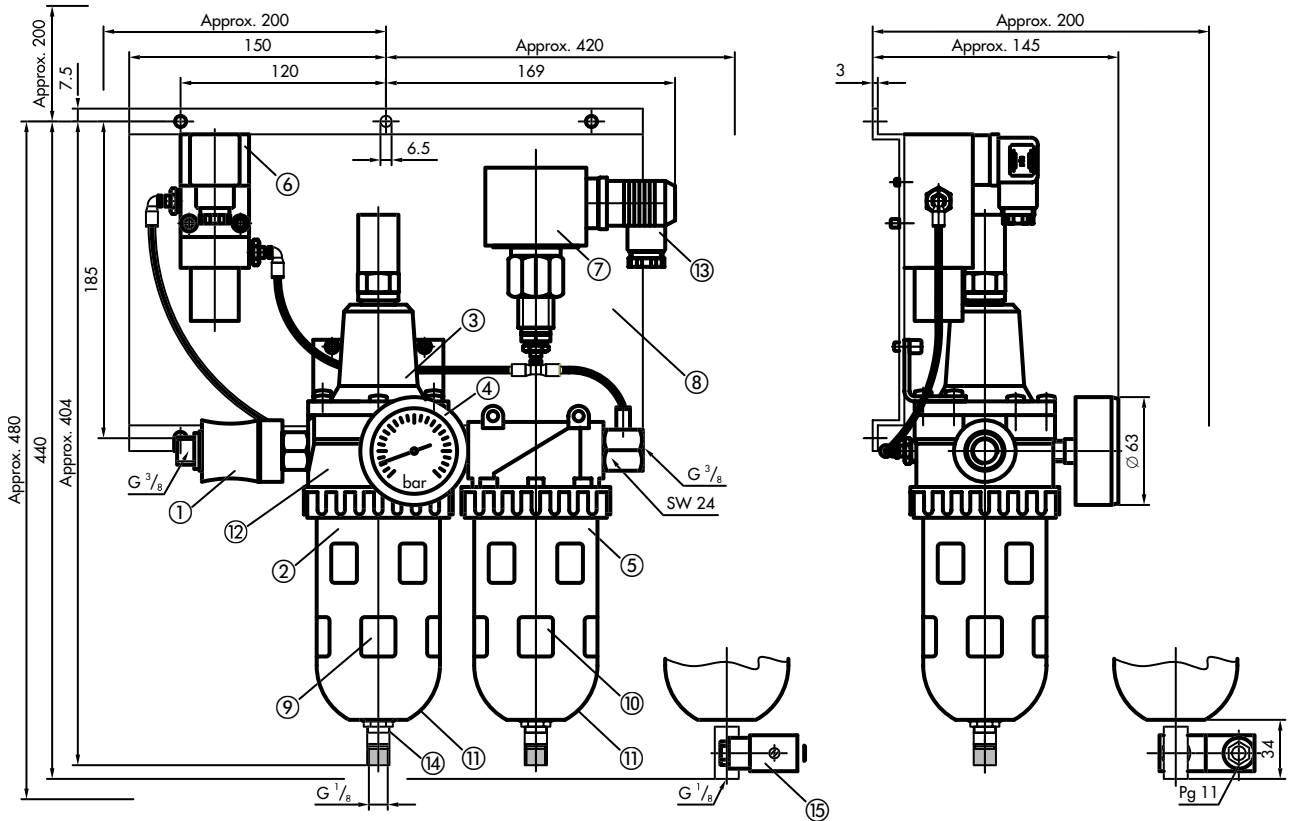

Fig. 3 · Flow rate Q at a differential pressure of 0.5 bar between input pressure p1 and output pressure p2

Dimensions Types 3999-0090/-0093



Dimensions Types 3999-0091/-0092/-0094/-0095



Designation	Order no.
① Manual spool valve G 3/8	0790-6697
② Coarse filter	-
③ Pressure reducer	-
④ Pressure gauge	0790-6967
⑤ Submicro filter	-
⑥ Differential pressure switch	0790-6659
⑦ Pressure switch	3994-9001
⑧ Mounting plate	0790-6683

Designation	Order no.
⑨ Coarse filter cartridge 8 µm	0790-6691
⑩ Submicro filter cartridge 0.01 µm	0790-6692
⑪ Condensate receptacle	0790-6693
⑫ Diaphragm	0790-6694
⑬ Cable socket	0790-6658
according to EN 175301-803, form A	
⑭ Float valve G 1/8	0790-6965
⑮ Solenoid valve G 1/8	0790-6966

Fig. 4 · Dimensions in mm

Installation instructions

Ambient conditions

The service unit may be installed only in rooms with an ambient temperature of +5 to +50 °C. It should be installed preferably in the coolest location in the room so that no water can condense in the output pressure pipe.

Mounting position

The service unit must be installed in the output pressure pipe with the condensate drainage in the upright position facing downwards. It must be installed at the lowest point of the output pressure pipe so that condensate can flow always to the service unit.

Output pressure pipe

The output pressure piping must be adequately sized so that the pressure loss is negligible.

Operation



The maximum permissible input pressure p_1 of 16 bar must not be exceeded!

Adjustment instructions

The following adjustment instructions apply to the versions with pressure switch and differential pressure switch:

Differential pressure switch

The differential pressure switch is adjusted by the manufacturer to a set point of 0.25 bar.



This adjusted set point must not be changed!

Pressure switch

The set point of the pressure switch can be adjusted between 0.5 to 6 bar (see Fig. 5). The set point is adjusted using a screwdriver by turning the stem ①, after unscrewing the threaded pin ②. The set point is indicated on the scale ③. The stem ① must be secured by retightening the threaded pin ②.

Maintenance instructions

The following maintenance must be performed at regular intervals, dependent on the degree of contamination of the compressed air (see Fig. 4):

Filter cartridges

Check coarse filter cartridge ⑨ and submicro filter ⑩ for contamination and replace when heavily contaminated. For the versions with differential pressure switch ⑥, contamination of the submicro filter cartridge ⑩ is monitored continuously and automatically registered as contamination causes the pressure to drop.

Condensate drainage

Check functioning of the automatic drainage of the flow valve ⑭ or the solenoid valves ⑮. In case of failure, the condensate receptacles ⑪ with float valves ⑭ can be drained manually by unscrewing the drain plugs. The condensate receptacles ⑪ must be resealed afterwards by retightening the drain plugs.

(Specifications subject to change without notice.)

Set point adjustment at the pressure switch

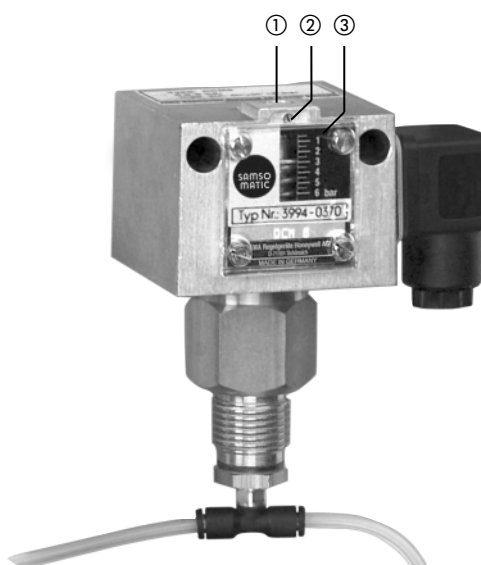

- ① Stem
- ② Threaded pin
- ③ Scale

Fig. 5

SAMSOMATIC GMBH

Weismüllerstraße 20–22
60314 Frankfurt am Main · Germany

Phone: +49 69 4009-0
Fax: +49 69 4009-1644
E-mail: samsomatic@samson.de
Internet: <http://www.samsomatic.de>