

Automation System TROVIS 5400

Ventilation Controller TROVIS 5177



Application

Ranging from simple control of ventilation to cascade control of a temperature and humidity control loop including heating register, energy recovery system, cooling register and humidifier · Communication with other controllers via LON or with a digital process control system via RS-232 interface.



The TROVIS 5177 Ventilation Controller can be used in ten different types of systems (see Table "System functions and applications").

Using the TROVIS 5177 Ventilation Controller, room ventilation systems can optionally be operated in the following modes: Fixed set-point control of the supply air, the exhaust air or the room air. Cascade control of either the exhaust air or the room air is also selectable. In these modes, the heating register can optionally be operated with a heat recovery system, a cooling register, or both a heat recovery system and a cooling register in sequence.

Temperature control of mixed air is possible for systems with a mixing-air chamber.

In addition to temperature control in systems equipped with a heating or cooling register, humidity control is also possible using an additional output for connecting a humidifier.

The configuration and parameterization of one TROVIS 5177 Ventilation Controller can be transferred to other controllers by means of a special memory module.

Special features:

- Analog input 0 to 10 V for air quality sensor
- Two-stage fans with separate time program, control also possible via the air quality, room temperature or humidity
- Variable flow control can be configured
- Return flow temperature of the heating register can be limited to a minimum or, variably, to a maximum.
- Symbols (pictograms) simplifying configuration and parameterization
- Code number protects against unauthorized alteration of data
- Reporting of desired flow temperature via LON
- Transfer of temperature sensor values to other controllers via LON
- Connection of a memory module
- Connection to Modbus is possible
- RS-232 interface for communication via a modem



Fig. 1 · TROVIS 5177 Ventilation Controller

Inputs and outputs

The TROVIS 5177 Ventilation Controller is equipped with 10 inputs which can optionally be configured as sensor inputs or as binary inputs. The required inputs are determined in accordance with the system code number; e.g., three binary inputs for the functions "feedback of ventilator operation", "system on/off" and "frost protection". Pt 100 and PTC or Pt 100 and Pt 1000 sensors can be connected. Three inputs are also suitable for remote adjustment. Inputs not assigned to a certain system code number can, for example, optionally be used to connect temperature sensors which are prompted by a digital process control system. These, however, are not essential for the actual control.

The TROVIS 5177 Ventilation Controller also has four 0 to 10 V inputs which enable, for example, two active temperature/humidity sensors to be connected.

A maximum of four continuous-action 0 to 10 V outputs control the heating register, mixing air chamber, heat recovery system, humidifier or cooling register. The fourth continuous-action output can optionally be used for controlling the speed of the fans and thus to control the flow rate in accordance with the air quality.

Five floating binary outputs are available for operating pumps and fans. A further binary output is intended for fault indication.

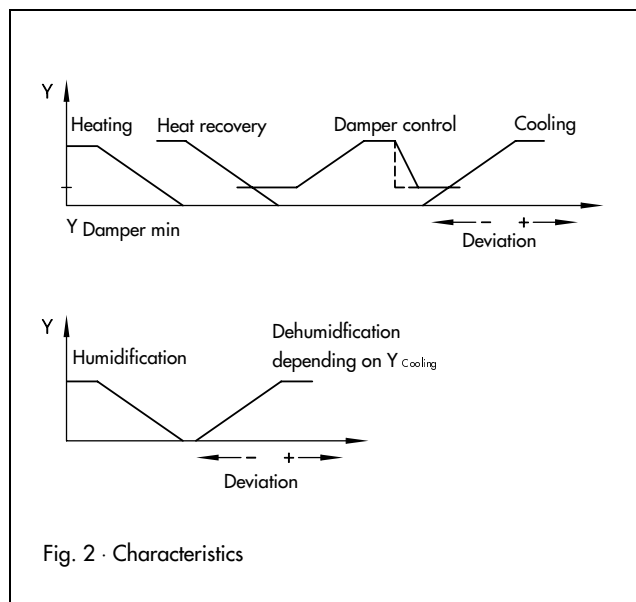

Fig. 2 · Characteristics

For communication with a digital process control system, the ventilation controller offers one RS-232 interface for connecting a modem. It is also possible to connect the device to a specific SAMSON LON network of other SAMSON controllers.

System functions and applications

System code no.	Applications	Special functions
System 0	Ventilation system with one heating register	Outdoor temperature-controlled supply air control, 2-stage fan operation or 0 to 10 V
System 1	Ventilation system with one heating and one cooling register (also chilled ceiling or 1-stage direct evaporator)	Adaptation to summer, Sequence operation heating/cooling or parallel operation, 2-stage fan operation or 0 to 10 V
System 2	Ventilation system with one heating register and one mixing air chamber	Summer mode, Sequence operation heating/damper or mixing air temperature control, Automatic reversal of operating direction for mixing air chamber, 2-stage fan operation or 0 to 10 V
System 3	Ventilation system with one heating register and one heat recovery system	Frost protection for the heat recovery system 2-stage fan operation or 0 to 10 V
System 4	Ventilation system with one heating and one cooling register (also chilled ceiling or 1-stage direct evaporator) and one mixing air chamber	Adaptation to summer, Summer mode, Sequence operation heating/damper/cooling or sequence operation heating/cooling and mixing air temperature control, Automatic reversal of operating direction for mixing air chamber, 2-stage fan operation or 0 to 10 V
System 5	Ventilation system with one heating and one cooling register (also chilled ceiling or 1-stage direct evaporator) and one heat recovery system	Adaptation to summer, Frost protection for the heat recovery system, 2-stage fan operation or 0 to 10 V
System 6	Air-conditioning system with one heating and one cooling register and one humidifier	Configurable for humidifying or humidifying/dehumidifying service, Adaptation to summer 2-stage fan operation or 0 to 10 V
System 7	Air-conditioning system with one cooling register (also chilled ceiling or 1-stage direct evaporator)	Adaptation to summer, 2-stage fan operation or 0 to 10 V
System 8	Air-conditioning system with one heating and one cooling register, one mixing air chamber and one humidifier	Configurable for humidifying or humidifying/dehumidifying service, Adaptation to summer, Summer mode, Automatic reversal of operating direction for mixing air chamber, 2-stage fan operation
System 9	Air-conditioning system with one heating and one cooling register, one heat recovery system and one humidifier	Configurable for humidifying or humidifying/dehumidifying service, Adaptation to summer, 2-stage fan operation

Technical data

Inputs	10 configurable inputs for Pt 100 and PTC sensors, Pt 100 and Pt 1000 sensors or binary messages (e.g. system "on", fan stage 2, feedback on operation of fans and frost protection); 3 inputs F8, F9 and F10 only for 1 to 2 k Ω for potentiometer or binary messages 4 inputs for 0 to 10 V ($R_i = 18 \text{ k}\Omega$) for connecting active temperature, humidity and air quality sensors (temperature measuring range adjustable)
Outputs	
Analog outputs	4 continuous-action outputs 0 to 10 V, load > 5 k Ω
Binary outputs	1 for fault indication, floating, max. 50 V, 100 mA 5 for pumps, fans and refrigerating machines, floating, load: max. 230 V~, 3 A, $\cos \gamma = 0.6$; min. 230 V~, 10 mA/ 24 V~, 50 mA
Interface	RS-232 for modem connection LON (free topology)
Operating voltage	230 V(+10 %, -15 %), 8 VA
Temperature range	Operation: 0 to 40 °C ¹⁾ , Storage -20 to 60 °C
Degree of protection	IP 40 according to IEC 529
Protection class	II according to VDE 0106
Degree of contamination	2 according to VDE 0110
Overvoltage category	II according to VDE 0110
Humidity class	F according to VDE 40040
Noise immunity	According to EN 50082 Part 1
Noise emission	According to EN 50081 Part 1
Weight	Approx. 0.6 kg

1) Avoid areas with poor ventilation to prevent heat from building up

Electrical connection and assembly

The ventilation controller consists of an electronics section which can be found in the controller case and a rear case unit with the terminal blocks. Two wires with a minimum cross section of 0.5 mm² can be connected to each terminal.

Sensor leads are to be wired separately from the lines of the output relays.

With the wall-mounted version, the rear case unit is screwed to the wall. After connecting the electrical leads, the controller case is inserted on the rear case unit and fastened with two screws.

With the panel-mounted version, the controller is mounted in the control panel using two mounting clamps.

For the top hat rail, there are two fixed hooks and one spring-mounted hook on the rear side of the device.

Ordering text

TROVIS 5177 Ventilation Controller with RS-232 interface.

Dimensions in mm

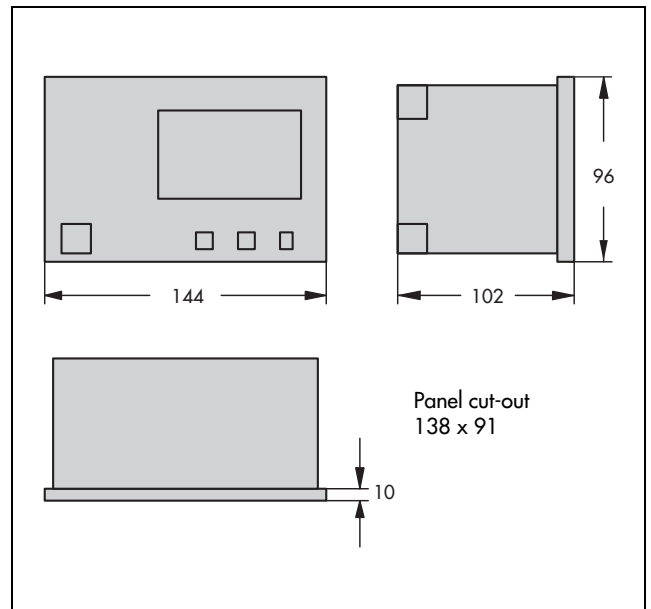

Terminal assignment

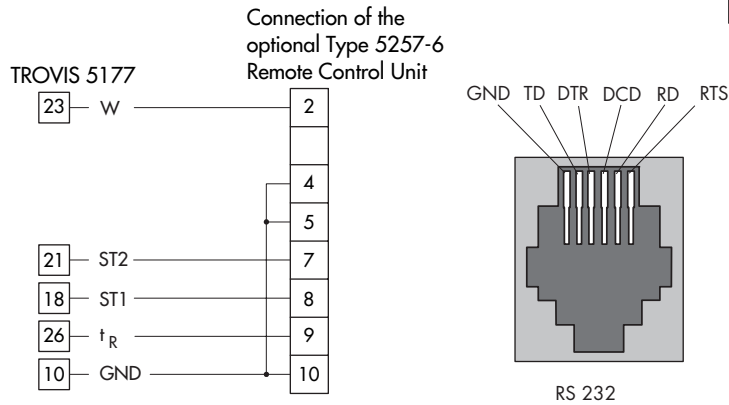
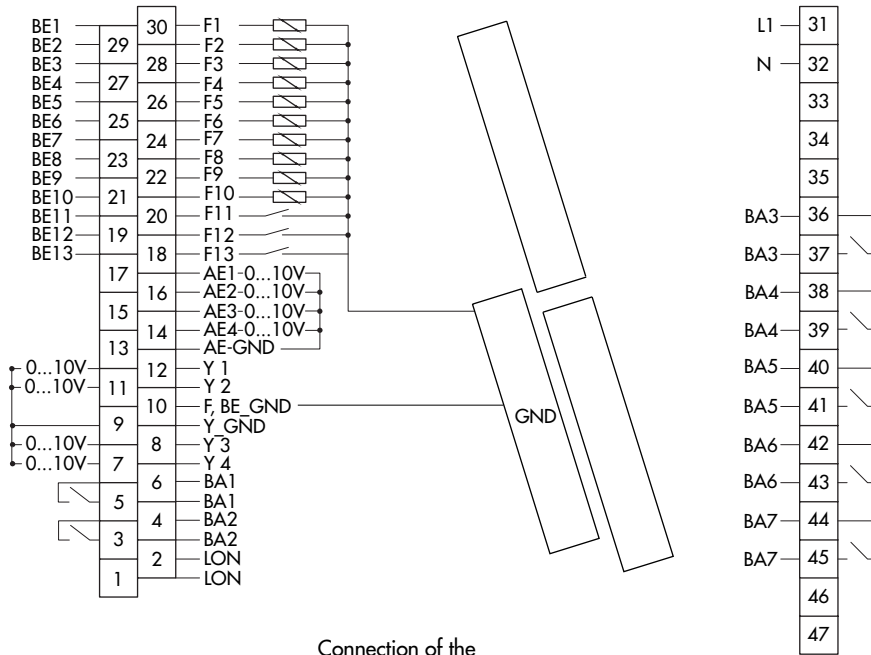

AA Analog output
 AE Analog input
 BA Binary output
 BE Binary input
 F Sensor or potentiometer input
 GND Ground

ST1 Fan stage 1
 ST2 Fan stage 2
 t_R Room temperature
 W Temperature set point
 Y Output of manipulated variable