

Automation System TROVIS 5100

Heating Controller TROVIS 5179



Application

Self-optimizing, weather-sensitive flow temperature control of hot water heating systems and hot water temperature control in up to three control circuits · Communication with a control station



The TROVIS 5179 Heating Controller performs weather-sensitive flow temperature control for heating systems with maximum three heating circuits. The return flow temperatures can be limited with respect to the outdoor temperature. Drinking water heating can be included in the control system in a primary or secondary circuit.

Special features:

- Adaptation of control parameters
- Self-optimization with and without room sensor
- Short-term adaptation
- Delayed outdoor temperature adaptation
- Automatic summertime/wintertime changeover
- Time-based and outdoor temperature-based summer mode
- Thermal disinfection of drinking water storage tank
- Forced pump operation
- Transmission of required temperature
- Transmission of temperature values at the sensors to other controllers via LON
- Connection to Modbus is possible
- RS 232 interface for communication with a modem
- Optional interface for meter bus

Versions

TROVIS 5179 (Fig. 1) · Heating controller with RS 232 and LON interface



Fig. 1 · TROVIS 5179 Heating Controller

Inputs and outputs (Fig. 2)

Input and output assignments of the heating controller are determined by the system code number (see examples in Figs. 9 and 10).

To determine the required temperatures, the following sensors are suited: Pt 100, Pt 1000, Ni 200, Ni 1000 and PTC sensors, also applicable in combinations.

The controller is equipped with one input per control circuit for the connection of a potentiometer.

For the limitation of the capacity/flow rate, the controller provides the following two possibilities:

- A calorimeter signal which is proportional to the volume flow can be applied to a pulse-counting input or
- a meter bus master module is used to connect up to three calorimeters via meter bus.

The TROVIS 5179 Heating Controller can transmit the highest flow temperature setpoint to a primary circuit controller.

The controller is equipped with three three-step outputs for controlling the relevant control valves and five binary outputs to control the heating circulation pump, the storage charging pump, the heat exchanger charging pump and the drinking water circulation pump. Four binary outputs for small heating capacities can be used to control the speed of circulation pumps.

The RS 232 interface allows the heating controller to be integrated in a control system. Using a cable adapter, the unit can also be optionally connected to a RS 485 bus.

Operation (Fig. 3)

The heating controller can be adapted to the required control task by using the operator controls directly on the front panel as shown in Fig. 3.

The controller is designed for different types of systems which are briefly presented in the Table "System code numbers" on page 3.

The user is required to select the type of his heating system by entering the corresponding system code number. This system code number does not only determine the assignment of the inputs and outputs, but also the different function blocks and parameters to be selected. These must then be adjusted separately for each control loop. The required details are prompted in sequence. Symbols appear on the LCD (5) to support configuration and parameterization.

The function blocks in the configuration level are used to define e.g. the type of signal output (on/off, three-step output) as well as different functions, such as drinking water heating, adaptation, summer mode, etc.

The parameters determine, for example, the characteristic heating curve gradient, the return flow characteristic and vacation periods.

Some of the function blocks can be protected against unauthorized access by means of a code number.

The mode selector switch (1) enables the user to switch between time-based operating mode, rated operation, reduced and stand-by operation as well as manual operation for each control circuit.

The memory module (2) is used to copy all configuration and parameterization data from one controller to another.

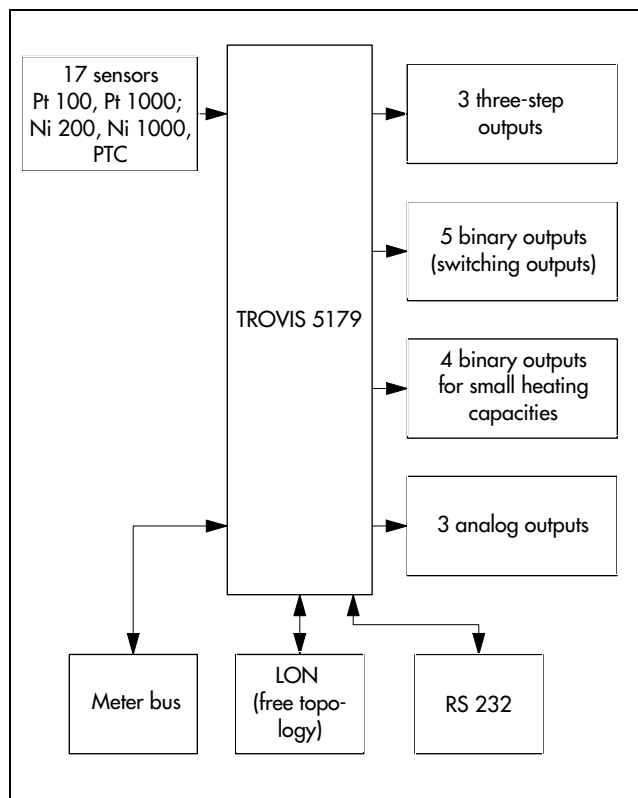
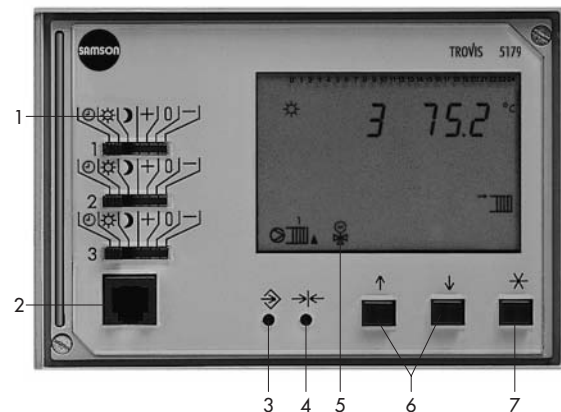

Fig. 2 · Inputs and outputs



- | | |
|---|--|
| 1 Mode selector switch for control circuit 1 to 3 | 4 Standard key (resetting to default values) |
| 2 Female connector for memory module | 5 LCD |
| 3 Selector key (access to parameterization and configuration level) | 6 Enter keys |
| | 7 Accept key |

Fig. 3 · Operating controls of the TROVIS 5179 Heating Controller

Adaptation of the heating characteristic (Figs. 4 and 5)

The heating characteristic can be automatically adapted by the heating controller if a room temperature sensor is connected. The assignment of the flow temperature and the outdoor temperature is determined according to the room temperature.

Limit values can be defined for the minimum and the maximum flow temperature.

Manual adjustment of the characteristic (Figs. 4 to 6)

The heating characteristic can be manually adjusted by entering either a gradient value (see Fig. 4) or any of four coordinates (Fig. 6). These coordinates must be determined within a flow temperature t_V range of 20 to 120 °C and an outdoor temperature t_A range of -20 to 50 °C. In addition, the user can define limit values for the maximum and minimum flow temperature. If required, parallel displacement of the characteristic is possible. In this case, the limit values for the flow temperature remain unchanged.

The return flow temperature characteristic (Fig. 5) is also determined by entering either a gradient value or any of four coordinates, a maximum and minimum limit value and, if required, parallel displacement.

Optimizing switch-on and switch-off times

The heating controller automatically optimizes switch-on and switch-off times of the heating system in periodically used buildings, thus minimizing energy consumption. The controller determines the building's thermal characteristic and the dynamic behavior of the heating system by measuring the room and outdoor temperature over a certain period of time. These data are then used to calculate the optimum switch-on and switch-off times.

Self-optimization can be performed with or without using a room sensor.

Without connected room sensor, the switch-on time is shifted as a function of the outdoor temperature. During periods of non-use, a definable reduced flow set point is used to operate the heating system (reduced operation). If a certain outdoor temperature value is exceeded, the heating system is switched off.

A connected room sensor permits the monitoring of an adjustable sustaining room temperature value during periods of non-use. If necessary, the heating system is put into operation over a short period of time.

Electrical connections and mounting

The controller housing with the electronics unit as well as a separate terminal board for electrical connection are part of the heating controller. Each screw terminal can take two 0.75 mm² wires. The connecting lines of the sensors must be laid separately from the output lines.

For wall mounting, the terminal board must be screwed to the wall. After the electrical connections have been installed, the controller housing is plugged on the terminal board and secured with two screws.

For panel mounting, the controller is clipped into the control panel.

Ordering text

TROVIS 5179 Heating Controller

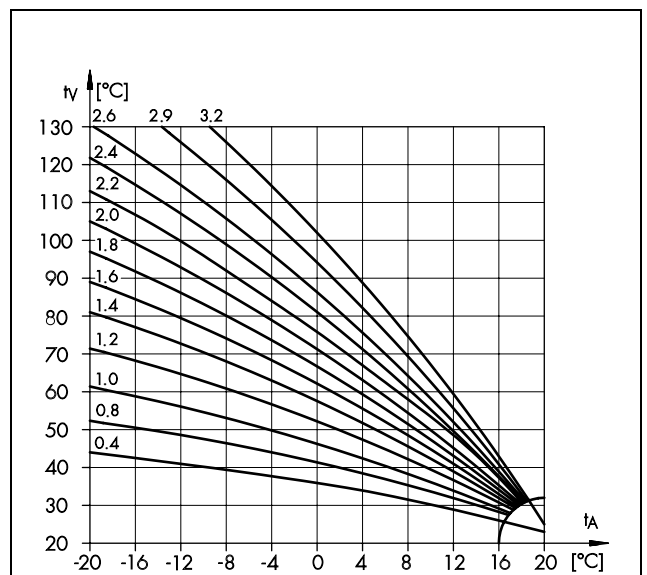

Fig. 4 · Heating characteristics

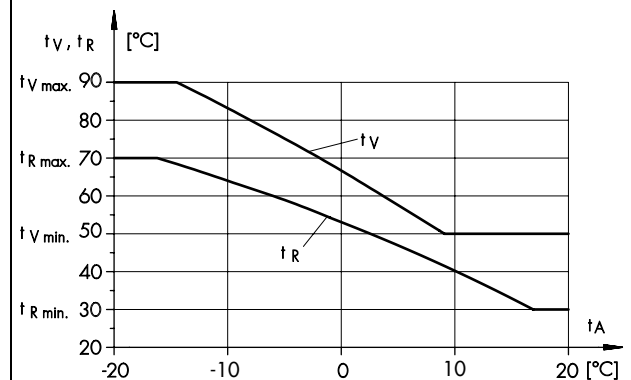

Fig. 5 · Weather-sensitive flow temperature control with variable return flow temperature limitation

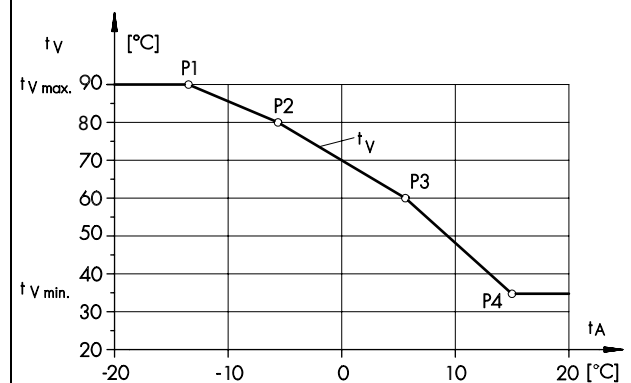

Fig. 6 · Characteristic with four coordinates

t_V	Flow temperature	...min.	Minimum t_R or t_V
t_R	Return flow temperature	...max.	Maximum t_R or t_V
t_A	Outdoor temperature	P1 to P4	Coordinates 1 to 4

System code numbers

System code number	System description	Comment
1	Two heating circuits, indirect connection	
2	Two heating circuits, indirect connection, one secondary drinking water heating circuit with storage charging system	Drinking water heating without control valve in the priority circuit
3	Three heating circuits, indirect connection	Third heating circuit without control valve
4	One heating circuit, indirect connection, one secondary drinking water heating circuit with storage charging system	
5	Two heating circuits, indirect connection, one secondary drinking water heating circuit with storage charging system	Second heating circuit without control valve
6	Three heating circuits, direct connection	
7	One heating circuit, indirect connection, one primary drinking water heating circuit with storage charging system	
8	Two heating circuits, indirect connection, one primary drinking water heating circuit with storage charging system	Second heating circuit without control valve
9	Two heating circuits, direct connection, one drinking water heating circuit with storage charging system	

Technical data

Inputs Sensor inputs and binary inputs	Depending on selected system code no. Max. 17 configurable inputs for temperature sensors (Pt 100, Pt 1000, Ni 200, Ni 1000 and PTC) or binary messages as follows. 5 flow temperature sensors 3 room temperature sensors 3 outdoor temperature sensors 3 return flow temperature sensors 2 storage temperature sensors
Outputs Control signal y	Depending on selected system code no. Three-step signal: Max. load: 250 V~, 3 A On/off signal: Max. load: 250 V~, 3 A Continuous control signal: 0 to 10 V (load > 4.7 kΩ)
Binary outputs	5 outputs for controlling pumps, Max. load: 250 V~, 2 A; 4 binary outputs for pump control, Max. load: 50 V~, 100 mA
Interfaces	RS 232 for connection to a modem, interface for meter bus, LON (free topology)
Power supply	230 V, 48 to 62 Hz, power output 8 VA
Ambient temperature	0 to 40 °C (storage -20 to 60 °C)
Degree of protection	IP 40 according to IEC 529
Class of protection	I according to VDE 0106
Degree of contamination	2 according to VDE 0110
Overvoltage category	II according to VDE 0110
Humidity class	F according to VDE 40040
Noise immunity	According to EN 50082 Part 1
Noise emission	According to EN 50081 Part 1
Weight	Approx. 0.6 kg

Dimensions in mm

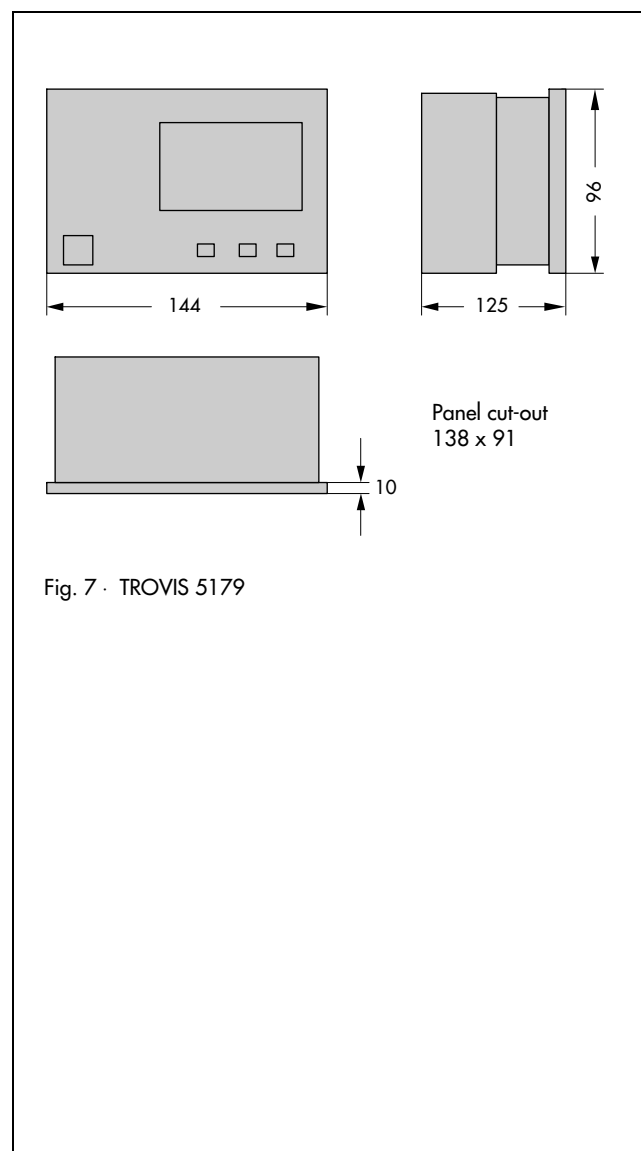

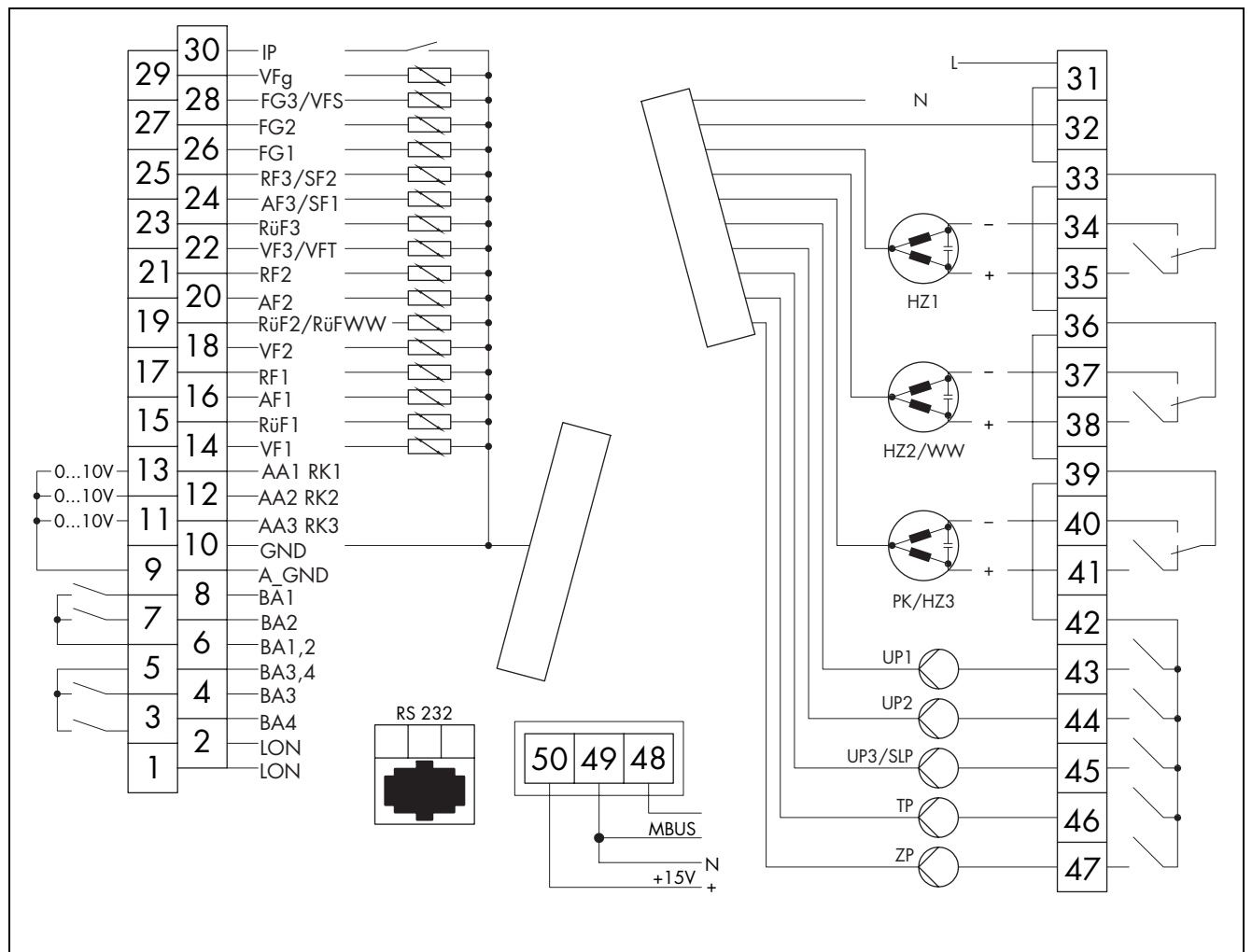

A_GND	Common analog ground	RüF1 to RüF3	Return flow temperature sensors for control circuit 1 to 3
AA	Analog output	RüFWW	Return flow temperature sensors for drinking water preparation
AF1 to AF3	Outdoor temperature sensor for control circuit 1 to 3	SF1	Storage sensor On
BA1 to BA4	Binary output 1 to 4	SF2	Storage sensor Off
F_GND	Common sensor ground	SLP	Storage charging pump
FG1 to FG3	Potentiometers for control circuit 1 to 3	TP	Heat exchanger charging pump
GND	Common ground	UP1 to UP3	Circulation pumps heating circuit 1 to 3
HZ1 to HZ3	Control valve heating circuit 1 to 3	VF1 to VF3	Flow temperature sensor in control circuit 1 to 3
IP	Pulse-counting input	VFg	Flow temperature sensor in the primary circuit
LON	LON interface	VFS	Flow temperature sensor storage
MBUS	Meter bus	VFT	Flow temperature sensor heat exchanger
PK	Control valve primary circuit	WW	Control valve drinking water heating
RF1 to RF3	Room temperature sensor for control circuit 1 to 3	ZP	Circulation pump

The diagram shows the maximum possible equipment. Depending on the selected system code number, the assigned inputs and outputs vary.

Fig. 8 · TROVIS 5179 terminal assignment

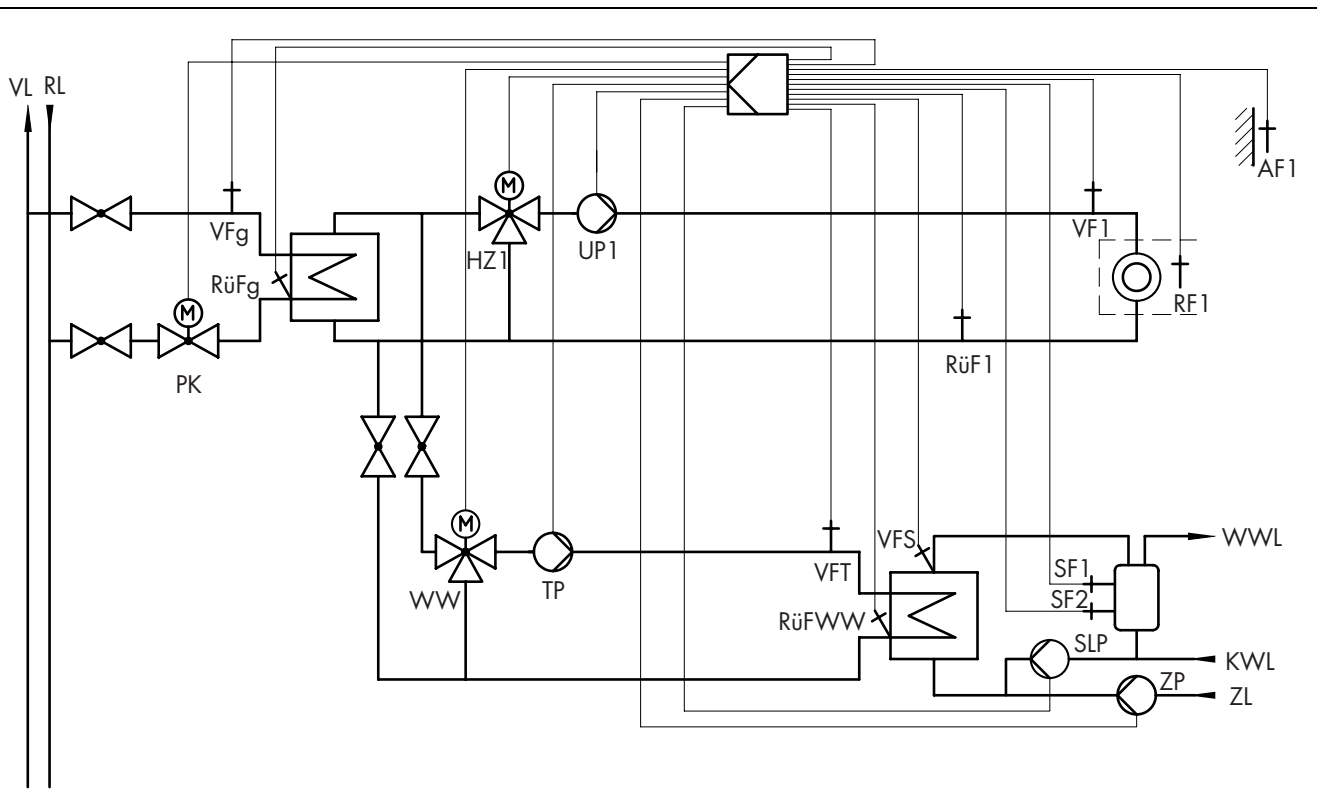

Fig. 9 · System code number 4

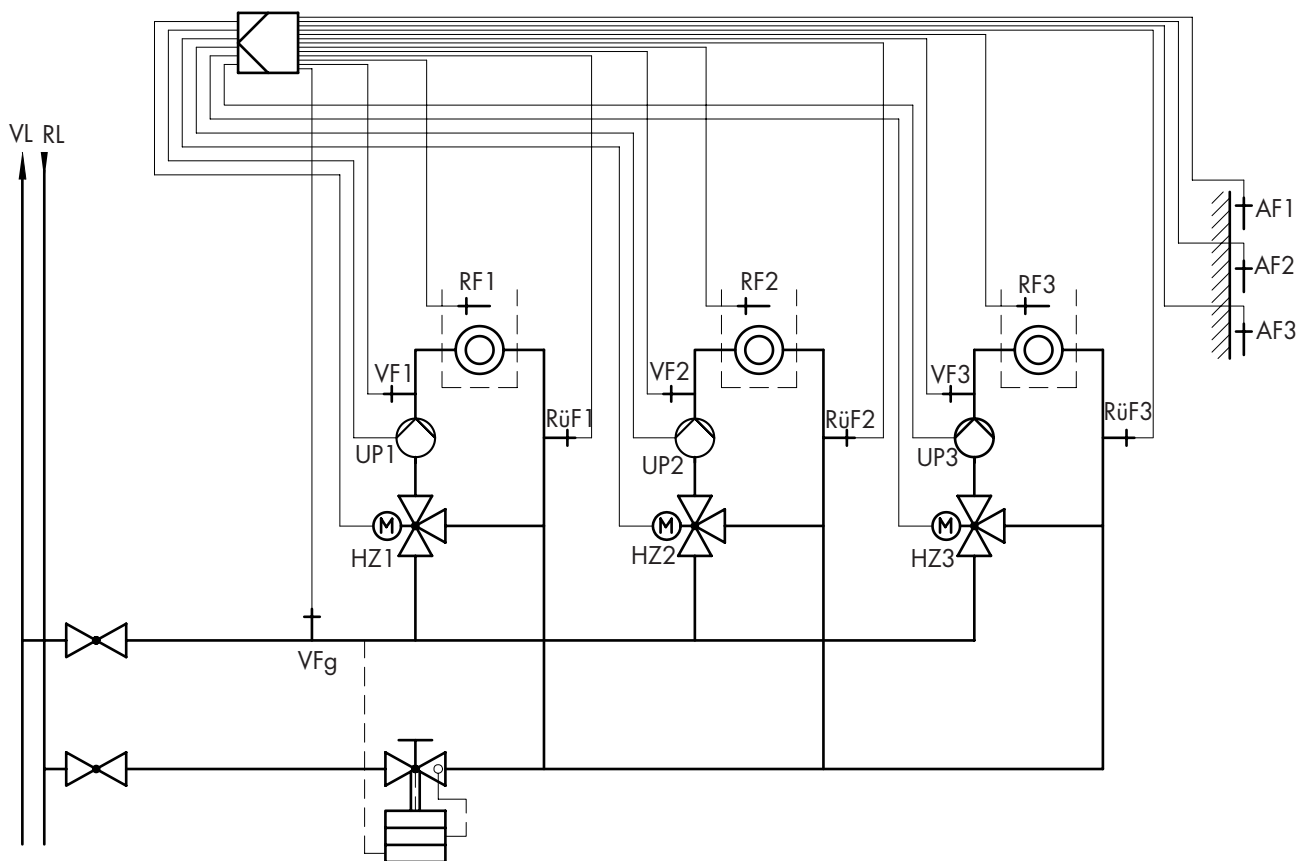

Fig. 10 · System code number 6

VL Flow pipe
 RL Return flow pipe
 WWL Hot water pipe

KL Cold water pipe
 ZL Circulation pipe
 For further abbreviations, see Fig. 8.

