

Automation System TROVIS 5400

Boiler Controller TROVIS 5474



Application

Weather-sensitive control of up to two boilers, designed for single-stage, two-stage or also modulating operating mode. Communication with a control system via the RS 232 interface.



The boiler controller TROVIS 5474 works according to single-stage, two-stage or modulating operating mode and is used for weather-sensitive control or for fixed set point control of boiler installations including up to two boilers. This controller is able to control higher flow temperatures than stipulated by its own boiler characteristic when demanded so by downstream controllers.

The return temperature may be increased either separately for each boiler or for all of them together.

Single-boiler installations allow the connection of an additional heating loop for domestic hot water.

Special features:

- Fixed or variable boiler operation
- Return temperature increase via pump control for each individual boiler
- Boiler start-up control
- Minimum switch-on and switch-off time per boiler
- Reduction of excessive boiler temperature through forced charging of the drinking water storage tank
- Safety shut-down in case of excessive boiler temperature
- Automatic sequence reversal according to operating hours, outdoor temperature or in case of malfunction
- Differential temperature control using variable weighting factors
- Forced actuation of pumps
- Connection to Modbus is possible
- Interface RS 232 for communication with a modem
- Interface for meter bus

Version

TROVIS 5474 (Fig. 1) · Boiler controller with RS 232 interface



Fig. 1 · TROVIS 5474 Boiler Controller

Inputs and outputs (Fig. 2)

The inputs and outputs of the boiler controller are settled by the system code number.

To determine the required temperatures, the following sensors are suited: Pt 100, Pt 1000, Ni 200, Ni 1000 and PTC sensors, also applicable in combination. The outdoor temperature can also be processed by a 0 to 10 V analog output.

The controller has got two three-step signal outputs or analog outputs responsible for the increase of the return temperature. Six binary outputs control the boiler pump and the boiler stages.

Two other binary outputs assigned to small heat outputs indicate malfunctions or forced charging of the drinking water storage tank.

The meter bus interface allows the connection of up to three calorimeters or flow meters.

The RS 232 serial interface enables the boiler controller to be integrated in a control system.

Operation (Fig. 3)

The boiler controller can be directly adapted to the required control task by means of the operating controls illustrated in Fig. 3.

The controller is designed for different types of installations which are briefly presented in the Table listing the system code numbers.

First of all, the user is required to choose the type of installation by entering the corresponding system code number. The system code number not only determines the assignment of the inputs and outputs but also the different function blocks and parameters to be selected. These must then be adjusted separately for each control loop (5, 8, 9). The necessary details are inquired in succession. Symbols are indicated on the display (7) to facilitate configuration and parameterization.

The function blocks in the configuration level are used to define e.g. the type of signal output (on/off, three-step or continuous signal output) as well as diverse functions such as sequence reversal, summertime compensation and more. Some of the function blocks are protected against unauthorized access by a code. In addition, there is one function block which ensures protection of all the other function blocks and parameters against unauthorized changes.

The parameters, for example, determine the boiler characteristic, limit values and times of unoccupied periods.

Three sliding switches are used to set the operating mode (1) and the boiler operating mode (2) or allow manual correction of the flow temperature set point (3). There are six possible operating modes: automatic operation with night set-back, automatic operation with boiler shut-down during night-time but domestic hot water, rated operation always, reduced operation, maintenance operation and finally stand-by operation, i.e. domestic hot water on demand and frost protection. There are also different boiler operating modes, these are: both boilers in operation with automatic sequence reversal, either boiler 1 or boiler 2 in operation, both boilers shut-down, boiler 2 follows up, or boiler 1 follows up.

All of the configuration and parameterization data can be generated via a PC editor and transmitted to the boiler controller via the memory module (4).

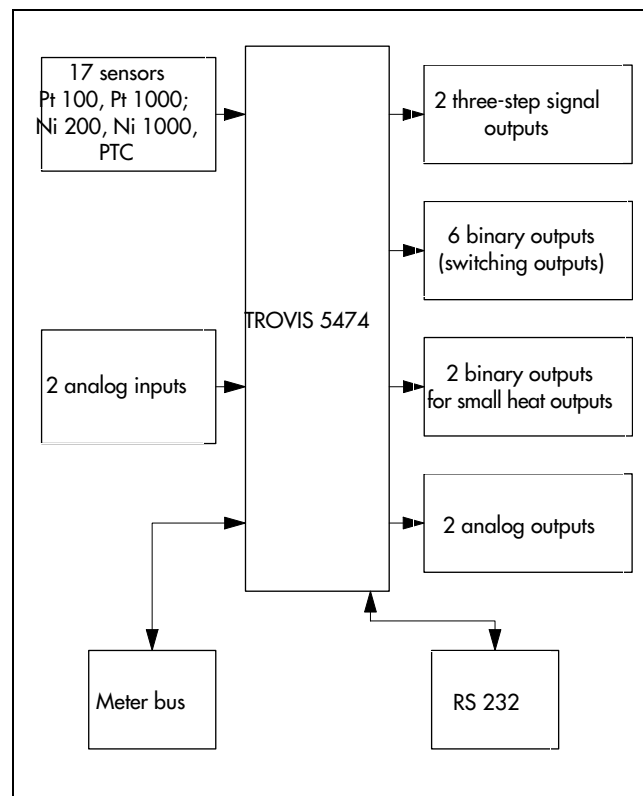
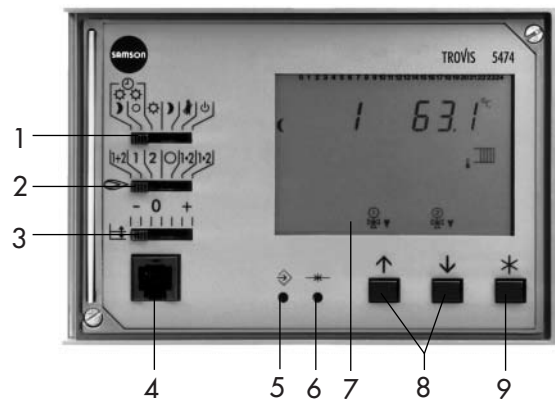

Fig. 2 · Inputs and outputs



- | | |
|--|---|
| 1 Mode selector | 5 Selector key (access to parameterization and configuration level) |
| 2 Selection of the boiler operating mode | 6 Standard key (resetting to default values) |
| 3 Correction of the flow temperature set point | 7 Display |
| 4 Female connector for memory module | 8 Enter key |
| | 9 Accept key |

Fig. 3 · Operating controls of the TROVIS 5474 Boiler Controller

Manual adjustment of the characteristic (Fig. 4)

The boiler controller can be operated by adjustable boiler characteristic or by fixed flow temperature. In both cases, the flow temperature set point can be reduced during unoccupied periods.

The boiler characteristic is determined by entering four arbitrary points (Fig. 4). These points are established at flow temperatures t_V from 20 to 120 °C and outdoor temperatures t_A from -20 to 50 °C. The maximum and minimum flow temperature can be defined by limit values.

Electrical connection and assembly

The controller consists of the controller housing together with the electronic equipment and the back side with the terminal block. Each terminal can be connected to 2 wires having a 0.75 mm² cross-section. The connecting lines of the sensors must be installed separately from those of the output relays.

For wall mounting, the back side of the housing must be screwed to the wall. After the electrical connections have been installed, the controller housing must be placed on its back side and secured using two screws.

For panel mounting, the controller is installed in the panel using two mounting parts.

At the back side of the housing, there are small hooks which enable the controller to be mounted on a top-hat rail.

Ordering text

TROVIS 5474 Boiler Controller with RS 232 interface

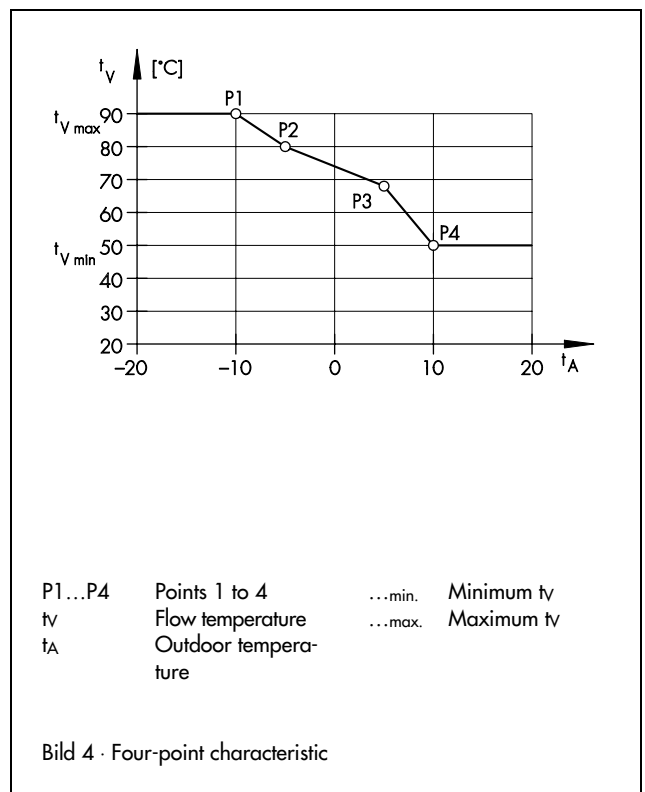

System code numbers

System code number	Plant description	Functions
1	Single-boiler installation with single-stage burner	Return temperature control optionally with an on/off, three-step or continuous output signal; Automatic boiler shut-down in case of malfunction; Separate drinking water heating and heating circuit control
2	Single-boiler installation with two-stage burner	
3	Single-boiler installation with modulating burner	Return temperature control optionally with an on/off, three-step or continuous output signal; Feedback of modulating burner via position transmitter or limit switch; Automatic boiler shut-down in case of malfunction Separate drinking water heating and heating circuit control
4	Two-boiler installation for single-stage condensing value boiler and two-stage low temperature boiler	Return temperature control optionally with an on/off, three-step or continuous output signal; Boiler sequence control without reversal; Automatic boiler shut-down in case of malfunction
5	Two-boiler installation with two two-stage burners	Return temperature control optionally with an on/off, three-step or continuous output signal; Adjustable follow-up delay; Automatic sequence reversal either acc. to adjustable operating hours intervals or outdoor temperature; Automatic boiler shut-down in case of malfunction
6	Two-boiler installation for modulating or two-stage burner	Return temperature control optionally with an on/off, three-step or continuous output signal; Feedback of modulating burner via position transmitter or limit switch; Boiler sequence control without reversal; Adjustable follow-up delay; Automatic boiler shut-down in case of malfunction
7	Boiler sequence control for two modulating burners	Return temperature control optionally with an on/off, three-step or continuous output signal; Adjustable follow-up delay; Feedback of modulating burner via position transmitter, Automatic sequence reversal either acc. to adjustable operating hours intervals or outdoor temperature

Technical data

Inputs	Depending on the selected system code number
Sensor inputs and binary inputs	Max. 17 configurable inputs for temperature sensors (Pt 100, Pt 1000, Ni 200, Ni 1000, PTC) or binary messages, this includes 1 flow temperature sensor 2 boiler temperature sensors 1 outdoor temperature sensor 3 return temperature sensors 2 for boiler release 2 for status points 4 for fault messages
Further inputs	2 analog inputs 0 to 10 V
Outputs	Depending on the selected system code number
Control signal y	Three-step signals: Load: max. 250 V ₋ , 2 A On/off signals: Load: max. 250 V ₋ , 2 A Continuous control signal: 0 to 10 V ₋ ; perm. load >4.7 kΩ
Binary outputs	6 outputs for controlling pumps and boilers Load: max. 250 V ₋ , 2 A 2 outputs for messages Load: max. 50 V ₋ , 100 mA
Interfaces	RS 232 for connection to a modem; Interface for meter bus
Power supply	230 V, 48 to 62 Hz, power output 8 VA
Ambient temperature	Permissible 0 to 40 °C
Degree of protection	IP 40 according to IEC 529
Class of protection	I according to VDE 0106
Degree of contamination	2 according to VDE 0110
Overvoltage category	II according to VDE 0110
Humidity rating	F according to VDE 40040
Noise immunity	According to 50082 Part 1
Noise emission	According to 50081 Part 1
Weight	approx. 0.6 kg

Dimensions in mm

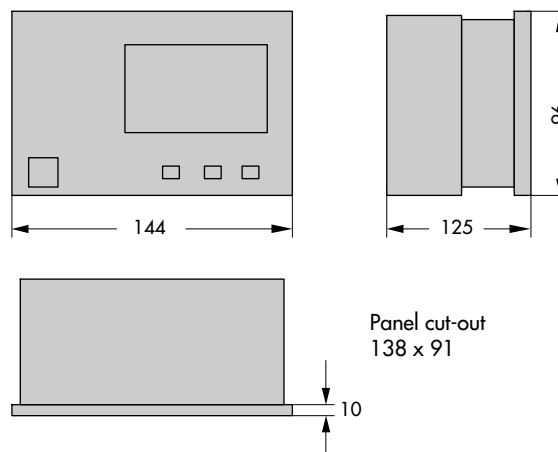
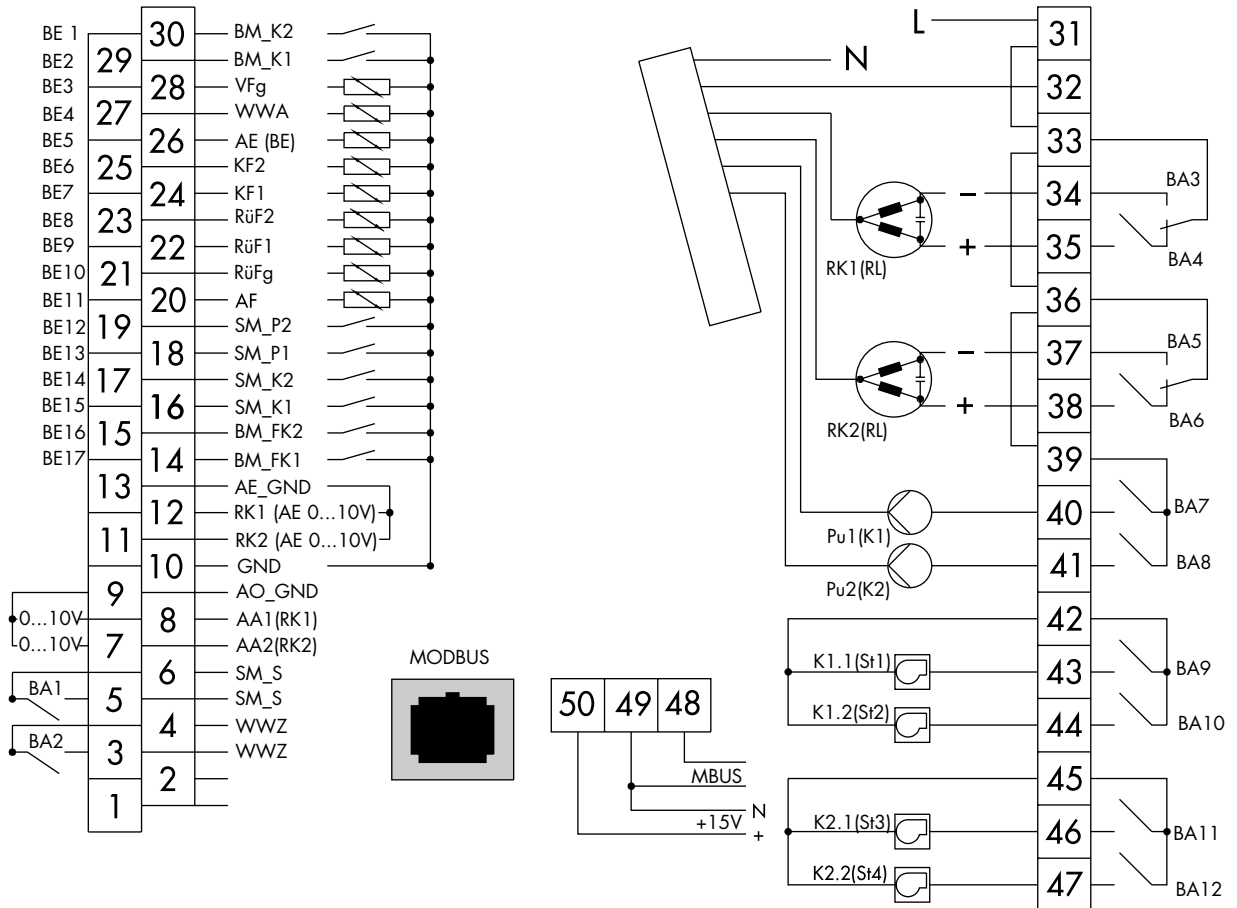

Fig. 5 · TROVIS 5474



AA	Analog output
AE	Analog input
AE_GND	Common ground of analog inputs
AF	Outdoor temperature sensor
AO_GND	Common ground of analog outputs
BA	Binary output
BE	Binary input
BM_FK	Status point, boiler 1, 2 released
BM_K	Status point, boiler 1, 2
GND	Common ground
K	Boiler 1, 2
K	Boiler temperature sensor 1, 2

MBUS	Connection for meter bus
Pu	Pump 1, 2
RK	Control loop 1, 2
RL	Return flow
RüF	Return temperature sensor
RüFg	Return temperature sensor, for the entire system
SM_K	Fault message, boiler
SM_P	Fault message, pump
SM_S	Centralized fault
St	Stage 1 to 4
VFg	Flow temperature sensor, for the entire system
WWA	Drinking water demand
WWZ	Forced charging of drinking water storage tank

The Fig. shows the maximum equipment. Depending on the selected system code number, the assignment of the inputs and outputs varies.

Fig. 6 · Terminal assignment for TROVIS 5474

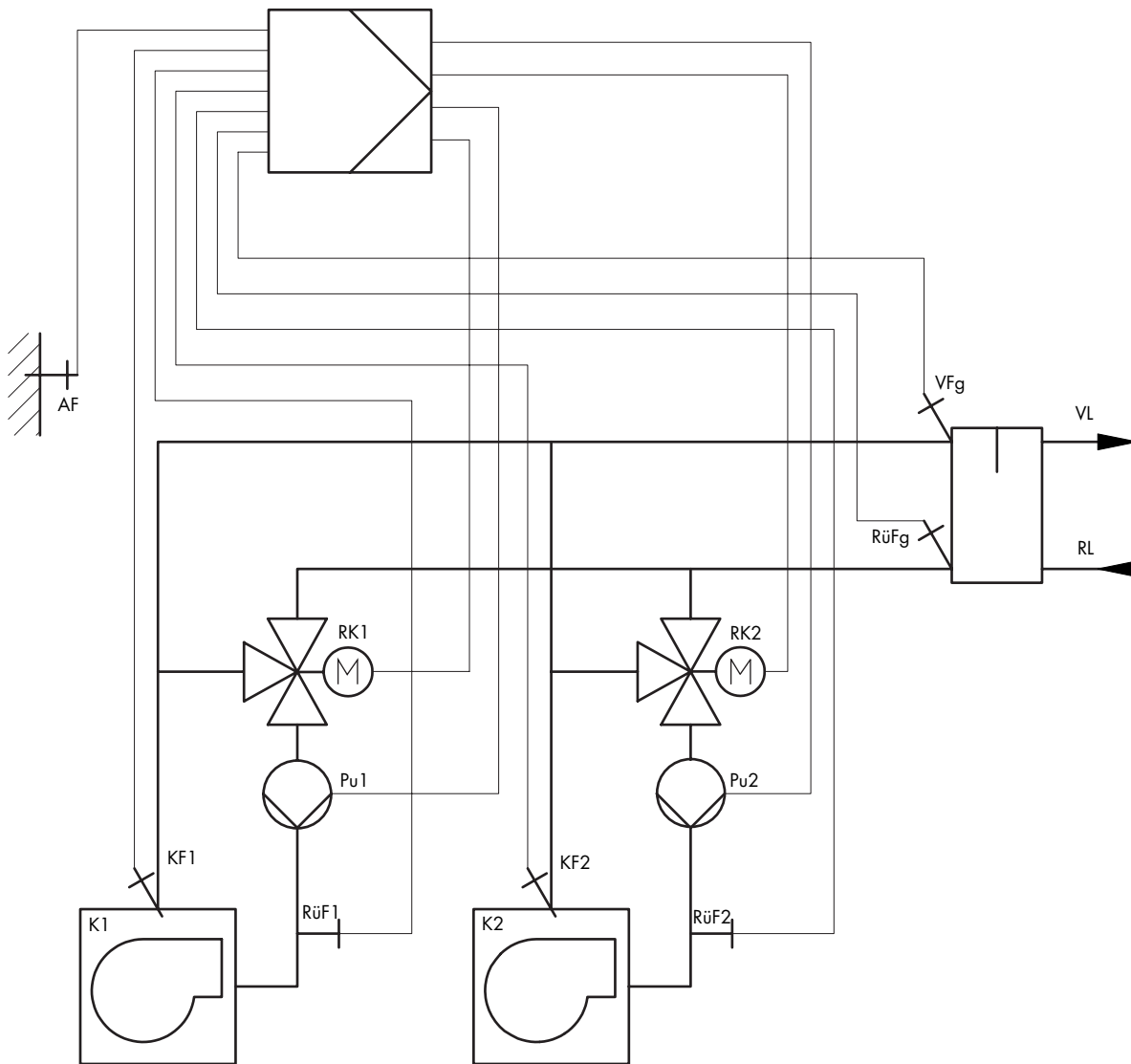

AF Outdoor temperature sensor
 K Boiler 1, 2
 KF Boiler sensor 1, 2
 Pu Pump 1, 2
 RK Control loop 1, 2

RL Return flow
 RüF Return temperature sensor 1, 2
 RüFg Return temperature sensor, for the entire system
 VFg Flow temperature sensor, for the entire system
 VL Flow

Fig. 7 · System code number 5

