

Automation System TROVIS 5400

District Heating Controller TROVIS 5479



Application

Self-optimizing, weather-sensitive flow temperature control in hot water heating systems and hot water temperature control for up to three control loops · Allows communication with a process control system.



The TROVIS 5479 District Heating Controller provides weather-sensitive flow temperature control in heating systems incorporating a maximum of three heating circuits. The return flow temperatures can be limited with respect to the outdoor temperature. Drinking water heating can be included in the control process either in the primary or in a secondary circuit.

Special features:

- Adaptation of the control parameters
- Optimization without and with room sensor
- Short-time adaptation
- Delayed outdoor temperature adaptation
- Automatic summertime/wintertime changeover
- Time and outdoor temperature-based summer mode
- Thermal disinfection of the hot water storage tank
- Forced pump operation
- Option of external connection of the heat demand
- Connection to Modbus is possible
- RS-485 interface for communication with a bus system, or RS-232 interface for communication with a modem
- Optional interface for meter bus

Versions

TROVIS 5479 (Fig. 1) · District heating controller with RS-232 or RS-485 interface

Option: Meter bus-master module



Fig. 1 · TROVIS 5479 District Heating Controller

Inputs and outputs (Fig. 2)

The input and output assignments of the district heating controller are determined by the entered system code number (for example, see Figs. 11 and 12).

Pt100/Pt1000, Pt100/PTC and Pt100/NTC sensors (also several combinations of each) can be used to measure the required temperatures. The measured outdoor temperature can also be applied to the controller as a current signal in the range from 0 to 20 mA.

The district heating controller has an input for each control loop to connect a potentiometer.

The heat output or volume flow of the system can be limited in two ways:

- The signal from a calorimeter, which is proportional to the volume flow rate, can be connected to a pulse-counting input or
- When a meter bus-master module is used, up to three calorimeters can be connected to the controller via the meter bus.

In certain system types, the highest flow temperature set point can be transferred from one TROVIS 5479 District Heating Controller to the next when several controllers are connected in series (external connection to heat demand).

The controller features three three-step outputs for controlling the corresponding control valves, and five binary outputs for controlling the heating circulation pumps, the storage charging pump, the heat exchanger charging pump and the circulation pump. Four transistor outputs can be used to control the rotational speed of circulation pumps.

The district heating controller can be integrated in a control system by means of a serial interface. The controller is available with either a RS-485 or RS-232 interface.

Operation (Fig. 3)

Adaptation of the district heating controller to the required control tasks can be carried out using the front panel operator controls shown in Fig. 3.

The controller can be used in different types of systems which are described in the table "System code numbers".

First, the user must select one of these system types by entering the corresponding code number. This system code number not only determines the assignment of inputs and outputs, but also which function blocks and parameters have to be selected. Subsequently, these have to be entered separately for each control loop. The user is prompted step by step to enter the required data. Input of configuration data and parameters is supported by means of symbols displayed on the LC display panel (5).

The function blocks in the configuration mode are used to define, for example, the type of outputs (on-off, three-step output) and different functions such as priority of drinking water heating, adaptation, summer mode and others.

The parameters determine, for instance, the gradient of the heating curve, the return flow characteristic and holiday schedules.

Several function blocks are protected with a code number against unauthorized access.

The mode selector switch (1) can be used to switch for each control loop between time-based operation, nominal operation, reduced and stand-by operation, as well as manual operation.

With the memory module (2), all configuration and parameter data can be duplicated from one district heating controller to another.

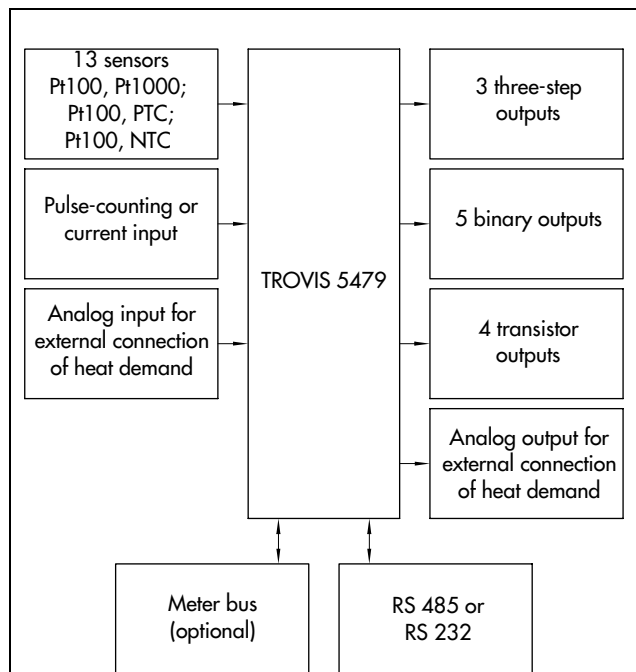
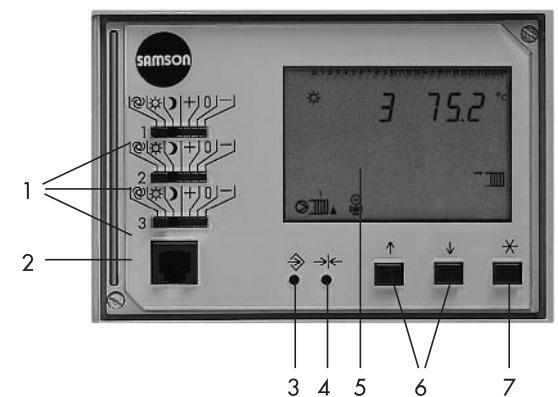

Fig. 2 · Inputs and outputs



- | | |
|---|---|
| 1 Mode selector switch for control loops 1 to 3 | 4 Standard button (reset to default values) |
| 2 Connecting socket for memory module | 5 LC display |
| 3 Changeover button (access to parameterization and configuration mode) | 6 Cursor keys |
| | 7 ENTER key |

Fig. 3 · Operator controls of the TROVIS 5479 District Heating Controller

Adaptation of the controller's heating curve (Figs. 4 and 5)

The district heating controller provides an option of automatically adapting the heating curve to the required system conditions when a room sensor is connected. The controller determines the correlation between flow temperature and measured outdoor temperature depending on the room temperature.

Minimum or maximum flow temperature limitation is supported.

Manual setting of the characteristic heating curve (Figs. 4 to 6)

The heating curve may be set manually by entering either a gradient value (s. Fig. 4) or any of four coordinates (Fig. 6). In this case, four flow temperature values t_V in the range from 20 to 120 °C, as well as outdoor temperature values t_A in the -20 to 50 °C range are to be entered. In addition, a maximum and minimum flow temperature limit value may be entered. If required, a parallel displacement of the heating curve is possible. In this case, the flow temperature limit values are not changed.

The return flow temperature characteristic (Fig. 5) is also determined by entering the following: a corresponding gradient value or any of four coordinates, the maximum and minimum limits and, if necessary, a parallel displacement of the curve.

Optimizing switch-on and switch-off times

The district heating controller is capable of automatically optimizing the switch-on and switch-off times of the heating system in periodically used buildings to reduce energy consumption. The controller determines the building's thermal characteristic and dynamic behavior of the heating system from the succession of room and outdoor temperature measurement over a certain period of time.

This optimization function can be carried out either with or without a room temperature sensor.

When no room temperature sensor is connected, the switch-on time is changed depending on the outdoor temperature. During periods of nonuse, the heating cycles with a definable, reduced flow temperature set point (reduced operation). The heating is switched off when the outdoor temperature exceeds a certain value.

When a room temperature sensor is connected, the heating cycles in the stand-by mode during periods of nonuse. The controller monitors the room temperature during periods of nonuse for not falling below an adjustable sustaining temperature value. If necessary, the heating system is switched on for a short moment.

Electrical connection and mounting

The controller consists of a controller housing containing the electronic components and a separate terminal board used for the electrical connection. 2 wires of max. 0.75 mm² can be connected to each terminal. The sensor connection lines must be installed separately from the output relay lines.

For wall mounting, the terminal board must be fastened to the wall using screws. After having made all electrical connections, the controller housing must be plugged onto the terminal board and secured with screws.

For panel mounting, the controller is slid into the control panel.

Ordering text

TROVIS 5479 District Heating Controller with a RS-485 or RS-232 interface.

Meter bus-master module

External power supply unit for meter bus-master module

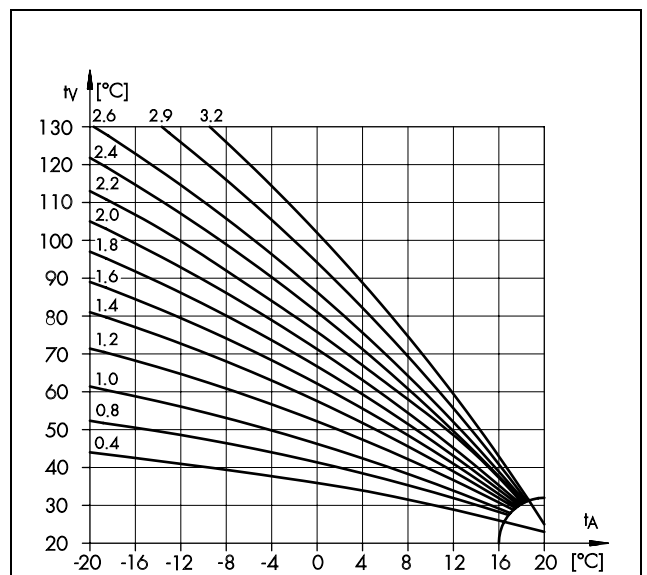

Fig. 4 · Characteristic heating curves

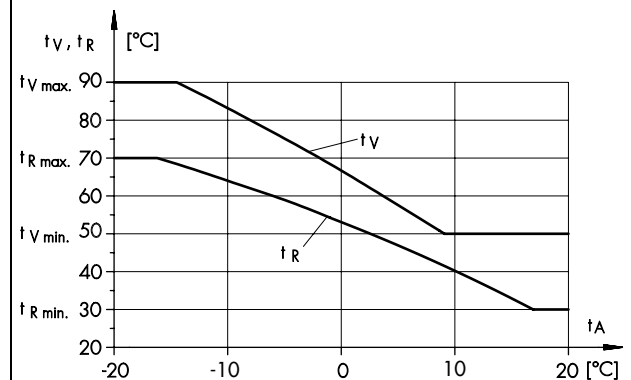

Fig. 5 · Weather-sensitive flow temperature control with variable return flow temperature limitation

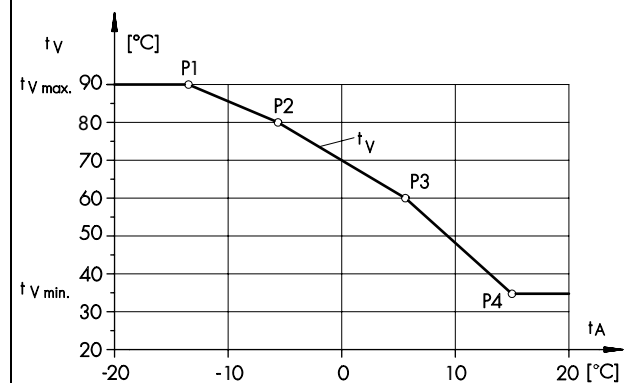

Fig. 6 · Characteristic heating curve with four coordinates

t_V	Flow temperature	...min.	Minimum t_R or t_V
t_R	Return flow temperature	...max.	Maximum t_R or t_V
t_A	Outdoor temperature	P1 to P4	Coordinates 1 bis 4

System code numbers

System code no.	Description of system	Comment
1	Two heating circuits, indirect connection	
2	Two heating circuits, indirect connection, one drinking water heating circuit with storage charging system in the secondary circuit	Drinking water heating without control valve in priority circuit
3	Three heating circuits, indirect connection	Third heating circuit without control valve
4	One heating circuit, indirect connection, one drinking water heating circuit with storage charging system in the secondary circuit	
5	Two heating circuits, indirect connection, one drinking water heating circuit with storage charging system in the secondary circuit	Second heating circuit without control valve
6	Three heating circuits, direct connection	
7	One heating circuit, indirect connection, one drinking water heating circuit with storage charging system in the primary circuit	
8	Two heating circuits, indirect connection, one drinking water heating circuit with storage charging system in the primary circuit	Second heating circuit without control valve
9	Two heating circuits, direct connection, one drinking water heating circuit with storage charging system	

Technical data

Inputs	Depending on system code no. selected (see above)
Sensor inputs	Max. 13 configurable inputs for temperature sensors (Pt100 and PTC or Pt100 and Pt1000 or Pt100 and NTC) or binary signals (heating/hot water circuit) 5 flow temperature sensors 2 room temperature sensors 2 outdoor temperature sensors 2 return flow temperature sensors 2 storage temperature sensors
Binary inputs	Storage thermostat
Further inputs	Analog input 0 to 10 V ($R_i = 18 \text{ k}\Omega$) Pulse-counting input for volume flow limitation, current input 4(0) to 20 mA for outdoor temperature, Inputs for position indication, remote control for correction of room temperature and selection of operating mode
Outputs	Depending on system code no. selected (see above)
Control signal y	Three-step signals: max. load 250 V~, 3 A On-off signal: max. load 250 V~, 3 A
Analog output	0 to 10 V (load > 4.7 k Ω)
Binary outputs	5 outputs for pump control Max. load: 250 V~, 3 A 4 transistor outputs for control of the rotational speed of circulation pumps
Interfaces	RS 485 for connection to four-wire bus or RS 232 for connection to modem
Optional	Interface for meter bus
Power supply	230 V, 48 to 62 Hz, power 3 VA
Ambient temperature	0 to 40 °C (storage -20 to 60 °C)
Degree of protection	IP 40 according to IEC 529
Class of protection	I according to VDE 0106
Degree of contamination	2 according to VDE 0110
Overvoltage category	II according to VDE 0110
Humidity rating	F according to VDE 40040
Noise immunity	According to EN 50082 Part 1
Noise emission	According to EN 50081 Part 1

Dimensions in mm

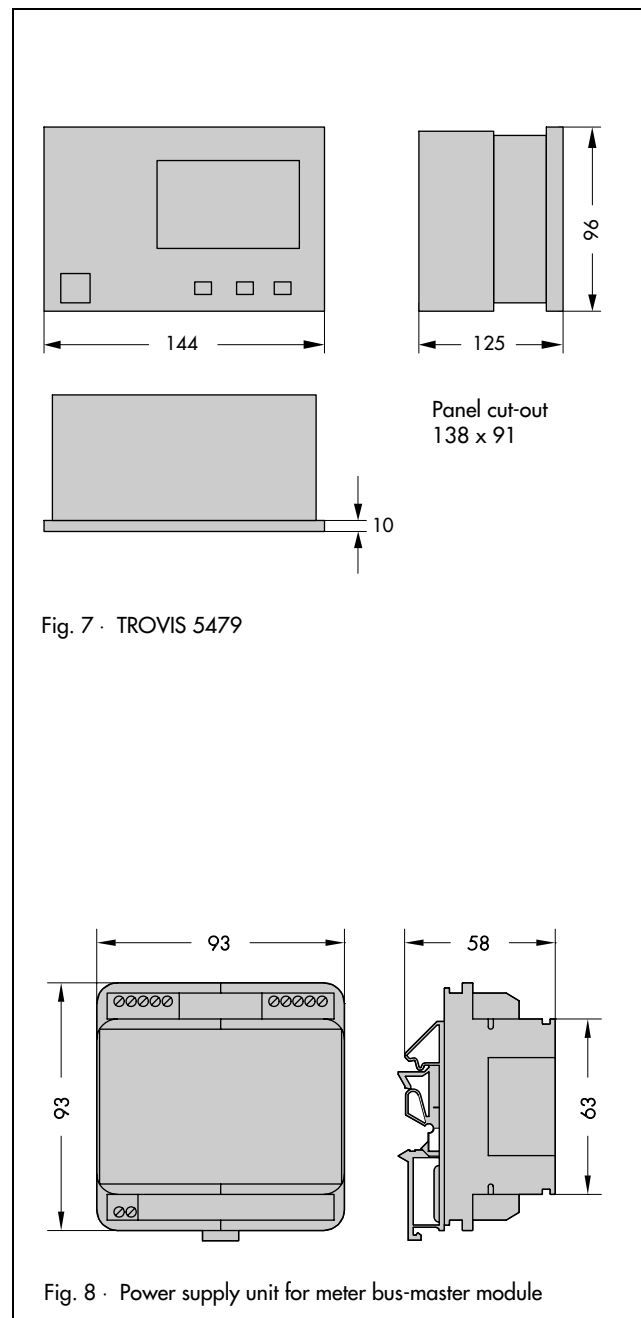

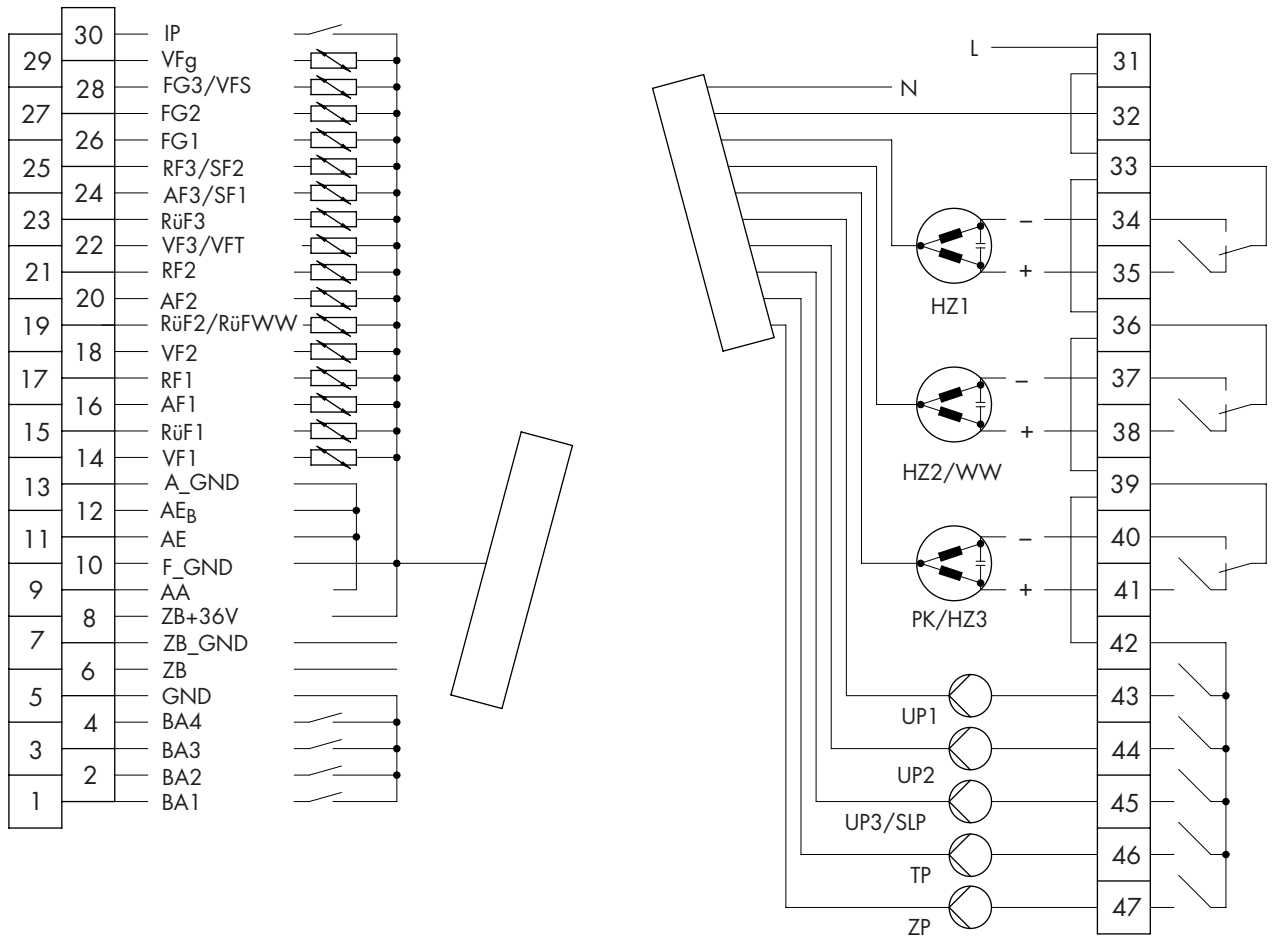

- | | | | |
|--------------|---|------------|--|
| A_GND | Shared analog ground | RüFWW | Return flow temperature for drinking water heating |
| AA | Analog output | SF1 | Storage sensor On |
| AE | Analog input | SF2 | Storage sensor Off |
| AEB | Analog input for external connection of heat demand | SLP | Storage charging pump |
| AF1 to AF3 | Outdoor temperature sensor for control loops 1 to 3 | TP | Heat exchanger charging pump |
| BA1 to BA4 | Binary output 1 to 4 | UP1 to UP3 | Circulation pumps in heating circuits 1 to 3 |
| F_GND | Shared sensor ground | VF1 to VF3 | Flow temperature in heating circuits 1 to 3 |
| FG1 to FG3 | Potentiometer for control loops 1 to 3 | VFg | Flow temperature sensor in the primary circuit |
| GND | Shared ground | VFS | Flow temperature sensor of storage tank |
| HZ1 to HZ3 | Control valve heating circuit 1 to 3 | VFT | Flow temperature sensor of heat exchanger |
| IP | Pulse-counting input | WW | Control valve in drinking water heating circuit |
| PK | Control valve primary circuit | ZB | Meter bus |
| RF1 to RF3 | Room temperature sensor for control loops 1 to 3 | ZB_GND | Meter bus ground |
| RüF1 to RüF3 | Room temperature sensor for control loops 1 to 3 | ZP | Circulation pump |

The Fig. above shows the maximum possible equipment. The input and output assignments vary with the respective system code number.

Fig. 9 · Terminal assignment for TROVIS 5479

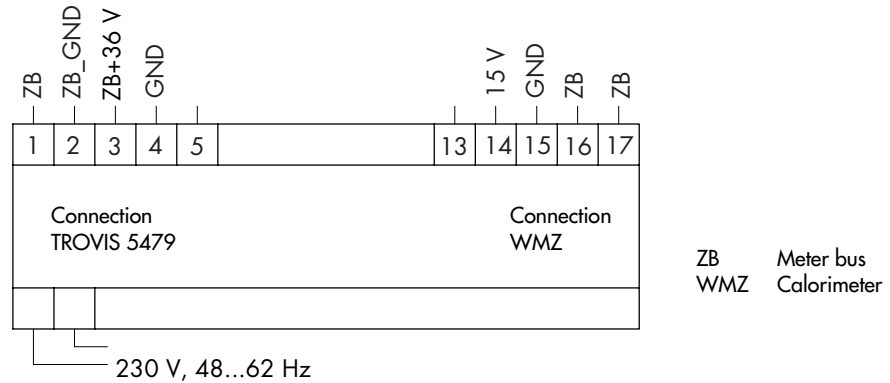

Fig. 10 · Terminal assignment at the power supply unit for the meter bus-master module

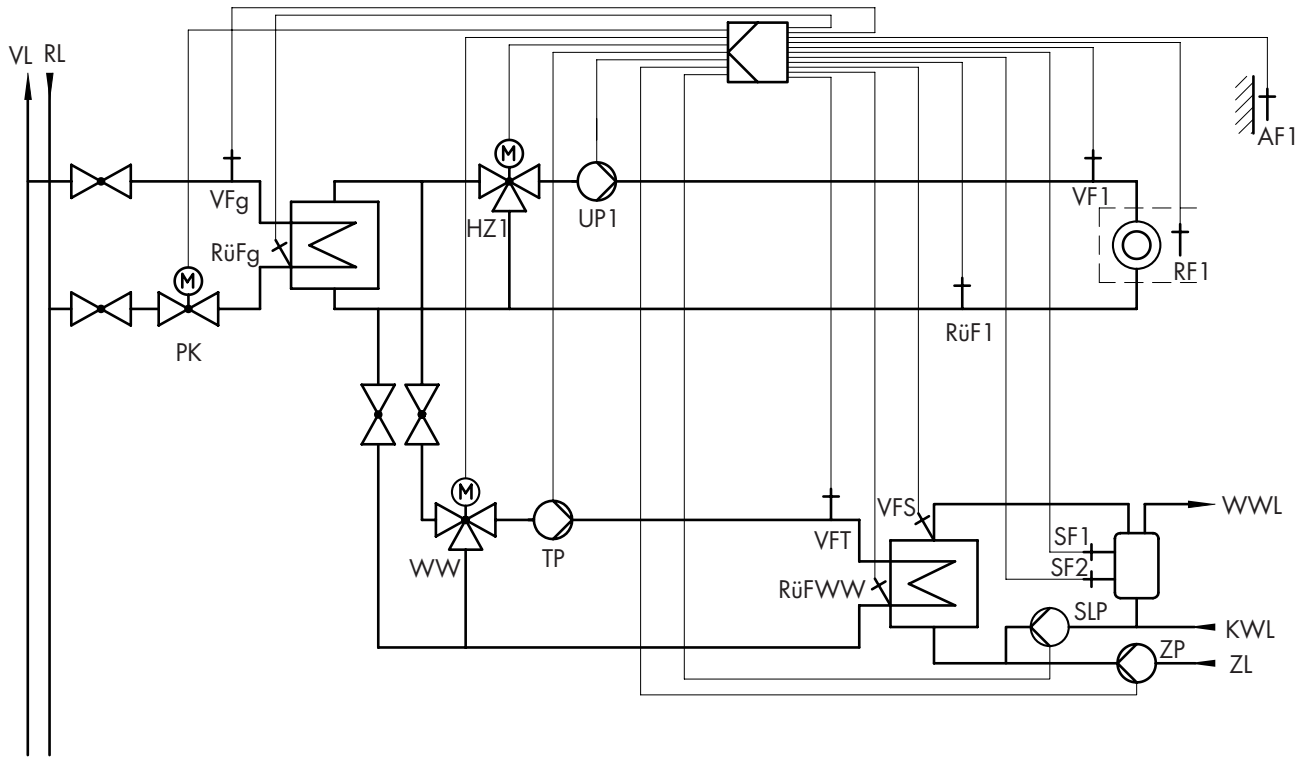

Fig. 11 · System code no. 4

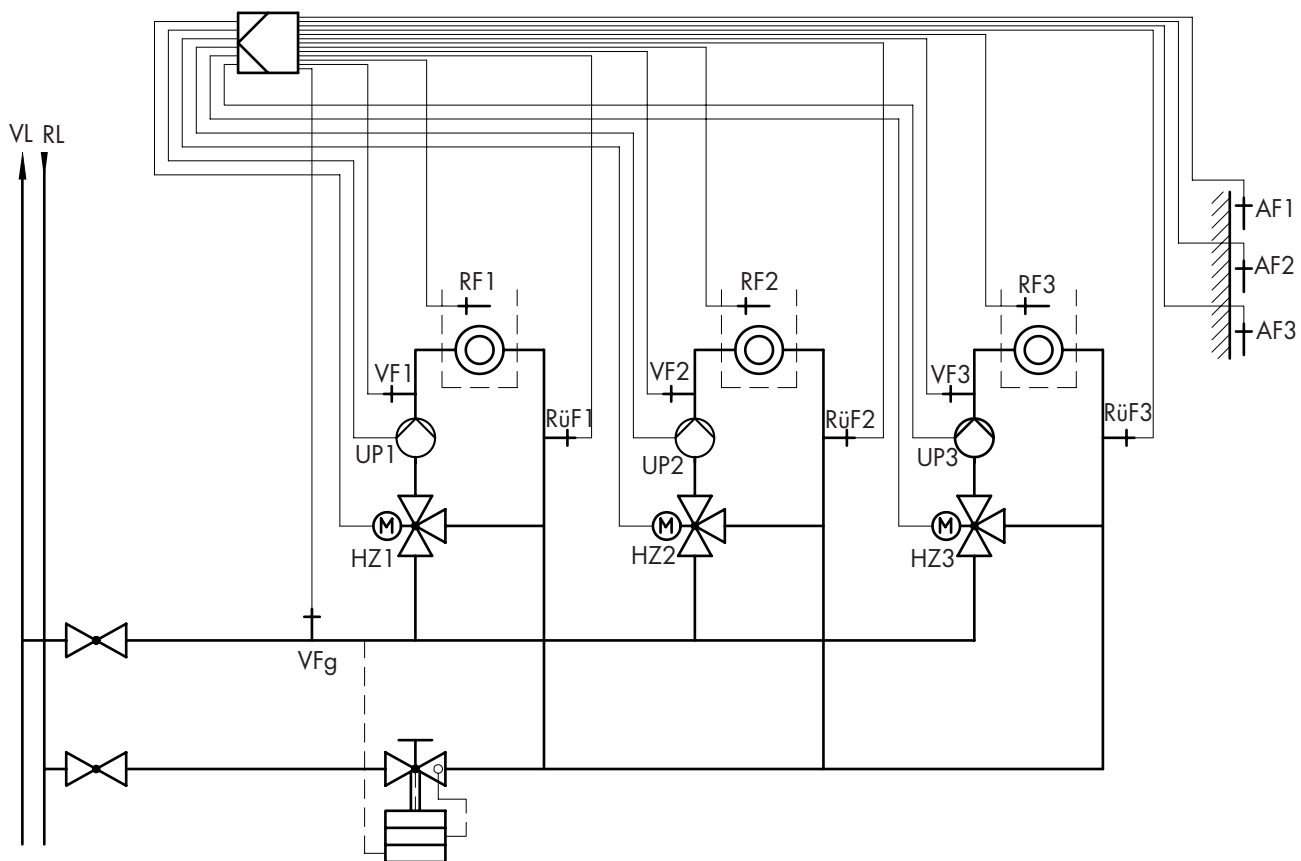

Fig. 12 · System code number 6

Weight	Approx. 0.6 kg
---------------	----------------

VL Flow line
 RL Return flow line
 WWL Hot water pipe

KL Cold water pipe
 ZL Circulation pipe
 For other abbreviations, see Fig. 9



SAMSON AG · MESS- UND REGELTECHNIK
 Weismüllerstraße 3 · 60314 Frankfurt am Main · Germany
 Phone: +49 69 4009-0 · Fax: +49 69 4009-1507
 Internet: <http://www.samson.de>

T 5479 EN