

TROVIS 5757-3 Electric Actuator with Process Controller

for domestic hot water heating



Application

Electric actuator with integrated digital controller used to position force-locking valves in nominal sizes DN 15 to 25. Domestic hot water heating control in instantaneous heating systems used in small to medium-sized buildings connected to a district heating or local heat supply network.



The TROVIS 5757-3 is a combination of an electric actuator and an integrated digital controller. It is especially designed for DHW heating in instantaneous heating systems for small to medium-sized buildings. It is particularly suitable for mounting to SAMSON Types 3222, 3222 N, 2488 and 3267 Valves as well as to special versions of Type 3226 and Type 3260 Valves.

Special features

- Control using two different set points, e.g. DHW temperature and DHW temperature for thermal disinfection. A binary input is used to switch between the set points.
- Function to maintain water temperature constant, preventing the heat exchanger from cooling down between tapping
- Direction of action reversible
 - Globe valve opens when the actuator stem retracts (increasing/increasing)
 - Three-way mixing valve mixes/diverts the flow(s) when the actuator stem extends (increasing/decreasing)
- Limit value monitoring:
 - The valve is closed by the actuator when the maximum adjustable limit is exceeded
 - The frost protection function is started when the temperature falls below the minimum adjustable limit
- Configuration, parameterization, diagnostic function and direct connection for monitoring using the TROVIS-VIEW software
 - Direct data transmission using a connecting cable (direct connection to computer)
 - Data transmission over a memory pen
- Maintenance-free
- Special valve version available for small tapping amounts



Fig. 1: TROVIS 5757-3 Electric Actuator with Process Controller

Accessories

- TROVIS-VIEW configuration software for TROVIS 5757-3 Electric Actuator with Process Controller
- Hardware package with a memory pen-64, a connecting cable and a modular adapter (order no. 1400-9998)
- Memory pen-64 (order no. 1400-9753)
- Type 5207-0060 Pt 1000 Sensor
- Sensor pocket (order no. 1400-9249)
- Water flow sensor with extension cable with mating connector (order no. 1400-9246)

Note: Details on Type 3222, Type 3222 N, Type 3267, Type 3226 and Type 3260 Valves can be found in the Data Sheets ▶ T 5866, ▶ T 5867, ▶ T 5894, ▶ T 5863 and ▶ T 5861.

Principle of operation (Fig. 2)

The actuator consists of a digital controller which is integrated into the electric actuator housing.

The digital controller is connected to a temperature sensor on the input side which can be optionally upgraded by a water flow sensor or a flow switch.

In addition to the temperature sensor input, the actuator has a 0/4 to 20 mA current input. This can be used either instead of the temperature sensor or to connect an external reference variable.

The set points W1 and W2 of the digital controller are set to 60 °C and 70 °C respectively and can be changed like all other settings with the help of the TROVIS-VIEW configuration software.

The output signal of the digital controller functions as a three-step signal on the synchronous motor of the actuator and is transferred over the connected gear to the actuator stem (3) and used as the positioning force

The motor is switched off by torque-dependent switches when an end position is reached or in case the motor is overloaded.

The actuator is mounted onto the valve using a coupling nut (4).

When the actuator stem extends, the valve is closed, opposing the force of the valve spring (7). When the actuator stem retracts, the valve is opened as the plug stem (6) follows the motion of the return spring.

The valve can be moved to any position in the de-energized state by the handwheel (2). Travel and direction of action can be read off the travel indicator (5) on the side of the actuator housing.

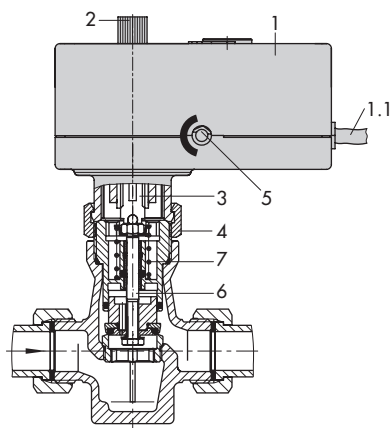

- | | | | |
|-----|---|---|------------------|
| 1 | Electric actuator with process controller | 5 | Travel indicator |
| 1.1 | Cable entry | 6 | Plug stem |
| 2 | Handwheel | 7 | Valve spring |
| 3 | Actuator stem | 8 | Serial interface |
| 4 | Coupling nut | | |

Fig. 2: Functional diagram

Electrical equipment

The actuator requires a Pt 1000 temperature sensor (e.g. Type 5207-0060) to be connected for it to function. The fast-response Pt 1000 sensor allows the temperature to be controlled to the corresponding set point almost immediately. Two set points W1 and W2 can be used. A binary input is used to switch between the set points.

The use of the Type 5207-0060 Pt 1000 Sensor is recommended in conjunction with a sensor pocket to provide optimal positioning of the temperature sensor at the heat exchanger. The 0/4 to 20 mA current input can be used in place of the Pt 1000 sensor for control purposes or as the reference variable.

In addition, a water flow sensor or a flow switch can be connected to quickly recognize when hot water is being tapped or to improve the control accuracy even further. Fig. 5 shows a sample application.

For versions with a **switching output**, this output can be configured as either a pump output (circulation pump for the DHW circuit or heating circuit), a fault alarm output or an output to report when hot water is tapped.

Installation

Before mounting the actuator on the valve, retract the actuator stem. Hold the actuator stem in this position, while tightening the coupling nut.

Any mounting position may be used, however, the actuator may not be installed in a suspended position.

Note for operation without circulation pipe

The heat exchanger should be installed in a horizontal position with the connections at the side to protect the hot water system against hot water accumulation when operated from standstill and to prevent limescale in the heat exchanger.

First consult the heat exchanger manufacturer concerning this mounting position and the intended effect.

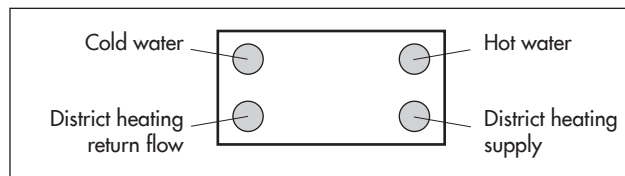

Note on tapping small amounts of hot water

A special version of Type 3222/5757-3 (DN 25, $K_{VS} = 2.5$, with Type 3222 N $K_{VS} = 2$) with a special plug design is available for small installations (apartment or house). As a result, even small tapping amounts can be controlled optimally.

Electrical connection

Two cables, cable ends with wire end ferrules

Any wires that are not used need to be insulated.

Ordering text

TROVIS 5757-3 Electric Actuator with Process Controller

Digital controller settings

The digital controller settings can be changed in the TROVIS-VIEW Configuration and Operator Interface.

Configuration	Default setting
F 01 – DHW tapping recognition 0: Continuous control 1: Flow rate sensor active	1
F 02 – Flow rate sensor 0: Flow switch 1: Water flow sensor	1
F 03 – Adaptation 0: Not active 1: Active (with water flow sensor)	1
F 04 – Direction of action 0: >> (increasing/increasing) 1: <> (increasing/decreasing)	0
F 05 – Current input 0: Not active (binary input) 1: Active	0
F 06 – Function of current input 0: Actual value 1: Set point	0
F 07 – Measuring range of current input 0: 0 to 20 mA 1: 4 to 20 mA	0
F 08 – Function of binary input 0: Termination of maintaining heat exchanger at constant temperature 1: Switchover between internal set points	0
F 09 – Maintain heat exchanger at constant temperature 0: Time adjustable 1: Continuous	0
F 10 – Upper limit (GWH) 0: No limitation 1: Exceeding GWH causes switch-off	0
F 11 – Lower limit (GWL) 0: No frost protection 1: GWL starts frost protection	0
F 16 – Function of switching output 1: Not active 2: Fault alarm 3: Circulation pump (DHW) 4: Circulation pump (heating) 5: Tapping 6: Circulation pump (heating) reversed	1
F 17 – Pump protection 0: No 1: Yes	1

Parameters	Default setting
P 01 – Set point W1 0.0 to 100.0 °C	60.0 °C
P 02 – Set point W2 0.0 to 100.0 °C	70.0 °C
P 03 – Lower measuring range value Xmin –50.0 to 90.0 °C	0.0 °C
P 04 – Upper measuring range value Xmax 10.0 to 150.0 °C	100.0 °C
P 05 – Upper limit (GWH) 0.0 to 100.0 °C	95.0 °C
P 06 – Lower limit (GWL) 0.0 to 20.0 °C	5.0 °C
P 07 – Proportional-action coefficient Kp 0.1 to 50.0	0.8
P 08 – Reset time Tn 0 to 999 s	15 s
P 09 – Derivative-action time Tv 0 to 999 s	0 s
P 10 – Actuator transit time Ty 10 to 240 s	25 s
P 11 – Set-back difference 0 to 30 K	8 K
P 12 – Heating period to maintain heat exchanger at constant temperature 0 to 25.5 h	24 h

Technical data · Electric actuator with process controller

TROVIS 5757-3 Actuator	
Connection to valve	Force-locking
Rated travel	6 mm
Transit time for rated travel	20 s
Thrust	300 N
Power supply	230 V ($\pm 10\%$)/50 Hz
Power consumption	Approx. 4 VA
Class of protection	II
Manual override	Yes
Permissible temperatures ¹⁾	
Ambient	0 to 50 °C
Storage	-20 to 70 °C
Degree of protection	IP 42
Installation	Any position except suspended
Electromagnetic compatibility	According to EN 61000-6-2, EN 61000-6-3 and EN 61326
Weight	Approx. 0.7 kg
Binary input BI1 ²⁾	Set point switchover
Binary input BI2 ²⁾	Flow switch
Control input	0/4 to 20 mA
Version with switching output	
Switching output	230 V/50 Hz, 1 A
Compliance	
Accessories	
Temperature sensor	Pt 1000: -50 to 150 °C
Water flow sensor	530 pulses/l
Flow switch	Floating contact

¹⁾ The permissible medium temperature depends on the valve on which the electric actuator is mounted. The limits specified in the valve documentation apply.

²⁾ Recommendation: use devices with gold contacts when using relays

Technical data · Accessories

Type 5207-0060 Pt 1000 Sensor	
Optimized temperature sensor with fast response which is simple to install	
Electrical connection	Wire ends fitted with wire end ferrules including plastic sleeves
Connecting cable	PVC, 2000 mm long
Perm. ambient temperature	-5 to 80 °C
Perm. medium temperature	-5 to 90 °C
Mechanical connection	Stainless steel (1.4404)
Protective tubing	Stainless steel (1.4404)
Time response	$t_{0,5} < 1\text{ s} \cdot t_{0,9} < 3\text{ s}$, 0.4 m/s in water
Thread length	52 mm
Nominal pressure	PN 16
Sensor pocket (1400-9249)	
For Type 5207-0060 Pt 1000 Sensor for mounting to heat exchangers for optimal positioning instantaneous heating systems	
Material	Red brass CC491K (2.1096.01)
Mechanical connection	Male thread G $\frac{3}{4}$ Female thread G $\frac{1}{4}$ Coupling nut G $\frac{3}{4}$
Nominal pressure	PN 16
Water flow sensor with extension cable (order no. 1400-9246)	
Axial turbine flowmeter for liquids	
Measuring range	1 to 30 l/min
Measuring accuracy	1 % of upper measuring range value
Mechanical connection	G $\frac{3}{4}$ male thread
Nominal size	DN 10
Nominal pressure	PN 10
Max. medium temperature	70 °C, briefly 90 °C
Power supply	4.5 to 24 V DC
Degree of protection	IP 54 according to EN 60529
Electrical connection	3 single wires with connector (JST) approx. 150 mm long
Sensor	Hall effect sensor
Pressure loss	0.25 bar at 15 l/min
Pipe socket/vane wheel	PPO Noryl

Electrical connection

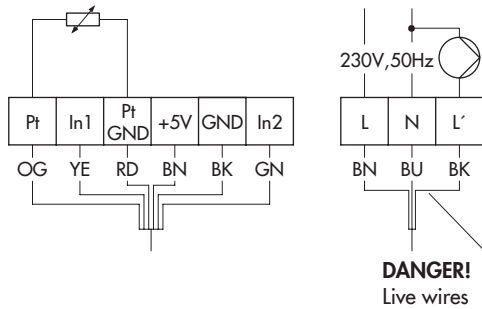

Operation with Pt 1000 sensor
(switching output L' as pump output)

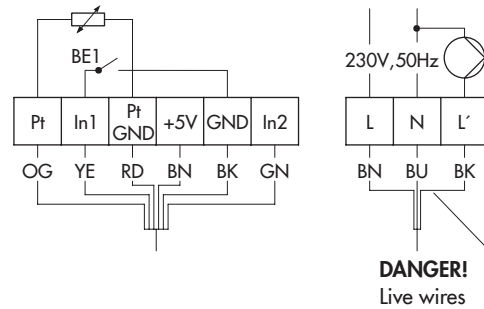

Operation with Pt 1000 sensor and binary contact to determine the set point
(switching output L' as pump output)

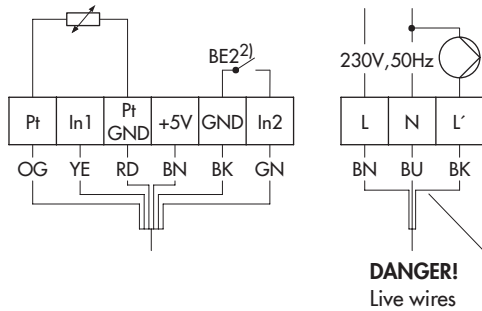

Operation with Pt 1000 sensor and flow switch
(switching output L' as pump output)

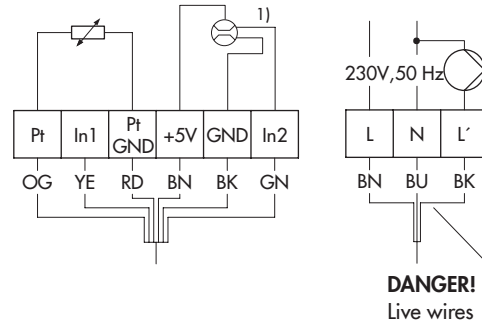

Operation with Pt 1000 sensor and water flow sensor
(switching output L' as pump output)
Information for connection of water flow sensor, see Fig. 4

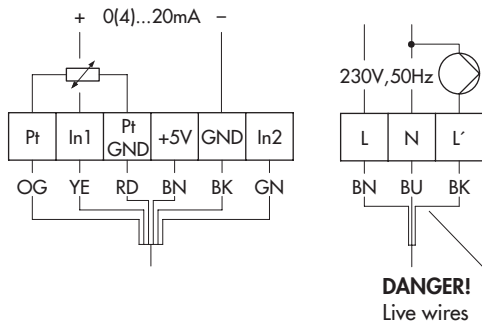

Operation with Pt 1000 sensor and set point guided by current input
(switching output L' as pump output)

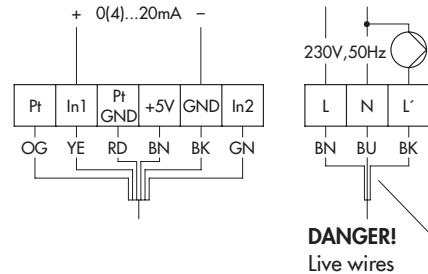

Operation with current input (actual value)
(switching output L' as pump output)

- 1) Water flow sensor (WSS)
- 2) Flow switch

OG orange
YE yellow
RD red
BN brown
GN green
BK black
BU blue

Note: The switching output L' can be configured as a pump output, a fault alarm output or as an output to report when hot water is tapped.

Fig. 3: Electrical connection of various applications

Information on connection of water flow sensor

Connection of water flow sensor (WWS)

WSS	Extension cable	TROVIS 5757-3
GND BK	BN	BK GND
Signal GN	GN	GN Signal
5 V WH	WH	BN 5 V

BN brown
GN green
BK black
WH white

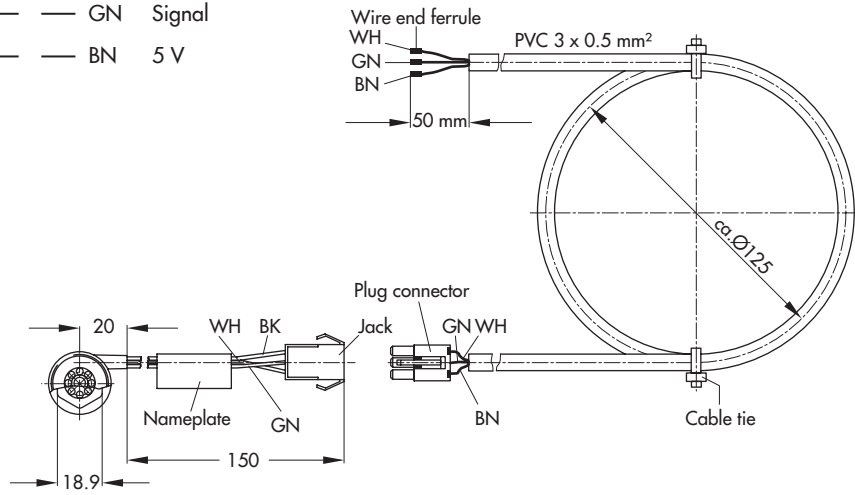

Fig. 4: Connection of water flow sensor (WWS)

Sample application

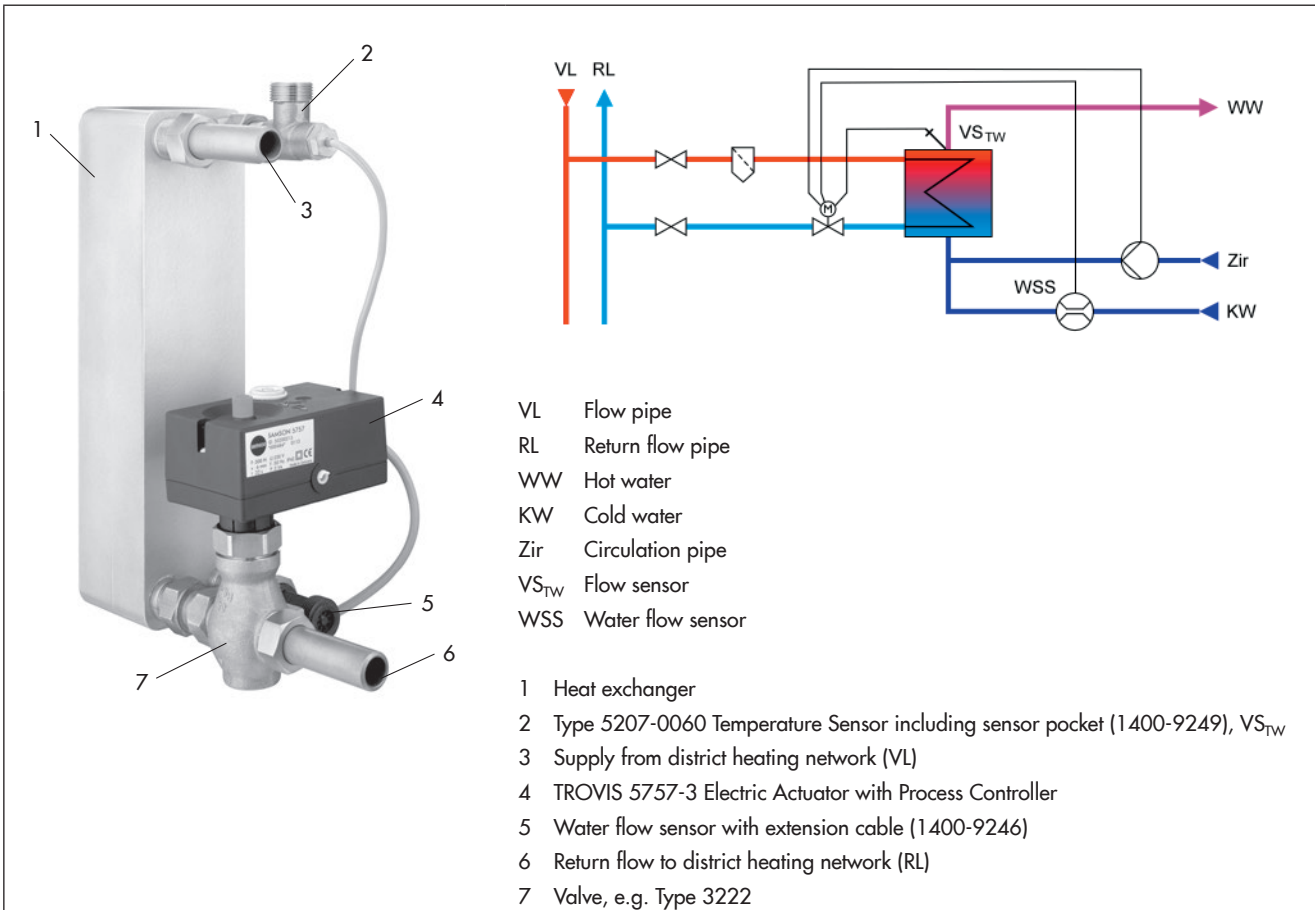
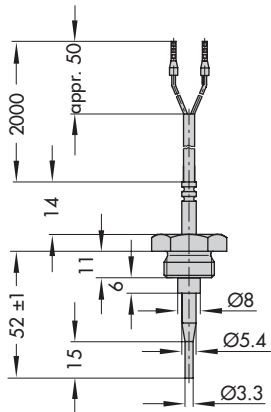
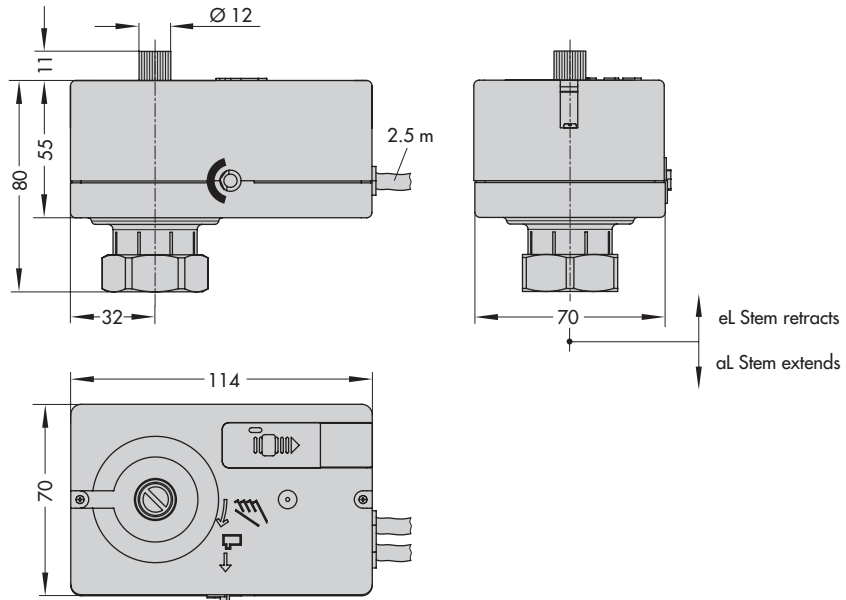
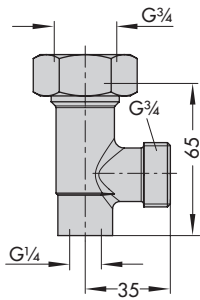

Fig. 5: Sample application: TROVIS 5757-3 with Type 5207-0060 Pt 1000 Sensor including sensor pocket and water flow sensor

Dimensions in mm



Type 5207-0060 Temperature Sensor (Pt 1000) (configuration ID 3514819)



Sensor pocket (including gasket) for heat exchanger with G 3/4 (order no. 1400-9249)

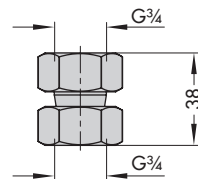

Connecting piece (including gasket) for valve G 3/4 (order no. 1400-9236)

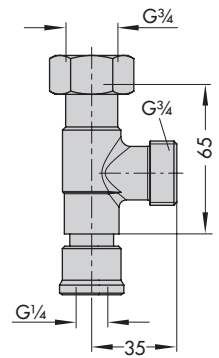

Circulation pipe connection (including gasket) (order no. 1400-9232)

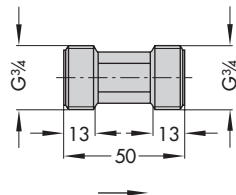

Water flow sensor with extension cable (order no. 1400-9246)

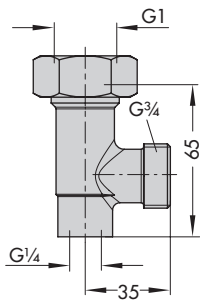

Sensor pocket (including gasket) for heat exchanger with G 1 (order no. 1400-9252)

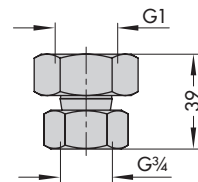

Connecting piece (including gasket) for valve G 1 (order no. 1400-9237)

Specifications subject to change without notice



SAMSON AG · MESS- UND REGELTECHNIK
Weismüllerstraße 3 · 60314 Frankfurt am Main, Germany
Phone: +49 69 4009-0 · Fax: +49 69 4009-1507
samson@samson.de · www.samson.de

T 5757 EN

2017-04-26 · English