

Electric Actuators



Type 5821 (without fail-safe action)

Type 5822 (with fail-safe action)

Application

Electric actuators designed for control valves used in heating, ventilation and air-conditioning systems. Form-fit or force-locking mechanical connection between the actuator stem and the valve stem.



Type 5821 and Type 5822 Electric Actuators are available in two versions, with form-fit connection between the actuator stem and the valve plug stem or with force-locking connection (see section "versions"). Another physical difference between the two electric actuators mentioned is the manner in which they are attached to the valve body. They are not compatible.

The actuators are of the linear type.

Type 5821 Electric Actuators come without fail-safe action, Type 5822 Electric Actuators are equipped with fail-safe action.

Type 5821 is equipped with a handwheel.

For optionally available equipment, refer to Table Technical data.

Versions without fail-safe action

Electric actuator		Type 5821-		<input type="checkbox"/>
Travel [mm]	Transit time [s]	Closing force [N]		
Form-fit version				
7.5	90	600		1
15	90	300		2
7.5	40	300		3
Force-locking version				
7.5	90	600		5
7.5	40	300		6

Versions with fail-safe action

Electric actuator		Type 5822-		<input type="checkbox"/>	<input type="checkbox"/>
		Travel [mm]	Transit time [s]	Closing force [N]	
Form-fit version					
Operating direction of the fail-safe action	"Out"	7.5	90	280	1 0
		15	90	170	2 0
		7.5	40	170	4 0
	"In"	7.5	90	280	1 1
		15	90	170	2 1
		7.5	40	170	4 1
Force-locking version					
"Out"	7.5	90	420 ¹⁾	6 0	
	7.5	40	280	7 0	

¹⁾ Special version for valves with a minimum reset force of 140 N, e.g. Type 3213 and Type 3214 Globe Valve.



Fig. 1 - Type 5821-1/-2/-3 Electric Actuator, form-fit version

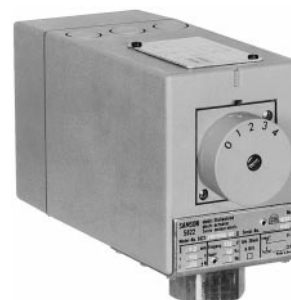

Fig. 2 - Type 5822-60/-70 Electric Actuator, force-locking version

Principle of operation

The force of the actuator motor is transmitted to the connecting rod (5) or actuator stem (4) via gear reduction and crankshaft. With form-fit actuator versions, the connecting rod is mechanically connected to the plug stem (20.1) of the control valve. In the other version, the actuator stem presses the plug stem in the closing direction of the valve. Movement in the opposite direction is caused by a spring in the valve.

When the final positions are reached, or when the valve is blocked, the motor is disconnected via the torque switches set at the factory. In addition, two additional travel-dependent overridable switches can be installed and used to indicate the final positions. Wirkungsweise

Type 5821 (Figs. 4 and 5)

This actuator without fail-safe action contains instead a handwheel (3) for manual adjustment. When the release button (2) is simultaneously pressed, the clutch between the gear reduction and motor is released, and the valve can be manually moved in the desired position. The travel position is indicated on a scale.

Type 5822 (Fig. 6)

Actuators incorporating fail-safe action largely correspond to Type 5821. However, they contain a spring assembly (4.1) and an electromagnet. With these actuators, a cover plate replaces the handwheel (3).

The electromagnet which can be connected in a safety interlock circuit, disengages the clutch between the gear reduction and motor in de-energized state, thus releasing the spring assembly. As a result, the actuator stem moves in the appropriate fail-safe position.

For typetested actuators, only fail-safe action "Out" (plug stem (20.1) retracting) is permitted. – For the form-fit model, fail-safe action "In" is also technically possible.

Register number

Type 5822 Electric Actuators have been typetested in combination with various control valves by the German Technical Inspectorate (TÜV) according to DIN 32 730.

Register number available upon request.

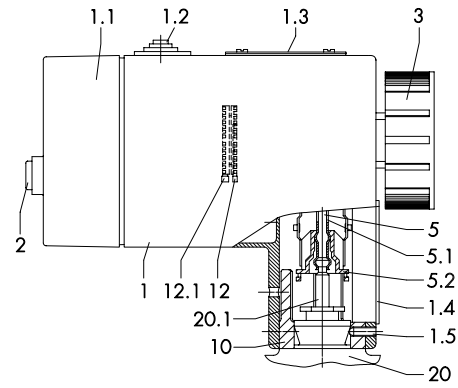

Fig. 4 · Type 5821-1/-2/-3 Electric Actuator

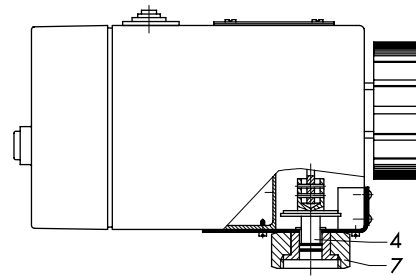

Fig. 5 · Type 5821-5/-6 Electric Actuator

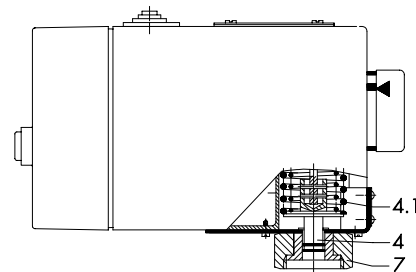

Fig. 6 · Type 5822-60/-70 Electric Actuator with fail-safe position "Out"

Legend for Figs. 4 to 6

1 Case	5 Connecting rod without spring assembly, for Type 5821-1/-2/-3 Electric Actuator only
1.1 Case lid	5.1 Connecting clamp
1.2 Cable entry	5.2 Clamping ring
1.3 Cover plate	7 Coupling nut
1.4 Name plate	10 Connecting sleeve
1.5 Threaded pin	12 Switch
2 Release button	12.1 Cam disk
3 Handwheel	20 Valve body
4 Actuator stem	20.1 Plug stem
4.1 Spring assembly for force-locking version	

Table 1 · Technical data relating to electric actuators (see section "Versions" for details)

Actuator	form-fit force-locking	Type	5821-1	5821-2	5821-3	5822-10	5822-11	5822-20	5822-21		5822-40		5822-41
			5821-5		5821-6						5822-60		5822-70
Fail-safe action			Without				With						
Operating direction			-			OUT	IN	OUT	IN	OUT	OUT	OUT	IN
Rated travel		mm	7.5	15	7.5	7.5		15		7.5	7.5	7.5	7.5
Transit time for rated travel		s	90	90	40	90		90		90	40	40	40
Transit time in case of failure		s	-			8		8		8	5	5	5
Nominal thrust		N	600	300	300	320		130					
Nominal closing force of the return spring		N	-			280		170		420	170	280	170
Power supply			230, 110 or 24 V, 50 to 60 Hz			230, 110 or 24 V, 50 or 60 Hz							
Power consumption			Actuator motor: 4 VA										
			-			Electromagnet: 5 VA							
Perm. ambient temperature			0 to +50 °C										
Perm. storage temperature			-20 to +70 °C										
Perm. temperature at connecting point			0 to +110 °C ²⁾										
Degree of protection			IP 44 (at vertical installation)										
Weight		appr. kg	1.3				1.5						
Additional electrical equipment													
Switches			Two separately adjustable limit contacts										
Permissible load			AC voltage: 24 to 250 V, 3 A; DC voltage: 24 V, 3 A										
Potentiometer			0 to 1000 Ω (approx. 870 Ω at rated travel), permissible load: 0.5 W ¹⁾										
Electric positioner			Only for power supply 24 V AC and version with potentiometer										
Control signal			4 to 20 mA, 0 to 20 mA, 0 to 10 VDC										
Split-range operation			4 to 12 and 12 to 20 mA, 0 to 10 and 10 to 20 mA, 0 to 5 and 5 to 10 V DC										

1) Other values upon request

2) For higher temperatures, connect an insulating section or yoke

Additional electrical equipment

The actuators can be optionally equipped with the following electrical accessories.

Electric switches

The actuators can be optionally fitted with two overridable electric switches which are controlled via cam disks positioned on the actuator shaft of the gear reduction. The cam disks can be externally adjusted after removing the cover plate (1.3).

Potentiometer

The potentiometer is coupled to the gear reduction. Rated travels of 7.5 and 15 mm produce a change of resistance from 0 to 87 % of the nominal value of, e.g. 1000 ohm. For valves with 5 mm travel, special values of resistance are used.

Electric positioner

Positioners ensure a preselected correspondence between valve position and control signal. They compare the standardized output signal of electrical control equipment (4 to 20 mA, 0 to 20 mA or 0 to 10 V DC) with the potentiometer's output value which is proportional to the travel, and generate a three-step control signal as output variable. Zero and range are adjustable in wide limits. Therefore, they are also applicable for split-range operation.

Table 2 · Materials

Case, lid	Polyamide, reinforced with glass
Connecting sleeve/nut	Brass
Handwheel	Plastic material (ABS)
Crankshaft	GD-Zn Al 4
Connecting clamp	Spring steel C60

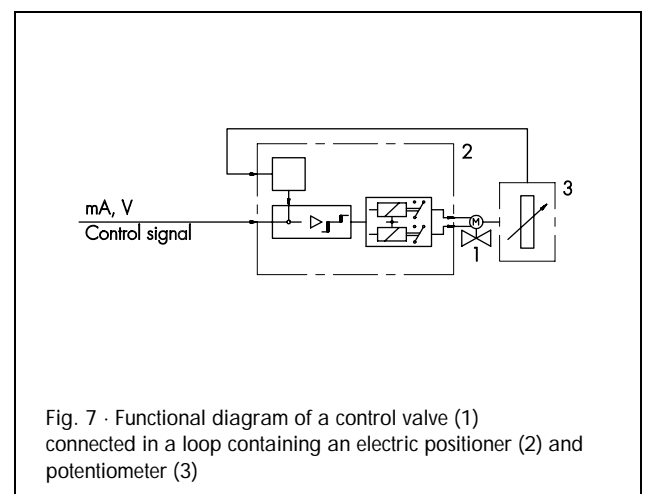

Fig. 7 · Functional diagram of a control valve (1) connected in a loop containing an electric positioner (2) and potentiometer (3)

Electrical connection

Fig. 8 illustrates the connection diagram of actuators operating without a positioner. The controller output signals are connected to terminals L1 and L2. If voltage is applied to terminal L2, the actuator motor moves the actuator stem (4) or connecting rod (5) in the operating direction "IN" (into the actuator). If, in comparison, a control signal is applied to terminal L1, the connecting rod or actuator stem is moved in the operating direction "OUT".

The circuit diagram for versions incorporating electric positioners is depicted in Fig. 9. Control signals from 4 to 20 mA or 0 to 20 mA are connected to terminals 11 and 12, control signals from 0 to 10 V to terminals 12 and 13. The operating direction of the control signal can be adjusted on the positioner.

Ordering text

Type 5821-... /5822-... Electric Actuator

Nominal closing force ... N

Form-fit/force-locking linkage

Without/with fail-safe action, operating direction "OUT"/"IN"

Valve travel ... mm

Power supply: 230 V /110 V /24 V; frequency 50 Hz/60 Hz

Options: Two switches/

Potentiometer 0 to ... Ω /

Electric positioner

Note

Type 5802 Electric Actuators with positioning forces up to 1800 N, see Data Sheet T 5801 EN.

Type 3274 Electrohydraulic Actuators (partially typetested) with positioning forces up to 7700 N, see Data Sheet T 8340 EN.

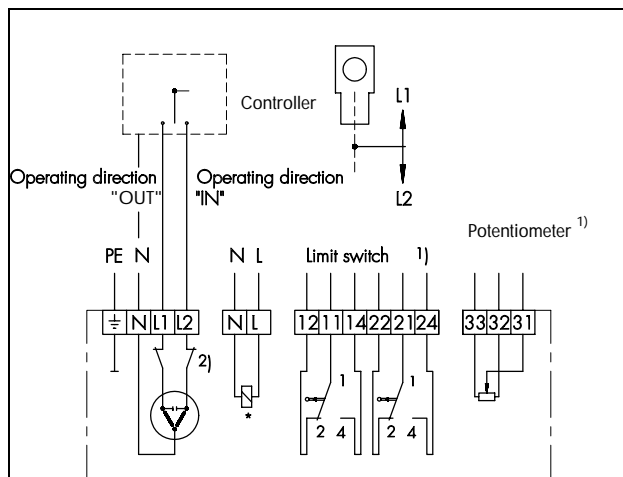

Fig. 8 · Circuit diagram for actuators without positioner

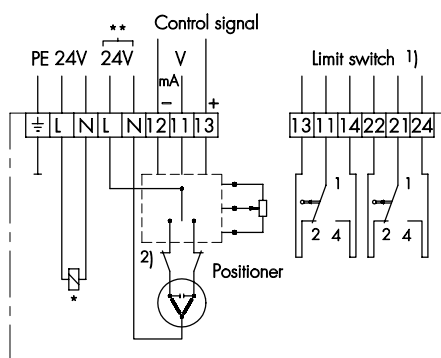

Fig. 9 · Circuit diagram for actuators with positioner

* Electromagnet for connection in a safety interlock circuit, only for actuators incorporating fail-safe action (Type 5822).

** Note:

If several actuators are interconnected, e.g. in split-range operation, note that terminal N must always be connected to terminal N, and terminal L must always be connected to terminal L.

1) Additional switches or potentiometer

2) Function-related motor limit switches

Dimensions in mm

Type 5821-1/-2/-3 and Type 5822-10/-20/-40/-11/-21/-41 Electric Actuators

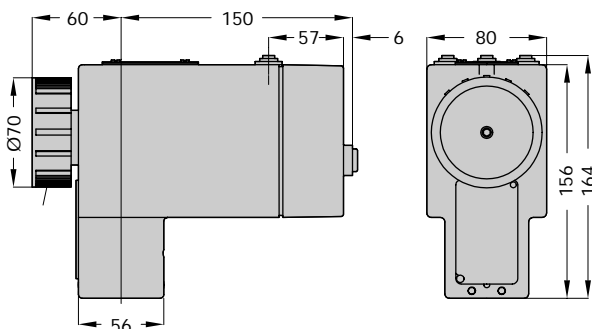

Type 5821-5/-6 and Type 5822-60/-70 Electric Actuators

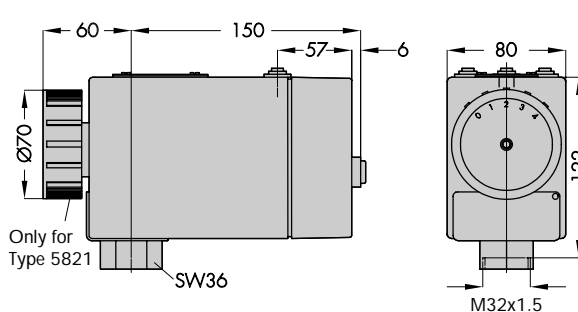

Specifications subject to change without notice.



SAMSON AG · MESS- UND REGELTECHNIK
Weismüllerstraße 3 · D-60314 Frankfurt am Main
Postfach 10 19 01 · D-60019 Frankfurt am Main
Telefon (069) 4 00 90 · Telefax (069) 4 00 95 07

T 5822 EN