

Pneumatic Actuators



Type 2780-1

Type 2780-2

Application

Versatile actuators for use in heating, ventilation and air-conditioning systems as well as for mechanical engineering. Effective diaphragm area 120 cm², rated travel 6, 12 or 15 mm

The Type 2780 Pneumatic Actuators are diaphragm-type actuators with internal compression springs. They are suitable for attachment to SAMSON Type 3213 and Type 3222 Globe Valves and to Type 3226 and Type 3260 Three-way Valves.

Special features

- Diaphragm cases made of die-cast aluminum
- Actuator action easy to reverse
- Direct attachment of a positioner to the Type 2780-2 Actuator, therefore no external piping is required, regardless of the operating direction of the actuator and the positioner.

Versions

Type 2780-1 (Fig. 1) · Pneumatic Actuator

Type 2780-2 (Fig. 2) · Pneumatic Actuator for direct attachment of a positioner

Ordering text

Actuator Type 2780-1/-2

Actuator action: Actuator stem extends/retracts

Rated travel 6/12/15 mm

Bench range ... bar

Loading pressure connection G $\frac{1}{8}$ / NPT $\frac{1}{8}$



Fig. 1 · Type 2780-1 Actuator



Fig. 2 · Type 2780-2 Actuator

Principle of operation

The pneumatic actuator is operated by the forces acting on the diaphragm. The actuator spring force acts from the one side and the force of the loading pressure $F = p_{st} \times A$ on the other side. A is the diaphragm area, p_{st} the loading pressure. If the loading pressure changes and consequently the force on the diaphragm, the actuator stem is also moved. The operating direction of the actuator depends on how the springs are arranged in the actuator.

Depending on which fail-safe action is to be used by the control valve when the air supply fails, the springs in the actuator are installed either in the top or in the bottom diaphragm chamber (see Figs. 3 and 4). In both cases, the loading pressure is applied to the other diaphragm chamber.

In the Type 2780-1 Actuator, the loading pressure connections for both fail-safe actions are integrated into the diaphragm case. It is not possible to attach a positioner.

In the Type 2780-2 Actuator, it is possible to directly attach a positioner, since the loading pressure is supplied via inside ducts to the corresponding diaphragm chamber for both fail-safe actions. The loading pressure supply is determined by a switchover plate installed according to the fail-safe action of the actuator and the operating direction of the positioner.

Fail-safe action

The actuator has two different fail-safe actions:

- **Actuator stem extends**, when the air supply fails, the spring force moves the actuator stem to its lower end position (see Figs. 3 and 4 on the left).
- **Actuator stem retracts** when the air supply fails, the spring force moves the actuator stem to its upper end position (see Figs. 3 and 4 on the right).

Technical data

Nominal size	DN	15 to 50 (G½ to G1)	
Effective diaphragm area	cm ²	120	
Maximum supply pressure	bar	4	
Fail-safe action		Reversible	
Rated travel	DN 15 to 25 G½ to G1	mm	6
	DN 32 to 50	mm	12
Bench range	Type 2780-1	bar	0.4 to 1
	Type 2780-2	bar	0.4 to 2 ³⁾
Supply air pressure required	bar	2,4	
Number of springs		3 ¹⁾	
Leakage rate	l_n/h	< 10	
Loading press. connection Type 2780-1		ISO 288/1, G½; NPT½	
Ambient temperature	°C	-10 to 80	
Materials			
Diaphragm case ²⁾		Aluminum GD-ALSi12	
Diaphragm		NBR	
Springs ²⁾		Spring wire C	
External bolts		Chromated steel	
Bushing		CW617N (CuZn40Pb)	
Weight	Type 2780-1	kg	2
	Type 2780-2	kg	3.2

¹⁾ 6 springs for 0.4 to 2 bar bench range and 12 mm rated travel

²⁾ Not painted or surface treated

³⁾ For further bench ranges, see data sheets of control valves

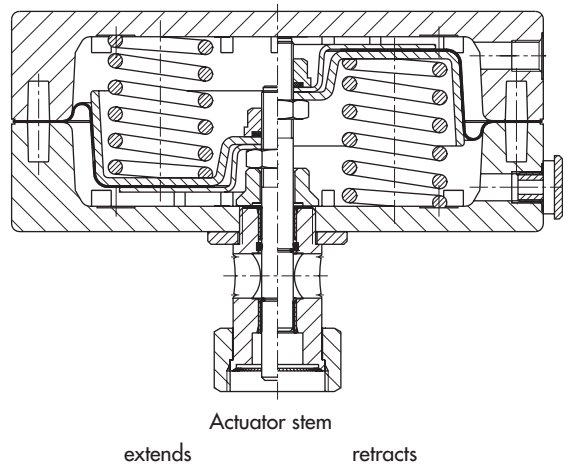

Fig. 3 · Type 2780-1 Actuator (cross section)

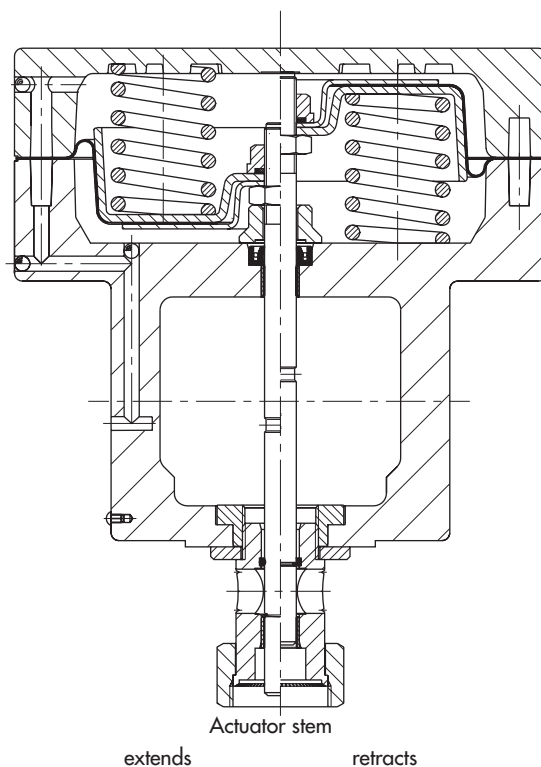

Fig. 4 · Type 2780-2 Actuator (cross section)

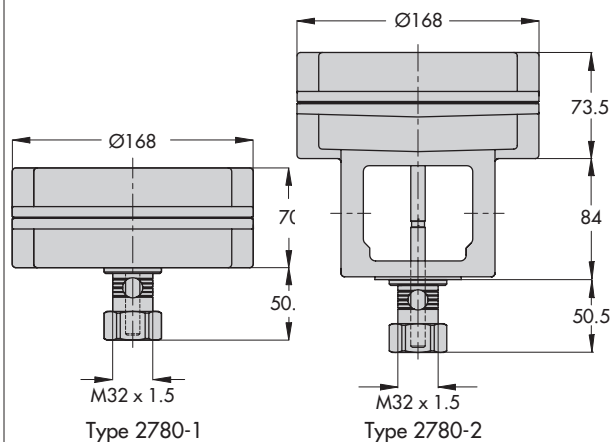

Fig. 5 · Dimensions in mm