

Electric Control Valves with Jet Pump Types 3267/5857, 3267/5824, 3267/5825, 3267/5757, 3267/5724, 3267/5725



Pneumatic Control Valve with Jet Pump Type 3267/2780

Valve with Jet Pump Type 3267 in version with screwed ends

Application

Control circuits in plant engineering and in HVAC systems, especially for district heating networks

Nominal size DN 15 to 32

Nominal pressure PN 16 and 25

Temperatures -10 to +150 °C

In temperature control circuits, the Type 3267 Valves with Jet Pump assume both the function of a valve and that of a circulator pump. They can be optionally combined with electric and pneumatic actuators.

Type 3267 Valve · Inlet with mixing nozzle and diffuser, valve body with screwed ends, version with valve body with screwed ends (male thread)

The **Type 3267** Valve with Jet Pump in version with screwed ends is available with Characteristic 2. Refer to page 6.

Versions

Electric control valves with jet pump		
Type 3267/5857	PN 25	DN 15 to 25
Type 3267/5824 · Fig. 1	PN 25	DN 15 to 32
Type 3267/5825 ¹⁾	PN 25	DN 15 to 32
Electric control valves with jet pump/controllers with electric actuators for DHW heating		
Type 3267/5757	PN 25	DN 15 to 25
Type 3267/5724	PN 25	DN 15 to 32
Type 3267/5725 ¹⁾	PN 25	DN 15 to 32
Electric control valves with jet pump/controllers with electric actuators for heating and cooling applications		
Type 3267/5757-7	PN 25	DN 15 to 25
Type 3267/5725-7 ¹⁾	PN 25	DN 15 to 32
Pneumatic control valves with jet pump		
Type 3267/2780-1	PN 25	DN 15 to 32
Type 3267/2780-2 ²⁾	PN 25	DN 15 to 32

¹⁾ With fail-safe action tested acc. to DIN EN 14597

²⁾ Pneumatic actuator suitable for integrated positioner attachment

Valves with handwheel can be used as jet pumps with handwheel when equipped with a hand-operated actuator (1790-8169).

Also available:

Electric and pneumatic valves with jet pump in **flanged version** (see Data Sheet T 5894 EN).



Fig. 1 · Type 3267/5824

Principle of operation

Fig. 2 schematically illustrates a SAMSON valve with jet pump. It consists of a valve body (1) with jet nozzle (2) and plug (3), mixing nozzle (1.1) and diffuser (1.2). The variable cross-sectional area between the valve plug and jet nozzle determines the jet stream Q_1 .

The jet stream Q_1 is accelerated in the jet nozzle and flows to the mixing nozzle at high speed. The exiting jet draws the partial flow Q_2 with it. In the mixing nozzle, the two flows are mixed together. During the mixing process, the jet stream releases a portion of its kinetic energy to the intake flow. This exchange of energy causes an increase in pressure and, at the same time, a decrease in jet stream velocity. In the downstream diffuser, the velocity is further reduced, and the pressure increases to the output value p_3 .

The turbulence in both the mixing chamber and the mixing nozzle does not only cause the exchange of energy described above, but also causes an exceptionally thorough mixing of the supplied process media. This improved mixing effect guarantees a homogenous condition of the output flow directly downstream of the diffuser.

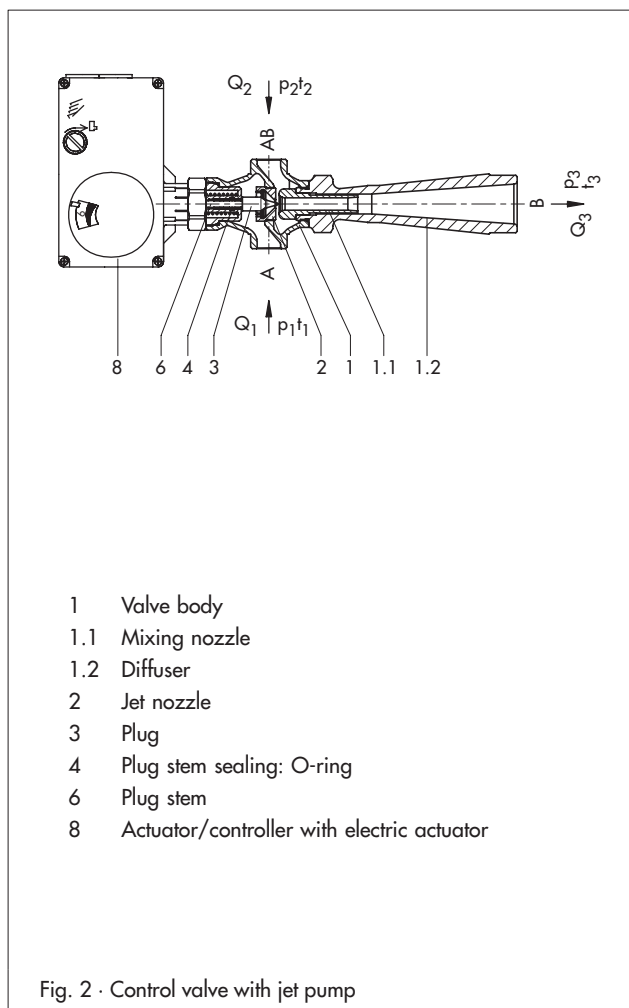

The Type 3267 Valves in version with screwed ends can be combined with Type 5857 and Types 5824/5825 Electric Actuators, with Type 2780 Pneumatic Actuator as well as with Types 5757, 5724 and 5725 Controllers with Electric Actuators for DHW heating and Types 5757-7 and 5725-7 Controllers with Electric Actuators for heating and cooling applications. The nominal sizes of the valves is restricted to DN 25 when combined with Type 5857, Type 5757 or Type 5757-7. The maximum permissible temperature with an intermediate insulating piece is 110 °C (Types 5857, 5757, 5757-7) and 130 °C (Types 5824, 5825, 5724, 5724, 5724-7). The maximum temperature is 150 °C when an intermediate insulating piece is used.

Types 5857, 5824 and 5825 Electric Actuators as well as Types 5757, 5757-7, 5724, 5725 and 5725-7 Controllers with Electric Actuators are designed for a maximum ambient temperature of +50 °C. Type 2780 Pneumatic Actuator is designed for a maximum ambient temperature of +80 °C. It is important to make sure these limit values are not exceeded during operation.

All electric actuators can be controlled by three-point stepping signals, or, with installation of a positioner, continuous-action control signals from 4(0) to 20mA or 0(2) to 10 V. Various electrical accessories can be optionally installed.

The Types 5757, 5757-7, 5724, 5725 and 5725-7 Controllers with Electric Actuators contain a digital controller integrated into the actuator. The controlled variable is measured by a directly connected Pt 1000 sensor. The output signal of the digital controller functions as a three-point stepping signal on the synchronous motor of the actuator and is transferred over the connected gear to the actuator stem and used as the positioning force.

Refer to the data sheets of the actuators for details	
Type 5857	-> Data Sheet T 5857 EN
Type 5824	-> Data Sheet T 5824 EN
Type 5825	-> Data Sheet T 5824 EN
Type 5757	-> Data Sheet T 5757 EN
Type 5724	-> Data Sheet T 5724 EN
Type 5725	-> Data Sheet T 5724 EN
Type 5757-7	-> Data Sheet T 5757-7 EN
Type 5725-7	-> Data Sheet T 5725-7 EN
Type 2780	-> Data Sheet T 5840 EN

Mounting position

The Type 3267 Valve with Jet Pump must be installed with the diffuser in the horizontal position.

Application

Fig. 5 illustrates the simplified functional diagram of a plant equipped with a control valve with jet pump. The network supply flow (Q_1) forms the jet stream of the jet pump by drawing the water in from the return flow (Q_2). The mixing ratio of the flow rates Q_1 and Q_2 as well as the associated temperatures t_1 and t_2 determine the temperature t_3 supplied to the consumer. In this arrangement, the output flow (Q_3) decreases with decreasing heat demand and increases with increasing load.

Fig. 5 illustrates the simplified functional diagram of a plant utilizing an electric circulator pump and a control valve with three-way valve. In this assembly, the output flow Q_3 remains constant over the entire load range.

Advantages on the using control valves with jet pumps:

- Low investment, planning, assembly and start-up costs because the circulator pumps with the shut-off valves are omitted and there is no expense for the associated switching gear; expense of wiring and switch cabinet is also eliminated.
- High operational reliability and minimum maintenance costs since jet pumps are self-operated (depending on equipment).
- Considerable savings in energy since there are no costs for powering the circulator pump. Moreover, the water circulation in the network is lower since the output flow of the jet pump decreases with decreasing heat demand.
- Improved system controllability and significant noise level reduction because there is no circulator pump, and the output flow decreases with reduced load. Thus, improved operating characteristic of downstream valves, e.g. no whistling of radiator valves.

Required pressure and temperature indicators

For plants employing jet pumps, the pressure gauges and thermometers as illustrated in Fig. 5 are required for adjusting and readjusting the system. The pressure gauge/thermometer or equivalent test connections are to be arranged to keep the distance to the connections of the valves (A, B and AB) as small as possible. The pressure gauges for pressures p_1 , p_2 and p_3 are used to determine the differential pressures $\Delta p_H = p_1 - p_2$ and $\Delta p_h = p_3 - p_2$.

The throttle valve (4) serves to adapt pressure and temperature conditions.

Design notes

Similar to the consumer flow temperature t_3 , the output flow Q_3 of jet pump systems is load-dependent, in comparison to heating systems with circulator pumps. To achieve an equal supply and optimum control of flow temperature, the following points must be observed:

- Balance all consumers (radiators)
- Make sure that the radiator is not installed at a lower point of installation than the jet pump
- Limit the horizontal expansion of the plant
- Lead back the return flow of the heating circuit directly to the jet pump first, before mixing it with other heating circuits

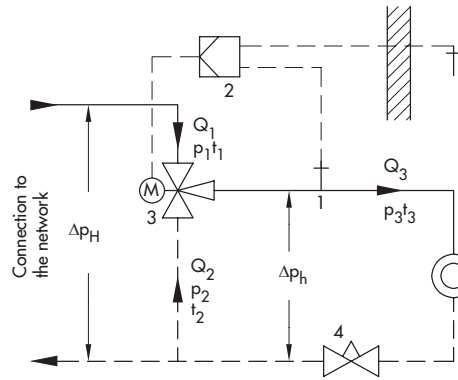

Fig. 3 · Simplified functional diagram with a consumer circuit with jet pump

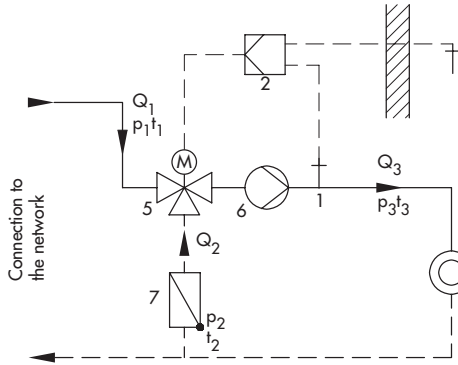

Fig. 4 · Simplified functional diagram with a consumer circuit with circulator pump and three-way valve

Legends for Figs. 3 and 4:

1	Temperature sensor	6	Circulator pump
2	Controller	7	Swing check valve
3	Control valve with jet pump	Q_1	Jet flow (network flow)
4	Balancing valve	Q_2	Intake flow (network return)
5	Control valve with three-way valve	Q_3	Output flow
		V	Consumer

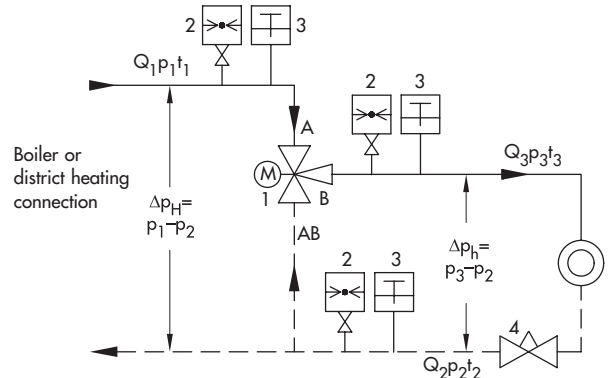

Fig. 5 · Required pressure and temperature measuring equipment for a control valve with jet pump

Legend for Fig. 5:

1	Control valve with jet pump	3	Thermometer
2	Pressure gauge	4	Throttle valve

Jet pump sizing

SAMSON will be responsible for jet pump sizing. For this purpose, please submit the following information:

Thermal output ¹⁾	Q _w in kW
Network flow ¹⁾	p ₁ in bar/ t ₁ in °C
Plant return flow ¹⁾	p ₂ in bar/ t ₂ in °C
Plant flow ¹⁾	p ₃ in bar/ t ₃ in °C
Nominal pressure	PN ...
Body material	Acc. to Table 4 ...

¹⁾ Specify minimum and maximum summertime/wintertime values, a questionnaire available on request

Electric actuator/controller with electric actuator:

Type ..., ... V, ... Hz

Without/with fail-safe action

Additional electrical equipment, such as limit switch, potentiometer, positioner (see data sheets of actuators/controllers with electric actuators)

Pneumatic actuator: Type ...

Actuator stem extends/retracts

Max. supply air pressure ... bar

Table 1.1 · Technical data · Type 3267 Valve with Jet Pump

Nominal size	15	20	25	32
Thread size	G 3/4	G 1	G 1 1/4	G 1 3/4
Nominal pressure	PN 25			
Rated travel	6 mm			
Permissible temperatures	-10 to 150 °C ¹⁾			
Seat/plug sealing	Metal sealing			
Type of characteristic	Linear			
Leakage rate acc. to DIN EN 1349	Class III (≤ 0.01 % of K _{V5} coefficient)			

¹⁾ **Types 3267/5857, 3267/5757, 3267/2780:** Use an intermediate insulating piece for medium temperatures below +5 °C and above +110 °C.

Types 3267/5824, 3267/5825 and Types 3267/5724, 3267/5725: Use an intermediate insulating piece for medium temperatures below +5 °C and above +130 °C (networks with constant medium temperatures).

Table 1.2 · Materials · Type 3267 Valve with Jet Pump

Nominal size	15	20	25	32
Thread size	G 3/4	G 1	G 1 1/4	G 1 3/4
Body	CC491K or CC499K			
Diffuser	CC491K or CC499K			CW509L
Mixing nozzle	CW602N			
Adapter	-			CW617N
Jet nozzle	1.4305			
Plug, plug stem	1.4305			
Guide bushing	CW602N			
Stem sealing	O-ring made of EPDM			

Table 2 · Possible combinations of Type 3267 Valve with Jet Pump/actuator

	Type	Refer to data sheet for details	Nominal size DN			
			15	20	25	32
Electric actuators	5857	T 5857 EN	•	•	•	–
	5824-10	T 5824 EN	•	•	•	•
	5824-13		•	•	•	•
	5825-10		•	•	•	•
	5825-13		•	•	•	•
Controllers with electric actuators for DHW heating	5757	T 5757 EN	•	•	•	–
	5724-10	T 5724 EN	•	•	•	•
	5724-13		•	•	•	•
	5725-10		•	•	•	•
	5725-13		•	•	•	•
Controller with electric actuator for heating/cooling applications	5757-7	T 5757-7 EN	•	•	•	–
	5725-710	T 5725-7 EN	•	•	•	•
Pneumatic actuators	2780-1	T 5840 EN	•	•	•	•
	2780-2		•	•	•	•

Table 3 · Permissible differential pressures · All pressures stated in bar (gauge)

The permissible differential pressures stated are nominal values. They are limited by the pressure-temperature diagram and the pressure ratings. In the closed position, the leakage rate indicated in Table 1.1 is not exceeded.

Pneumatic control valves can only be used without a positioner in the 0.2 to 1.0 bar signal pressure range. For all other cases, a positioner is required.

Type	Electric actuators/Controllers with electric actuators					Signal pressure	Pneumatic actuators	
	5857 5757 5757-7	5824-10 5724-10	5824-13 5724-13	5825-10 5725-10 5725-710	5825-13 5725-13		2780-1	2780-2
Nominal thrust	0.3 kN	0.7 kN	0.7 kN	0.5 kN	0.5 kN		0.4 to 1 bar	0.4 to 2 bar
K_{VS}	Δp_H						Δp_H	
0.32	18	25	25	25	25		25	
0.5	9	23	23	16	16		15	
0.8	9	23	23	16	16		15	
1.25	4	10.5	10.5	7	7		7	
1.0	4	10.5	10.5	7	7		7	
1.6	4	10.5	10.5	7	7		7	
2.0	–	5.5	5.5	3.5	3.5		3.5	
3.2	–	5.5	5.5	3.5	3.5		3.5	

Table 4.1 · Dimensions and weights · Type 3267 Valve with Jet Pump

Nominal size A, B, AB	DN	15	20	25	32
Thread size A, B, AB		G 3/4	G 1	G 1 1/4	G 1 3/4
Overall length L1	mm	65	70	75	100
Length L2	mm	100	140	180	230
Height H2	mm	45	45	45	95
Height H3	mm	175	175	175	230
Weight without actuator	Approx. kg	0.8	1.2	2.0	6.0

Table 4.2 · Dimensions and weights · Actuators/controllers with electric actuator

Actuators/ controllers with electric actuator	Type	5857 5757	5824 5724	5825 5725	2780
Effective area	cm ²	-			120
Loading pressure connection		-			G 1/8
Weight	Approx. kg	-	-	1.5	2
With handwheel	Approx. kg	0.7	1.3	-	-

Table 5 · Jet pump versions

 Nominal size, K_{VS} coefficients, body materials

DN	Characteristic 2: K _{vs}	Travel	PN/material
15	0.32 · 0.5	6 mm	PN 25/CC491K PN 25/CC499K
20	0.8 · 1.25		
25	1.0 · 1.6		
32	2.0 · 3.2		

Specifications subject to change without notice.

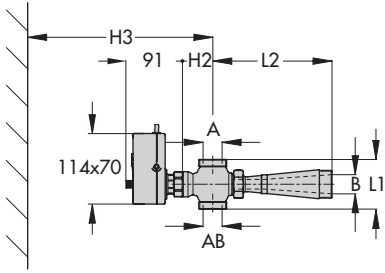

Type 3267/5857: DN 15 to 25
 Type 3267/5757: DN 15 to 25

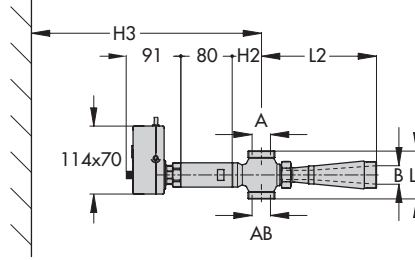

Version with intermediate insulating piece for temperatures below +5 °C and above +110 °C

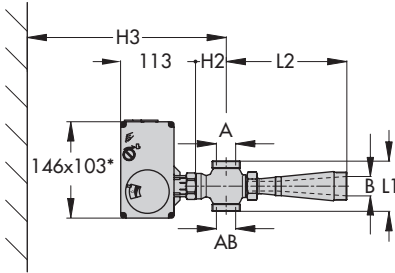

Type 3267/5824: DN 15 to 32
 Type 3267/5825: DN 15 to 32
 Type 3267/5724: DN 15 to 32
 Type 3267/5725: DN 15 to 32

* Dimensions for Types 5824-13, 5825-13, 5724-13 and 5725-13: 146 x 136

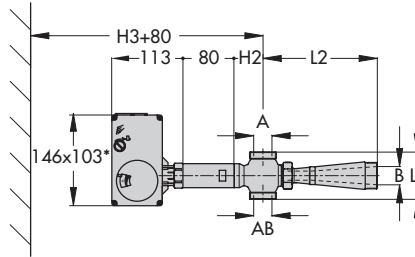

Version with intermediate insulating piece for temperatures below +5 °C and above +130 °C

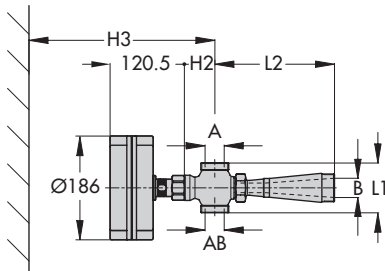

Type 3267/2780-1: DN 15 to 32

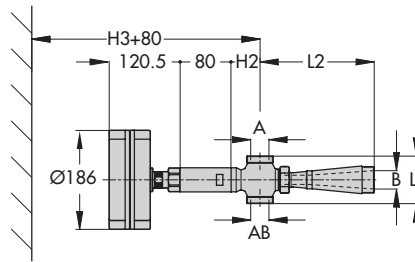

Version with intermediate insulating piece for temperatures up to 150 °C

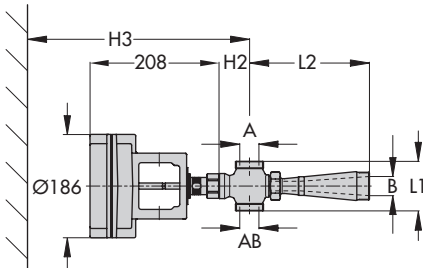

Type 3267/2780-2: DN 15 to 32

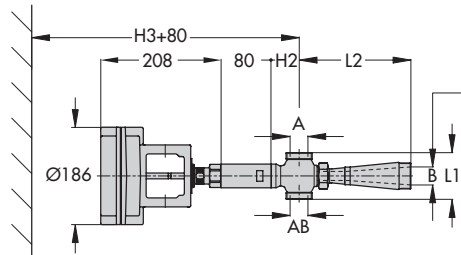

Version with intermediate insulating piece for temperatures up to 150 °C



SAMSON AG · MESS- UND REGELTECHNIK
Weismüllerstraße 3 · 60314 Frankfurt am Main · Germany
Phone: +49 69 4009-0 · Fax: +49 69 4009-1507
Internet: <http://www.samson.de>

T 5895 EN

2010-04