

## Electropneumatic Converters for Direct Current Signals

### i/p Converter Type 6111

#### Application

Instruments used to convert direct current input signals into pneumatic output signals for measuring and control tasks. Especially suitable as intermediate element between electric measuring devices and pneumatic controllers (or between electric control devices and pneumatic control valves).



These converters are designed for use in all kinds of industrial applications, especially in the field of process engineering.

The converters accept a load-independent 4 to 20 mA or 0 to 20 mA direct current input signal which they convert into a pneumatic output signal.

Wide output pressure ranges can be selected for the Type 6111 i/p Converter by installing various converter modules (see Technical data). The maximum output pressure that can be achieved is 8 bar.

#### Special features

- Wide selection of measuring ranges
- High output pressures up to 8 bar
- Easy replacement of i/p module
- Zero reset at specific mA-value when switch-off electronic function is activated (function can be activated as required)
- Operation possible without an upstream pressure regulator
- Version designed as rail-mounting unit with plastic housing or as field unit for offshore applications in a stainless steel enclosure
- Supply air manifold for rail-mounting units available as accessories for 3, 4, 5 and 6 converter units (Fig. 4)

#### Versions

- **Type 6111 designed as rail-mounting unit** (Fig. 1) · Suitable for snap-on mounting on a top-hat rail
- **Type 6111 designed as field unit** for offshore applications (Fig. 2) · Mounted using a bracket

#### Special versions (on request)

- Input signal 0 (2) to 10 V with Type 6151 Module
- Electric connection with an angle connector according to DIN EN 175301-803 A
- AS-Interface connection over Type 6150 Module

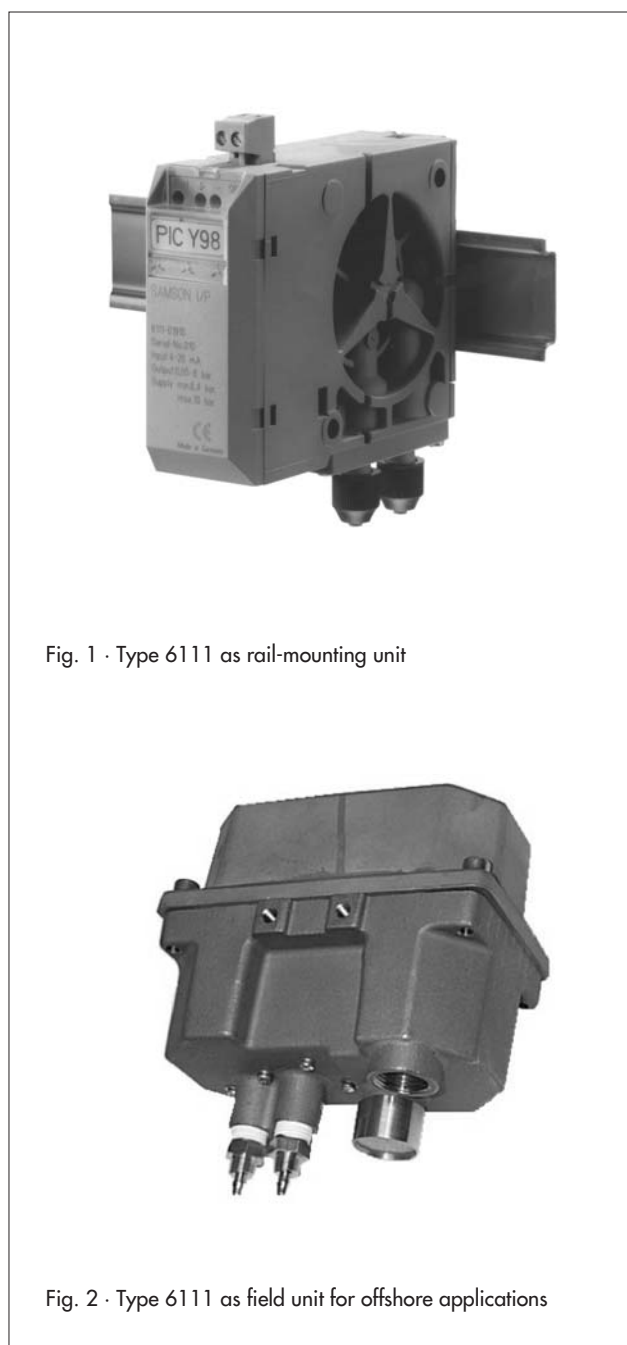

Fig. 1 · Type 6111 as rail-mounting unit

Fig. 2 · Type 6111 as field unit for offshore applications

### Principle of operation (Fig. 3)

Electropneumatic converters essentially consist of an i/p converter module operating according to the force-balance principle and a connected volume booster.

When operated, the supplied direct current (4) flows through the plunger coil (2) in the field of the permanent magnet (3). At the balance beam (1), the force of the plunger coil, which is proportional to the current, is balanced against the force of the back-pressure. The back-pressure is produced on the flapper plate (6) by the air jet leaving the nozzle (7).

The nozzle is supplied with air from the pneumatic output (36). At an input signal of 0 mA, an output pressure of approximately 50 to 80 mbar already exists due to the offset spring.

The supply air (9) flows in the lower diaphragm chamber, and a certain amount flows to the output. When the current increases, the flapper moves closer to the nozzle. The force of the resulting back-pressure pushes both the diaphragm (5) and sleeve (8) downwards, allowing additional air to enter the chamber. The passing air volume increases until the forces on the diaphragm obtain a state of equilibrium. When the current decreases, this action is reversed. The back-pressure created by the nozzle and flapper decreases, and the diaphragm is pressed upwards. In this process, it releases the sleeve, if applicable, and opens the vent (11) until the forces on the diaphragm are balanced again.

Devices with an input signal range from 4 to 20 mA have a slide switch which activates the switch-off electronic function. This function causes the pneumatic output to be vented up to approx. 100 mbar when the input signal falls below  $4.08 \text{ mA} \pm$  tolerance. In this way, the tight shut-off function of a valve can be guaranteed.

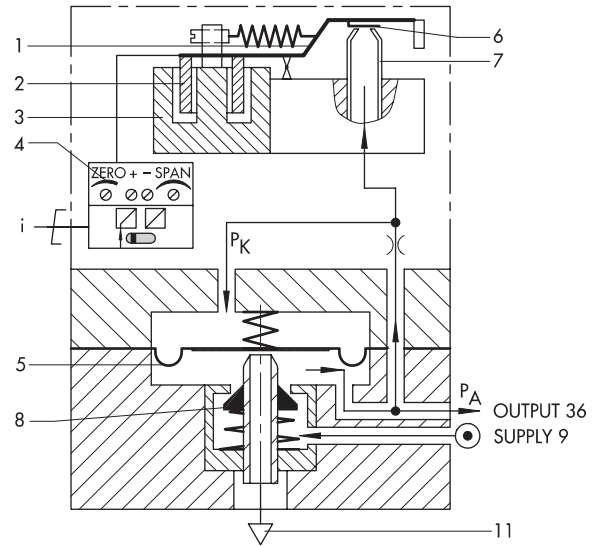

- |   |                  |    |            |
|---|------------------|----|------------|
| 1 | Balance beam     | 7  | Nozzle     |
| 2 | Plunger coil     | 8  | Sleeve     |
| 3 | Permanent magnet | 9  | Supply air |
| 4 | Input            | 11 | Vent       |
| 5 | Diaphragm        | 36 | Output     |
| 6 | Flapper plate    |    |            |

Fig. 3 · Functional diagram



Fig. 4 · Supply air manifold for Type 6111

## Technical data

Converter	Type 6111	Rail-mounting unit	Field unit
Input		4 to 20 mA (0 to 20 mA on request); For split-range: 4 to 12 mA or 12 to 20 mA; Other signals on request	
Load	Standard Explosion-protected version Device without switch-off electronics	≤ 6 V (corresponding to 300 Ω at 20 mA) 7 V (corresponding to 350 Ω at 20 mA) ≤ 4 V (corresponding to 200 Ω at 20 mA)	
Explosion protection		⊕II 2 G EEx ia IIC T6	⊕II 3 G EEx nA II T6
Output	With Type 6112 i/p Module	0.2 to 1 bar (3 to 15 psi) (standard range) 0.4 to 2 bar (6 to 30 psi) (standard range) Special ranges adjustable at the factory to meet customer specifications: Initial value; Span Δp	
	Module A	0.1 to 0.4 bar;	0.75 to 1.0 bar
	Module B	0.1 to 0.4 bar;	1.0 to 1.35 bar
	Module C	0.1 to 0.4 bar;	1.35 to 1.81 bar
	Module D	0.1 to 0.8 bar;	1.81 to 2.44 bar
	Module E	0.1 to 0.8 bar;	2.44 to 3.28 bar
	Module F	0.1 to 0.8 bar;	3.28 to 4.42 bar
	Module G	0.1 to 1.2 bar;	4.42 to 5.94 bar;
	Module H	0.1 to 1.2 bar;	5.94 to 8.0 bar <sup>1)</sup>
Maximum air output capacity		2.0 m <sup>3</sup> /h at an output of 0.6 bar (0.2 to 1.0 bar) 2.5 m <sup>3</sup> /h at an output of 1.2 bar (0.4 to 2.0 bar) 8.5 m <sup>3</sup> /h at an output of 5.0 bar (0.1 to 8.0 bar)	
Supply air		At least 0.4 bar above the upper signal pressure value, maximum 10 bar without upstream pressure regulator	
Air consumption		0.08 m <sub>n</sub> <sup>3</sup> /h at 1.4 bar 0.10 m <sub>n</sub> <sup>3</sup> /h at 2.4 bar Maximum 0.26 m <sub>n</sub> <sup>3</sup> /h at 10 bar	
Performance <sup>2)</sup>		Characteristic: Output linear to the input	
Hysteresis		≤ 0.3 % of the final value	
Deviation from terminal-based conformity		≤ 1 % of the final value	
Influence in % of the final value		Supply air: 0.1 %/0.1 bar	
		Alternating load, supply air failure, interruption of input current: < 0.3 %	
		Ambient temperature: Lower range value < 0.03 %/°C, measuring span < 0.03 %/°C	
Dynamic performance		With an output between 0.2 and 1 bar	
Limiting frequency		5.3 Hz	
Phase shift		-130°	
Variable position		Maximum 3.5 % depending on how device is mounted, e.g. ±1 % in horizontal position	
<b>Ambient conditions, degree of protection, weight</b>			
Ambient temperature		-20 to 70 °C	
Storage temperature		-40 to 70 °C	
Degree of protection		IP 20	IP 65
Weight	approx.	0.35 kg	1.9 kg
<b>Materials</b>			
Housing		Glass fiber reinforced polyamide	Stainless steel 1.4581

<sup>1)</sup> The maximum possible output pressure is 8 bar

<sup>2)</sup> Measured according to IEC 770

### List of issued explosion protection certificates

Type of approval	Certificate number	Date	Comments
<b>Type 6111-1:</b> EC Type Examination Certificate	PTB 01 ATEX 2174	2001-11-26	⊕II 2 G EEx ia IIC T6
<b>Type 6111-8:</b> Statement of Conformity	PTB 02 ATEX 2013 X	2001-11-26	⊕II 3 G EEx nA II T6

The certificates are contained in the mounting and operating instructions or can be requested.

## Electrical connection

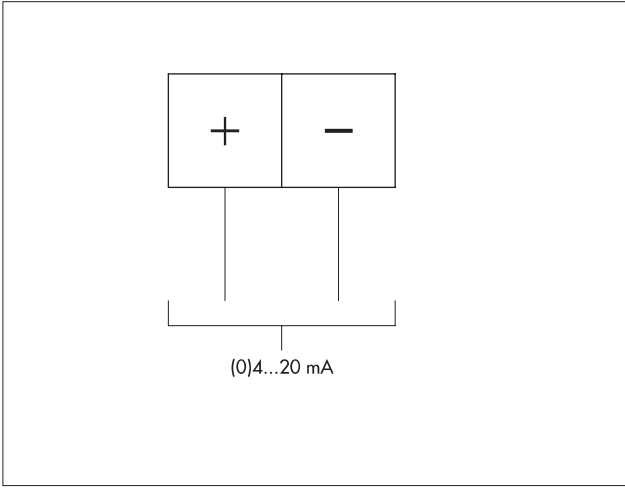

## Installation

- **Rail-mounting unit** for mounting on a top hat rail acc. to DIN EN 50022, 35 mm wide
  - Wall mounting possible, using holes with  $\varnothing 5.5$  mm
  - Air connections (supply air and output): hose connection suitable for hose 4 x 1 (outer  $\varnothing 6$  mm) as standard; also available as ports with  $\frac{1}{8}$  NPT, G  $\frac{1}{8}$  or M5 female thread
  - Electrical connections: Terminals for 0.5 to 2.5 mm<sup>2</sup> wires  
**Note:** On using a plug-on terminal, the connections marked "+" and "-" at the front of the converter are to be ignored.
- **Field unit for offshore applications** mounted using a bracket
  - Bracket (stainless steel), order no: 1400-7432
  - Pneumatic connections:  $\frac{1}{4}$  NPT
  - Electrical connection: M20 x 1.5

**Article code**

Converter		Type 6111-x															
<b>Explosion protection</b>	Without	0		x	x	x	x	x	x	x	x	x	x	x	x	x	x
	⊕ II 2G EEx ia IIC T6 (ATEX)	1	0														
	⊕ II 3G EEx nA II T6 (ATEX)	8	1														
<b>Housing</b>	For rail mounting, 35 mm top-hat rail (DIN EN 50022)	0															
	Field unit made of stainless steel 1.4581	1															
<b>i/p module</b>	Type 6109			1													
	Type 6112			2													
<b>Input</b>	4 to 20 mA with switch-off electronic function					0	1										
	0 to 20 mA without switch-off electronic function <sup>1)</sup>			2	0	2											
	4 to 12 mA with switch-off electronic function			2	0	3											
	12 to 20 mA with switch-off electronic function			2	0	4											
<b>Booster</b>	I (output above 0.1 bar/3 psi)						1										
	II (output above 0 bar/0 psi) <sup>2)</sup>			2		2											
<b>Output</b>	0.2 to 1.0 bar						1	0	1								
	3 to 15 psi						1	0	2								
	0.4 to 2.0 bar			2			1	0	3								
	6 to 30 psi			2			1	0	4								
Special ranges <sup>3)</sup>	Initial value	Span Δp															
	0.1 to 0.4 bar	0.75 to 1.00 bar			2		1	1									
	0.1 to 0.4 bar	1.00 to 1.35 bar			2		1	2									
	0.1 to 0.4 bar	1.35 to 1.81 bar			2		1	3									
	0.1 to 0.8 bar	1.81 to 2.44 bar			2		1	4									
	0.1 to 0.8 bar	2.44 to 3.28 bar			2		1	5									
	0.1 to 0.8 bar	3.28 to 4.42 bar			2		1	6									
	0.1 to 1.2 bar	4.42 to 5.94 bar			2		1	7									
	0.1 to 1.2 bar	5.94 to 8.00 bar			2		1	8									
	<b>Direction of action</b>	Increasing/increasing								1							
Increasing/decreasing				2					2								
<b>Pneumatic connection</b>	Hose connection M10 x 1 for hose 4 x 1			0												0	
	1/8"-27 NPT female thread			0												1	
	ISO-228/1-G 1/8" female thread			0												2	
	M5 female thread			0												3	
	1/4"-18 NPT			1												4	
<b>Electrical connection</b>	Terminals for 0.5 to 2.5 mm <sup>2</sup> wires			0													1
	Angle connector acc. to DIN EN 175301-803			0													2
	M20 x 1.5			1													3
<b>Degree of protection</b>	IP 20			0													1
	IP 65			1													2
<b>Temperature range</b>	Tmin ≥ -20 °C																0
<b>Special version</b>	Without																0 0 0

<sup>1)</sup> Without switch-off electronic function and without potentiometer for zero and span adjustment

<sup>2)</sup> A stable compressed air network is necessary for the version with booster II.  
The specifications concerning supply air pressure need to be strictly observed (always exactly 0.4 bar greater than the max. output signal).

<sup>3)</sup> Specify setting range, e.g. set to 0.1 to 4 bar;  
Output pressure max. 8 bar, supply air max. 10 bar

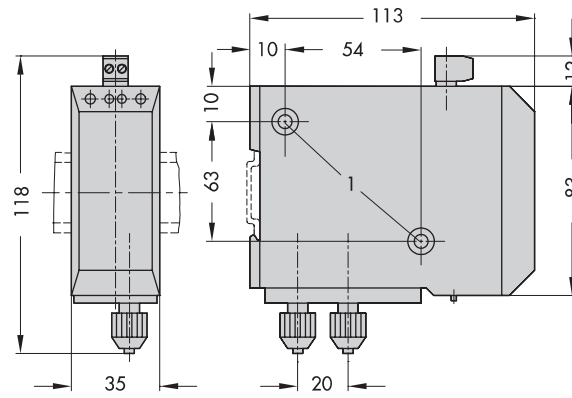

**Type 6111 designed as rail-mounting unit**

1 Holes for wall mounting

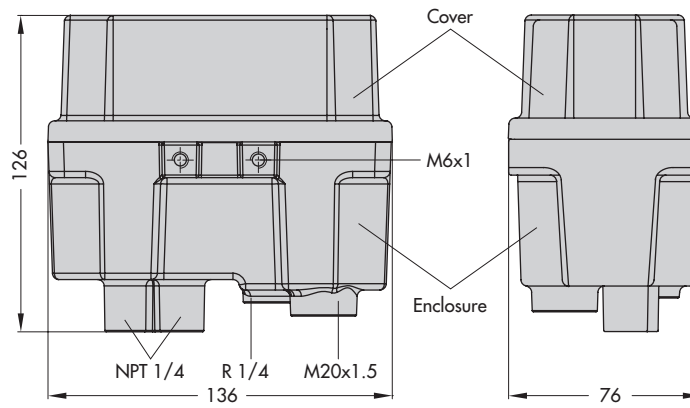

**Type 6111 designed as field unit**

Specifications subject to change without notice.